



Flushmount Sectional Overhead Door

Structural fixing detail for door openings

Please follow diagrams for correct installation of doors up to:
2450mm high *

* Width may vary and is dependent on the type of cladding chosen, consult with your B&D representative prior to installation.

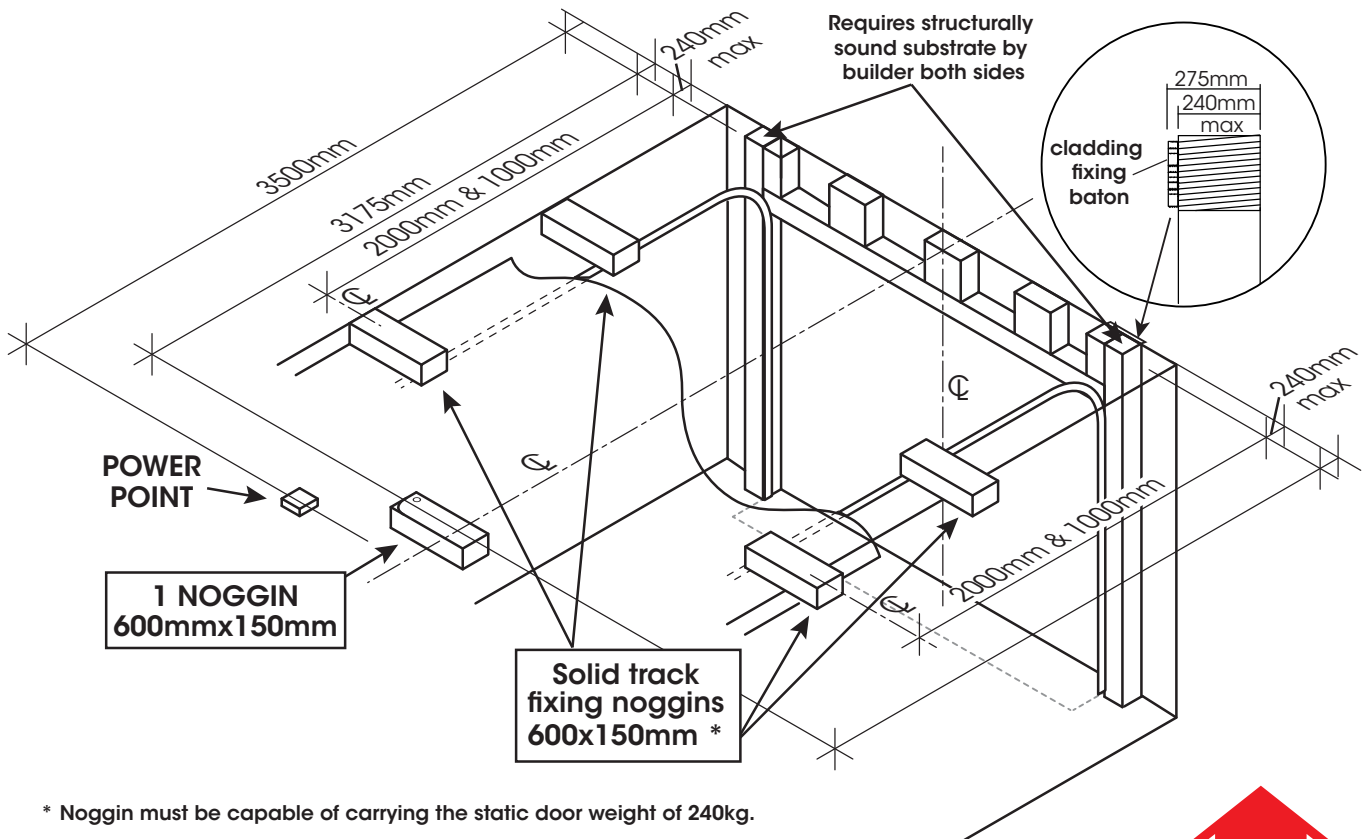
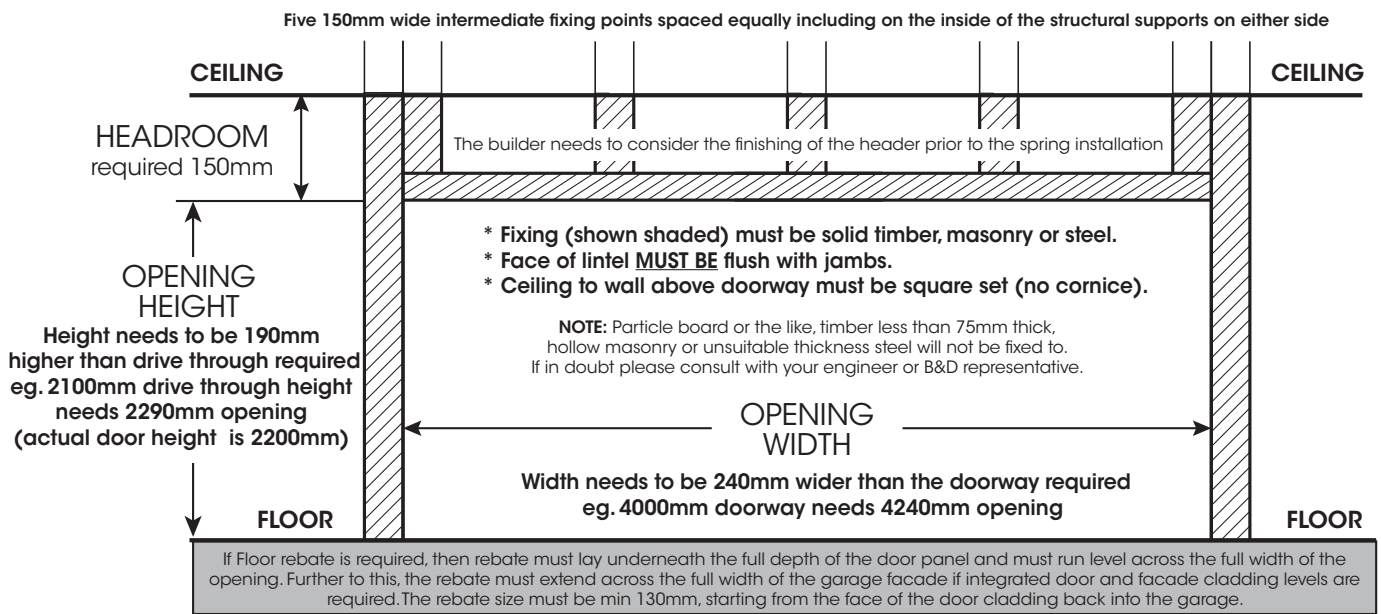

Please follow diagrams for correct installation of doors up to:
2445mm - 3050mm high *

* Width may vary and is dependent on the type of cladding chosen, consult with your B&D representative prior to installation.

