



Roll-A-Shutter®

ESY Shutter™, 8, 10 & 12/100 Series

Structural fixing detail for shutter openings

Please follow diagram for correct installation of shutters up to:
6800mm high x 7000mm wide

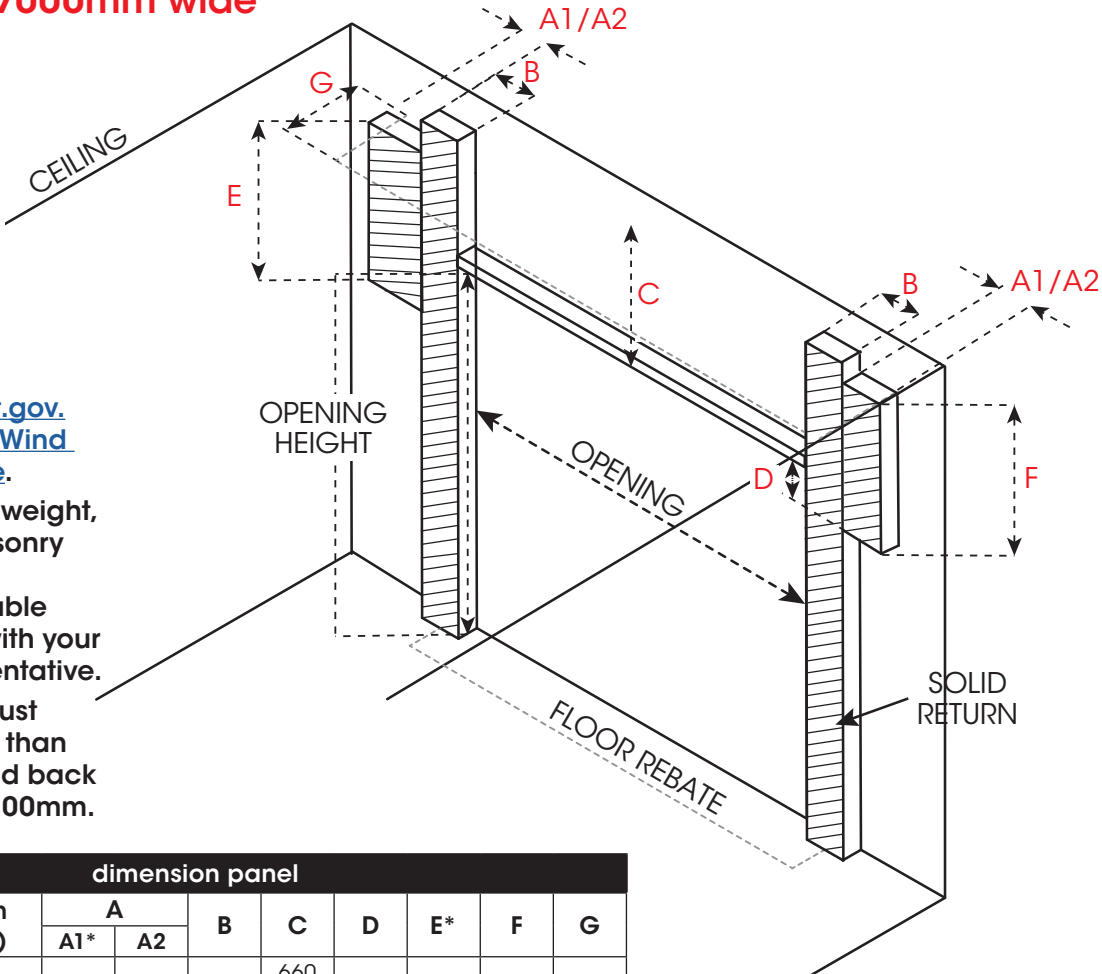

- Fixing (shown shaded) steel.
- The structure substrate **MUST** conform to the high wind requirements. Refer to bac.nt.gov.au for DTCM manual or [High Wind drawings on the B&D Website](#).
- Depending on door size and weight, steel will be required. All masonry must be solid bricks or core filled. Steel must be of a suitable thickness. If unsure consult with your engineer or your B&D representative.
- If floor rebate is required it must extend at least 100mm more than the opening on each side and back from the fixing face at least 100mm.

dimension panel										
installation	height (mm)	width (mm)	A		B	C	D	E*	F	G
			A1*	A2						
ESY Shutter	up to 2000	up to 4300	120	80	100	660	350	700	700	700
	2001 - 3000					696				
	3001 - 4000					710				
	4001 - 4600					754				
Spring Balanced	up to 3000	up to 7000	200	150	100	390	100	700	700	590
	3001 - 3900					440				640
	3901 - 5100					460				660
	5101 - 6500					476				675
	6501 - 6800					492				692
Springless - Direct Drive	up to 3000	up to 4200	200	N/A	100	696	100	700	700	1040
	3001 - 3900	up to 6000				710				
	3901 - 5100	up to 5700				754				
	5101 - 6000	up to 6000				790				
Springless - Direct Lift Chain Drive	up to 3000	up to 7000	290	N/A	100	696	200	1000	600	744
	3001 - 3900					710				765
	3901 - 5100					760				831
	5101 - 6500					790				885
	6501 - 6800					830				915

*A1 recommended sideroom based on the opener being installed.
 A2 recommended sideroom without opener.
 *E recommended sideroom length based on the opener being installed



Please follow diagram for correct installation of shutters up to:
10000mm high x 12000mm wide

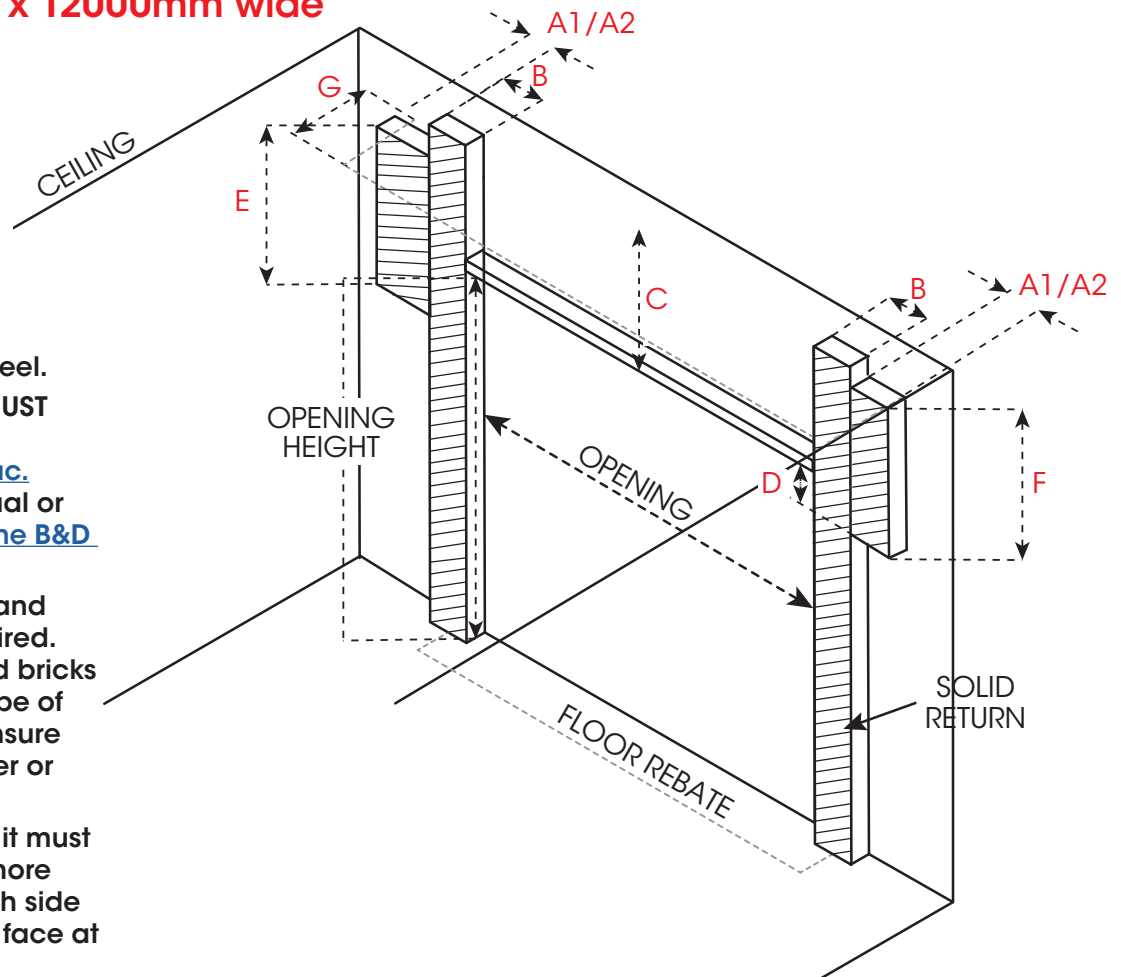

- Fixing (shown shaded) steel.
- The structure substrate **MUST** conform to the high wind requirements. Refer to bac.nt.gov.au for DTCM manual or [High Wind drawings on the B&D Website](#).
- Depending on door size and weight, steel will be required. All masonry must be solid bricks or core filled. Steel must be of a suitable thickness. If unsure consult with your engineer or your B&D representative.
- If floor rebate is required it must extend at least 100mm more than the opening on each side and back from the fixing face at least 100mm.

dimension panel										
installation	height (mm)	width (mm)	A		B	C	D	E*	F	G
			A1*	A2						
Spring Balanced	up to 2400	7000 - 10000	200	150	100	390	100	700	700	590
	2401 - 3000	7000 - 9000				440				640
	3001 - 3900	7000 - 8500				460				660
	3901 - 5100	7000 - 8000				476				676
	5101 - 6500	7000 - 7500				492				692
Springless - Direct Drive	up to 3000	7000 - 9000	200	N/A	100	700	100	700	700	1040
	3001 - 3900	7000 - 8500				768				
	3901 - 5100	7000 - 8500				820				
	5101 - 6500	7000 - 7500				850				
	6501 - 6800	7000				860				
Springless - Direct Lift Chain Drive	up to 3000	7000 - 12000	290	N/A	100	720	200	1000	600	780
	3001 - 4200					768				852
	4201 - 5400					820				930
	5401 - 6500					850				975
	6501 - 7500					860				990
	7501 - 9000					890				1010
	9501 - 10000					910				1040

*A1 recommended sideroom based on the opener being installed.

A2 recommended sideroom without opener.

*E recommended sideroom length based on the opener being installed

