

**b&d**

# Roll-A-Shutter®

Direct Lift 6, 8, 10 & 12/100 Series  
installation instructions

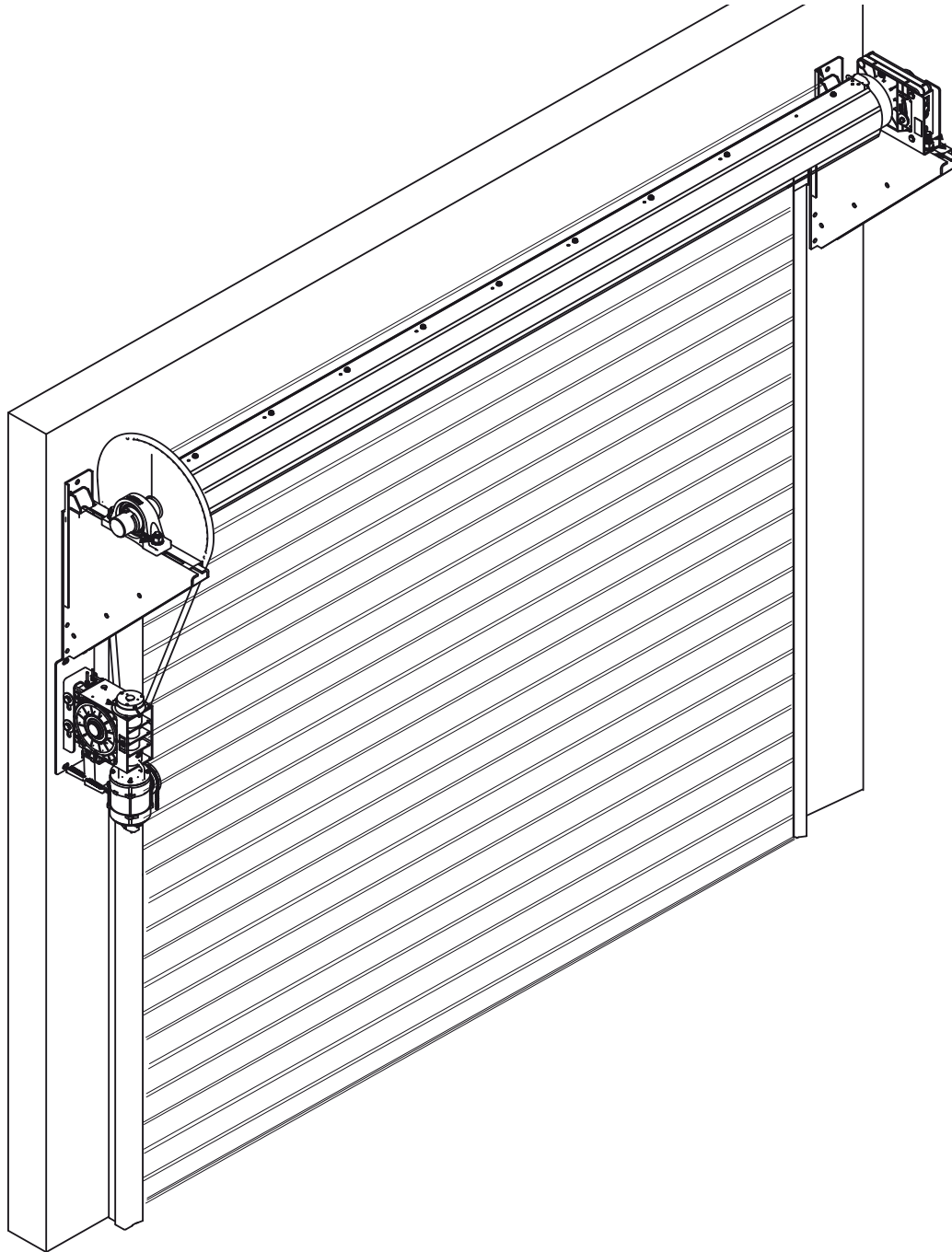

These instructions are intended for professional garage door installers. All references are taken from inside looking out.

DOC# 165031\_01  
RELEASED: 28/11/23

[www.bnd.com.au](http://www.bnd.com.au)

**b&d**

## Contents

<b>1.0 before you start</b>	<b>3</b>
1.1 installation safety warnings	3
1.2 substrate fastener recommendations	4
1.3 preparation	5
1.4 before installation	5
1.4.1 requirements	5
1.4.2 measurements	5
1.4.3 measurements direct lift / direct drive	6
1.4.4 measurements direct lift / chain drive	7
1.5 tools and equipment	8
1.6 specifications	8
1.7 mounting weights	9
<b>2.0 installation</b>	<b>10</b>
2.1 install first bracket	10
2.2 install second bracket	10
2.2 position the drum assembly on brackets	11
2.2.1 direct drive position	11
2.2.2 chain drive position	12
2.3 preparing and fitting the curtain	13
2.4 fitting the curtain to the drum	13
2.5 install the guides	14
<b>3.0 after installation care</b>	<b>16</b>

# 1.0 before you start

## 1.1 installation safety warnings

This B&D Roll-A-Shutter is designed and tested to provide security, attractive appearance and smooth, low effort operation provided it is installed and operated in strict accordance with the following safety warnings. Failure to comply with the following instructions may result in death, serious personal injury or property damage.

**NOTE:** No guarantee will be given or responsibility accepted by the manufacturers if the door is not installed as instructed.



### WARNING!

Crush injury from unsecured door

Tension Springs

- Place a 2 metre exclusion zone around area under the garage opening while installing shutter. If sufficient area is not available DO NOT install shutter.
- Do not move under a shutter while it is on the lifting device.
- Follow the installation instructions.
- Fit lifting device snugly under shutter before lifting.
- Ensure lifting device is on flat ground.
- Ensure the drum is immediately fastened to the bracket with bearings provided.
- Ensure no-one walks under a shutter sitting on brackets.
- Ensure shutter is correctly secured at all times when making adjustments.
- Ensure the correct length pipe wrench is utilised.
- Ensure that pipe wrench is fitted correctly to the axle and if it is gripped onto the axle do not underestimate the tension in the spring when undoing the clamps.
- Ensure correct bolts are tightened or loosened to ensure there is no release or controlled release of energy from the spring through the pipe wrench.
- Keep head clear of the pipe wrench at all times.



### ELECTROCUTION!

- Check risk assessment for any highlighted electrical power concerns.
- Ensure power source is isolated prior to commencement of job.
- Turn off electricity to site when necessary.
- Wear rubber soled footwear.



### LACERATION:

- Wear appropriate PPE (Dyneema cut off gloves) and keep hands well clear of pinch points.
- Follow instructions explicitly, particularly for the installation of some parts of the doors, as the unrolled cut out edges presents a very sharp edge.



### CAUTION:

Muscular strain

Fall from boom lift

Hand Tools

Entanglement

- Practice correct lifting techniques when required to lift the door.
- Use mechanical aids such as lifting devices, forklift and cranes where possible.
- Avoid twisting.
- Use correct technique of knotted rope installation aids.
- Ensure boom lift is the correct type for job.
- Ensure boom lift is on flat firm ground that will take the weight without the structure sinking.
- Ensure user is connected by harness while on boom lift.
- Do not work outside of the boom lift cage.
- Wear appropriate PPE and utilise operators manual of all tools.
- Use appropriate noise/hearing protection in the form of ear plugs or ear muffs.
- Ensure appropriate fire protection available and housekeeping to ensure that flammable liquids or materials are removed from the area of work.
- Keep hands and loose clothing clear of moving shutte and guides at all times.
- With the use of a mechanical aid this product requires a two person lift to raise onto the brackets. Use proper techniques and equipment to lift the shutter from the trailer and up onto brackets.



### TWO PERSON LIFT:

1.2 substrate fastener recommendations

**WARNING!** The installer must select and use fasteners appropriate to the material into which they are being fixed.

**WARNING!** Refer to the weight label on the packaging or the B&D Product Guide to ensure the selected fastener is appropriate.

important notes

- a) For installation to materials not covered in the chart, the installer should seek expert advice from a qualified builder.
- b) Minimum length of fastener does not exclude use of longer lengths. Decision must be made by fitter to ensure adequate strength.

material	fastener type(s)	diameter or type		length of fastener (see note)	BKT	GUIDE
New Hollow Brick (core filled)	HRD-VGK or HGK-VGS (Hex Head) Frame Anchors	10mm	x	60mm	•	•
	Screw masonry (flange hex head)	8mm	x	75mm	•	•
	Screw masonry (flange hex head)	10mm	x	75mm	•	•
New Solid Concrete	Coach Bolts (Hex Lag Screw) - combined with wall plugs	5/16"	x	1½"		•
		3/8"	x	2"	•	•
	Macplugs (wall plugs) to suit above	5/16"	x	50mm		•
		3/8"	x	60mm	•	•
	HLC Sleeve Anchors (Dyna Bolts)	12mm	x	55mm	•	
Screw masonry (flange hex head)	8mm	x	75mm	•	•	
	10mm	x	75mm	•	•	
Steel Framing e.g. BHP Framing (with rear access)	Hex Head Bolt Zinc Plated, Hexagon Nuts Zinc Plated, Washers Zinc Plated	5/16"	x	1"		•
		3/8"	x	1"	•	•
		10mm	x	25mm	•	•
		12mm	x	25mm	•	
Heavy Gauge Steel	Hex Head Tek	14-20	x	22mm	•	•

- c) Recommendations for old materials or materials not in good condition are not included. If in doubt about the strength of the material seek specialist advice.
- d) Fasteners for brackets in masonry should be at least 5/16" x 2.5" long or metric equivalent.

STEEL CONSTRUCTION

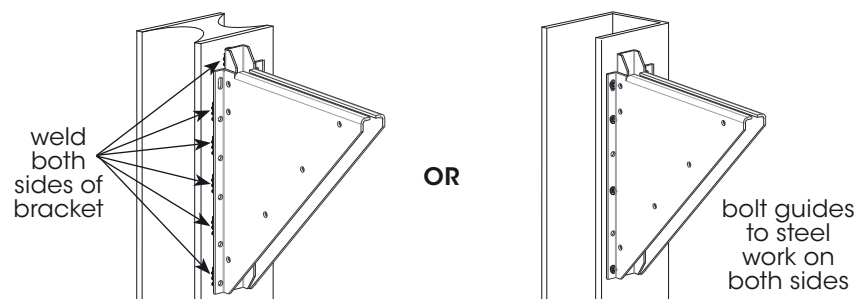

SECURE GUIDE

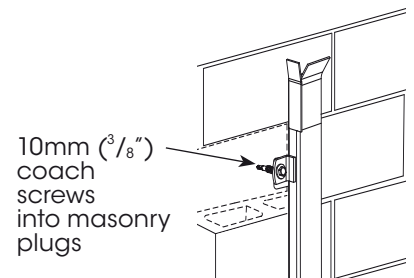

MASONRY BLOCK CONSTRUCTION

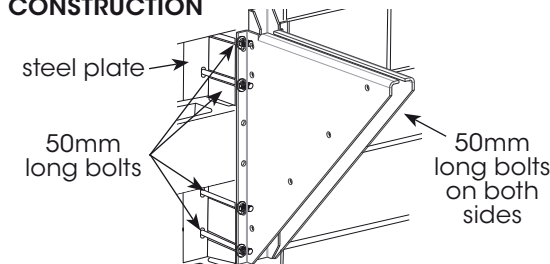

**WARNING!** Masonry blockwork should be properly filled and reinforced if brackets are to be mounted directly to blockwork with masonry anchors. Where the blockwork is not solidly filled but structurally sound, long bolts should be passed through the blockwork using suitable steel plates under bolt heads. Special consideration should be given to brick type and construction of wall, to ensure satisfactory fixing e.g. welding detail if fixed to steel.

Fig: 1.2.1



### 1.3 preparation



**WARNING!** If you need to remove an old shutter prior to installing a B&D shutter ensure to:

- Roll the curtain up and secure curtain around the middle.
- Use correct lifting techniques and machinery.
- Fit machinery snugly under shutter before loosening the brackets or locating U bolts.
- Slowly undo bolts to release the spring tension and the shutter from the brackets.
- Slowly lift the shutter from the brackets keeping it balanced as it is lowered to the ground.

### 1.4 before installation

#### 1.4.1 requirements

**mounting** - The shutter is designed to be mounted behind the opening.

**obstructions** - Ensure that the surface where the shutter will be fitted is flush and smooth, and the area behind the opening is free from any protrusions.

**structural suitability** - Ensure the opening is strong enough to support the shutter. If unsure, consult a builder.

**level and plumb** - The shutter must be installed in an absolutely level position, if opening is not level and square, appearance and/or sideroom requirements will be affected. The floor should be level or recessed across the opening to avoid gaps.

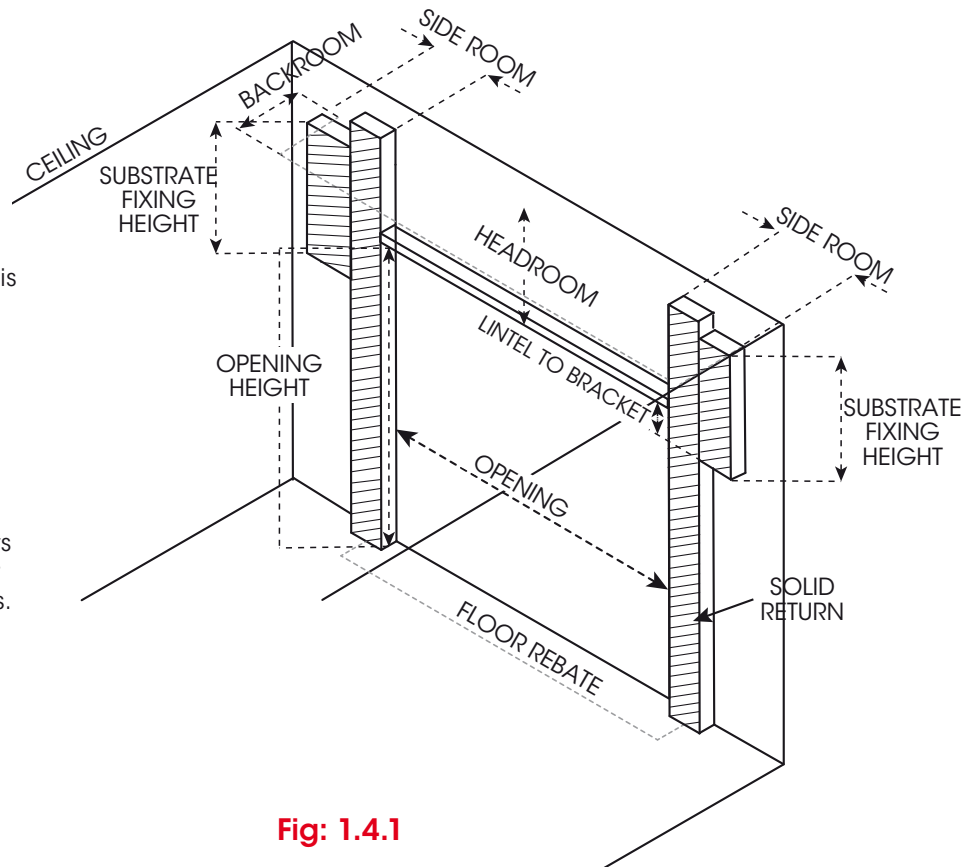

**Fig: 1.4.1**

#### 1.4.2 measurements

**opening width** - Check the width of the curtain with the width of the opening and ensure that when the fixing holes in the curtain are lined up with the fixing studs on the drum, the curtain overlaps on each side of the opening by 70mm, therefore shutter curtain, including clips should be 140mm wider. **(Fig 1.4.1)** Position the drum in front of the opening so that the drum tube (excluding the gear wheel) is exactly in the centre of the opening.

**opening height** - The shutter opening height indicates the distance between the ground and rubber seal at the bottom of the shutter, with shutter fully open.

**headroom** - A minimum headroom is required for all shutters. Refer to **Fig 1.4.2- 1.4.5** for measurements. If the shutter is installed lower into the opening, additional loss of shutter opening height will result.

**backroom** - A minimum backroom is required for all shutters. Refer to **Fig Fig 1.4.2- 1.4.5** for measurements. Extra room would be required for installing large shutters.

**side room** - The minimum required sideroom for shutters is dependent on the drive mechanism installed and whether the shutter has windlock guides. The measurement must extend beyond the top of the opening to provide fixing for the support brackets. Refer to **Fig Fig 1.4.2- 1.4.5** for measurements.

## 1.4.3 parts checklist

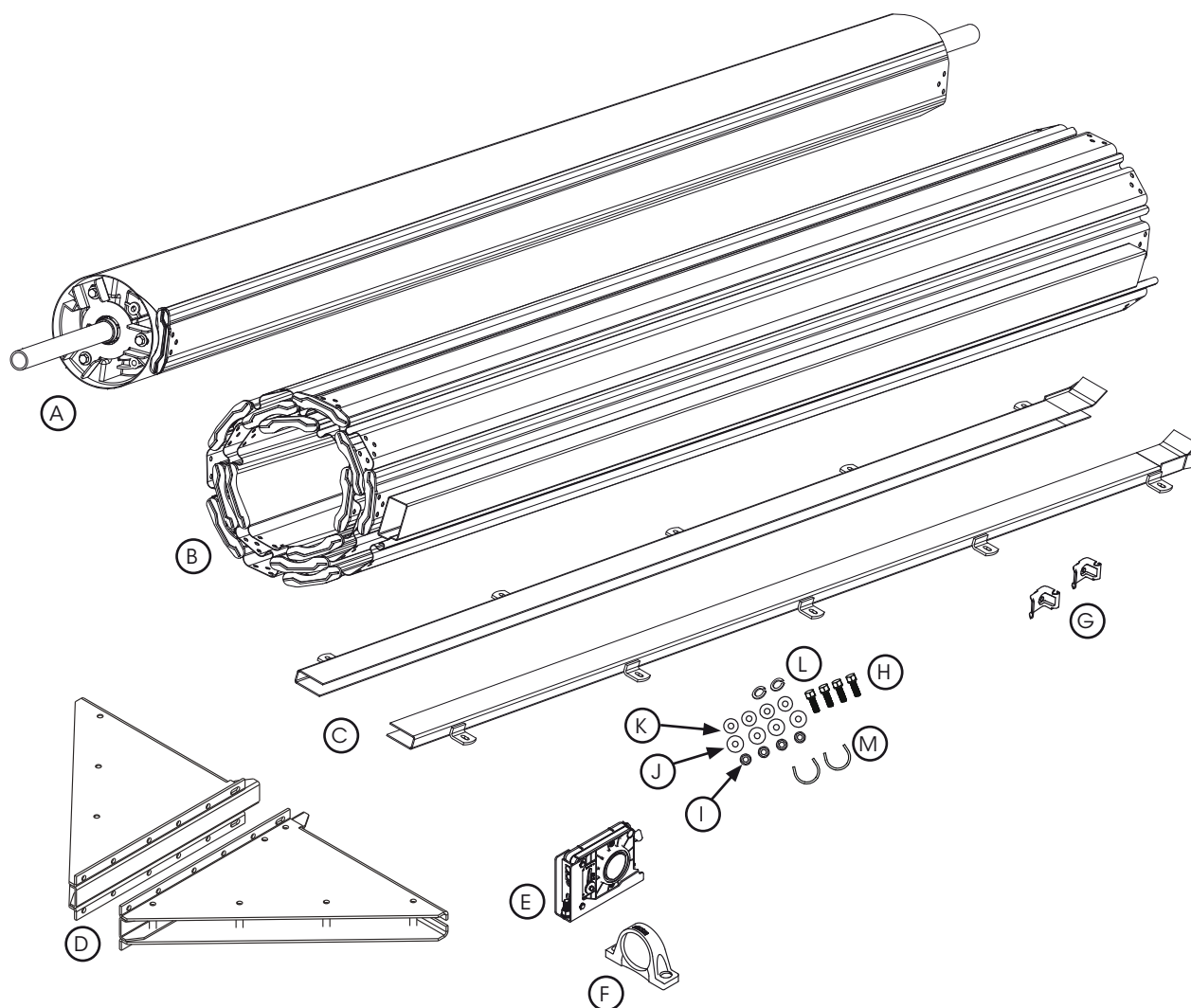
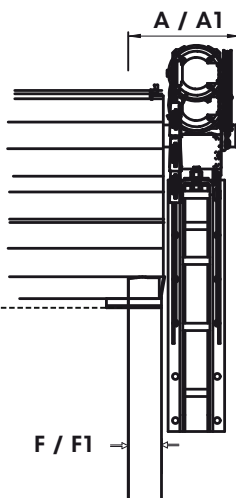
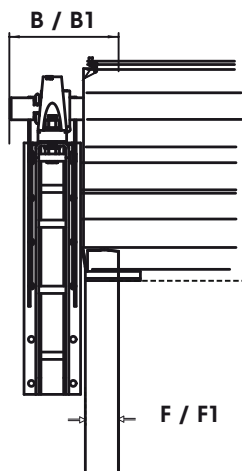

Fig: 1.4.2

ROLL-A-SHUTTER		RAS
ITEM	DESCRIPTION	QTY
A	STEEL DRUM	1
B	STEEL CURTAIN WITH CLIPS	1
C	SHUTTER GUIDES LEFT AND RIGHT HANDED	2
D	BRACKETS	2
E	SAFETY BRAKE	1
F	PILLOW BEARING 80MM	1
<b>SMALL PARTS BAG CONTAINING</b>		
G	BOTTOM RAIL STOPS AND SCREWS	2
H	BOLT M22X2.5X90 HEX-HD GRADE 8	4
I	NUT M22X2.5 GRADE 8 ZNPI	4
J	WASHER MUDGUARD M22X44X3.2XAP	4
K	WASHER FLAT M22X44X3.5 ZNPI	4
L	WASHER SPRING M22	2
M	SHAFT COLLARS (DIRECTLIFT)	2

**1.4.3 measurements direct lift / direct drive**  
**installation requirements Steel Direct Lift / Direct Drive**



**Fig: 1.4.2**

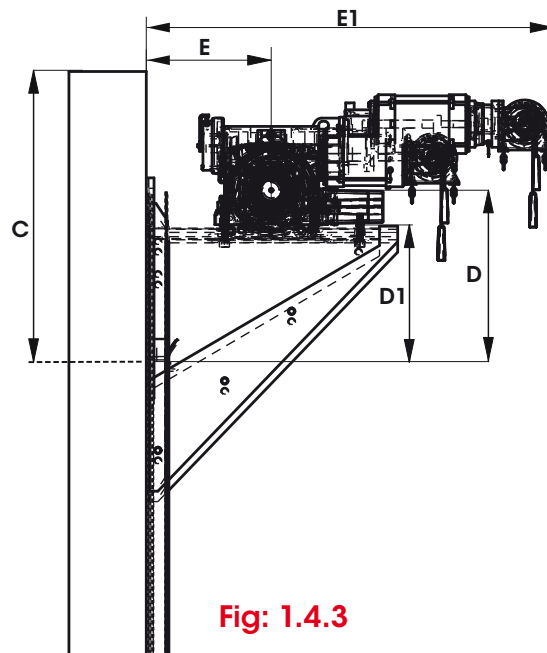

**Fig: 1.4.3**

**dimension table**

Door Model Code	Door height (mm)	Door width (mm)	Drum Size (mm)	Minimum Sideroom Opener End		Minimum Sideroom Plain End		Recommended Headroom	Axle to Lintel	Lintel to Bracket	Recommended Backroom		Width of Guide	
				W/L	Non W/L	W/L	Non W/L				Axle to Wall	Opener	W/L	Non W/L
				A	A1	B	B1				C	D	D1	E
RAS 6/100	up to 3000	up to 4200	219	315	295	315	295	636	418	Measurement determined by size of spindle. Refer to installing first bracket in installation manual.	248	1040	90	77
	3001 - 3900	up to 6000						650	425		255			
	3901 - 5100	up to 5700						694	447		277			
	5101 - 6000	up to 6000						730	465		295			
RAS 8/100	up to 3000	up to 4200	219					636	418		248			
	3001 - 3900	up to 6000						650	425		255			
	3901 - 5100	up to 5700						694	447		277			
	5101 - 6000	up to 6000						730	465		295			
RAS 10/100	up to 3000	up to 4200	219					600	400		230			
	3001 - 3900	up to 6000						650	425		255			
	3901 - 5100	up to 5700						700	450		280			
	5101 - 6000	up to 6000						730	465		295			
RAS 12/100	up to 3000	up to 4200	273					610	405		235			
	3001 - 3900	up to 6000	708					454	284					
	3901 - 5100	up to 5700	760					480	310					
	5101 - 6000	up to 6000	324					790	495		325			

1.4.4 measurements direct lift / chain drive

installation requirements Steel Direct Lift / Chain Drive

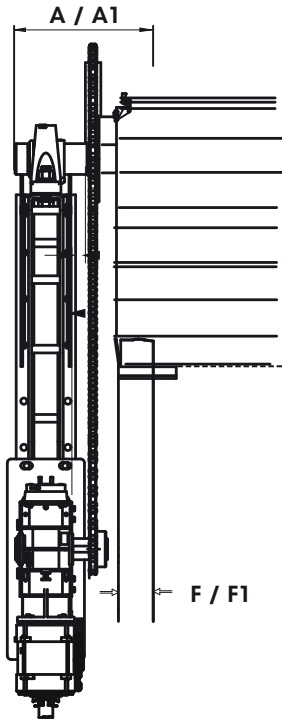

Fig: 1.4.4

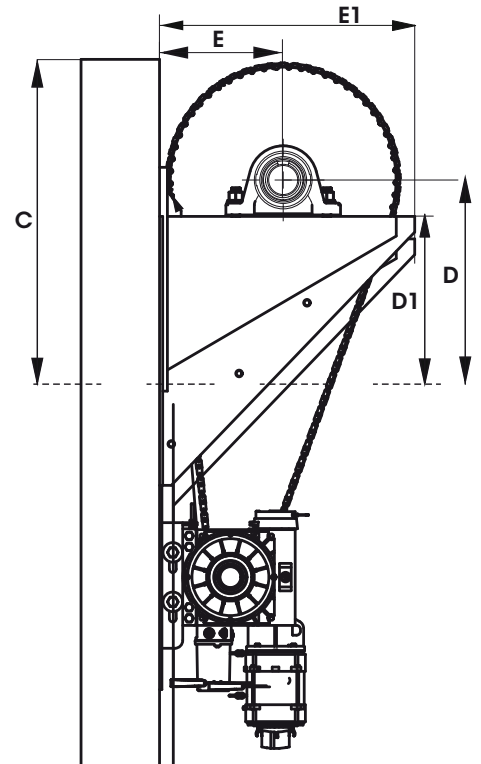
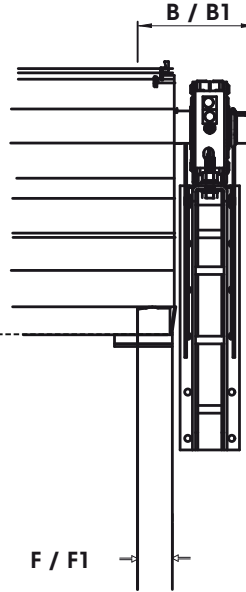

Fig: 1.4.5

dimension table

Door Model Code	Door height (mm)	Door width (mm)	Drum Size (mm)	Minimum Sideroom Opener End		Minimum Sideroom Plain End		Recommended Headroom	Axle to Lintel	Lintel to Bracket	Recommended Backroom		Width of Guide															
				W/L	Non W/L	W/L	Non W/L	Bundle to lintel			Axle to Wall	Bundle	W/L	Non W/L														
				A	A1	B	B1	C	D	D1	E	E1	F	F1														
RAS 6/100	up to 3000	up to 9000	219	353	337	331	305	636	418	D1	248	436	90	77														
	3001 - 3900	up to 8500						650	425		255	450																
	3901 - 5100	up to 8000						694	447		277	494																
	5101 - 6500	up to 7500						730	465		295	530																
	6501 - 6800	5405- 7000						810	505		335	610																
RAS 8/100	up to 3000	up to 9000	219					353	337		331	305			636	418	D1	248	436	90	77							
	3001 - 3900	up to 8500													650	425		255	450									
	3901 - 5100	up to 8000													694	447		277	494									
	5101 - 6500	up to 7500													730	465		295	530									
	6501 - 6800	5405- 7000													810	505		335	610									
RAS 10/100	up to 3000	up to 12000	219												353	337		331	305			660	430	D1	260	460	90	77
	3001 - 4200																					710	455		285	510		
	4201 - 5400		760																			480	310		560			
	5401 - 6500		790																			495	325		590			
	6501 - 9000		830																			515	345		630			
9001 - 10000	870	535	365	670																								
RAS 12/100	up to 3000	up to 12000	273	353	337	331	305			670			435	D1								265	470		90	77		
	3001 - 4200									768			484									314	568					
	4201 - 5400									820			510									340	620					
	5401 - 6500		850							525			355									650						
	6501 - 7500		860					530	360	660																		
	7501 - 9000		900					550	380	700																		
	9001 - 10000		910					555	385	710																		

Measurement determined by size of bearing and safety break. Refer to installing first bracket in installation manual.



## 1.5 tools and equipment

The following tools are needed to install Roll-A-Shutter® 6, 8, 10 & 12/100 Series.

- personal safety equipment
- comprehensive tool kit
- selected electric tools
- magnetic drill press
- electric welder
- lifting straps
- heavy duty rope
- scissor lift
- forklift
- crane
- chain blocks
- spring tensioning bars

## 1.6 specifications

Description	Type Name	Industrial Steel Slat Type Shutter							
		6/100		8/100		10/100		12/100	
Model code		RAS		RAS		RAS		RAS	
		Min	Max	Min	Max	Min	Max	Min	Max
Max Door Height		900	6000	900	6000	900	10000	900	10000
Max Door Width		900	7000	900	7000	900	12000	900	12000
<b>SHUTTER</b>									
Slat thickness		0.6mm		0.8mm		1.0mm		1.0mm	
Minimum shutter overlap each side		70mm		70mm		70mm		70mm	
Axle overlap on each side		350mm		350mm		350mm		350mm	
Drum Type	with chain OR opener	168mm		168mm		168mm		168mm	
Operation	Chain geared (below 25sqm)	•		•		•		•	
	optional motor	•		•		•		included	
Bottom Rails	Aluminium T section	•		•		•		•	
	Weatherseal	included		included		included		included	
	Box section	optional		optional		standard < 7000m(W)		standard < 7000m(W)	
<b>SLAT CONFIGURATION</b>									
Solid		•		•		•		•	
Slotted 19 x 101mm (13%)		•		•		•		•	
Slotted 32mm Round (14.5%)		•		•		•		•	
<b>GUIDES</b>									
Steel Channel, Galvanised 2.0mm steel, depth 77mm		•		•		•		•	
<b>LOCKS</b>									
External Bottom rail		Shoot Bolt		Shoot Bolt		Shoot Bolt		Shoot Bolt	
Internal & External slide bolts		•		•		•		•	
<b>Optional Extras</b>									
Door Opener		Axess Pro		Axess Pro		Axess Pro or GFA		Axess Pro or GFA	
Fixed or independent tapers		10mm	160mm	10mm	160mm	10mm	160mm	10mm	160mm
High Wind Option		•		•		•		•	
Mullions		•		•		•		•	

### 1.7 mounting weights

Due to the considerable variation in door weights, weights shown are intended to be used for guidance only and not taken as exact figures. Intermediate sizes can be approximated from the sizes listed.



**WARNING!** Weight information supplied is for installer to utilize correct lifting equipment. Failure to used correct equipment may result in death or damage to property.

all weight shown in kilograms

#### 6/100

height	width											
	2500		3000		4000		5000		7000		9000	
	CW	DW	CW	DW	CW	DW	CW	DW	CW	DW	CW	DW
2500	78	70.5	89.9	119	119.7	187	149.6	240.1	209.3	336	268.9	442
3000	85.6	107.5	120	94.2	137.1	187	171.2	240.1	239.6	336	307.9	442
4000	107.3	107.5	140	94.2	171.7	187	214.5	210	300.2	336		
5000	128.9	107.5	154.8	119	272.0	148.1	340	208.6	475.8	260.7		
6000	150.6	107.5	180.8	119	317.8	148.1	397.2	208.6	555.9	260.7		
6800									620	240.7		

#### 8/100

height	width											
	2500		3000		4000		5000		7000		9000	
	CW	DW	CW	DW	CW	DW	CW	DW	CW	DW	CW	DW
2500	113.1	86.7	167.9	72.6	181	138.8	226.2	173.4	329.4	264.7	423.4	354.5
3000	129.5	86.7	183.1	93.3	207.3	138.8	259	173.4	377.4	264.7	485.1	354.5
4000	162.4	86.7	213.9	129	259.9	138.8	324.8	173.4	473.2	264.7		
5000	195.3	86.7	257.2	129	312.5	138.8	390.6	173.4	569.1	234.7		
6000	228.2	86.7	300.5	129	365.1	138.8	456.3	173.4	664.9	234.7		
6800									741.6	234.7		

#### 10/100

height	width											
	2500		3000		4500		7000		8500		10000	
	CW	DW	CW	DW	CW	DW	CW	DW	CW	DW	CW	DW
2500	139.8	70.3	167.9	76.2	251.4	128.2	463.1	183.2	562.1	227.6	661.4	261.5
3000	152.5	73.1	183.1	96.9	255.6	198.5	470.7	301.2	571.3	362.5	672.2	348.8
4000	166.6	154.2	213.9	119	320.5	198.5	590.4	301.2	716.7	362.5	843.3	348.8
5000	200.4	154.2	257.2	119	402.4	153	685	215.4	831.6	247.3	978.5	319.2
6000	234.1	154.2	300.5	119	470.2	153	800.5	215.4	979.1	247.3	1150	319.2
6800							892.9	215.4	1084	247.3	1275	319.2

#### 12/100

height	width											
	2500		4000		6000		8000		10000		12000	
	CW	DW	CW	DW	CW	DW	CW	DW	CW	DW	CW	DW
2500	148.6	132.5	237.9	212	356.6	318	475.3	424	594.1	530	712.8	636
4000	213.6	132.5	341.8	212	512.5	318	683.2	424	853.9	530	1024	636
6000	300.2	132.5	480.3	212	720.3	318	960.3	424	1200	530	1440	636
8000	386.8	132.5	618.9	212	928.2	318	1237.4	424	1546.7	530	1856	636
10000	473.4	132.5	757.5	212	1136	318	1514.5	424	1892.1	530		

CW	CURTAIN WEIGHT
DW	DRUM WEIGHT



## 2.0 installation

### 2.1 install first bracket

dimension table						
	B&D Model	plain end		D	D1	D2
		B	B1			
		W/L	non W/L			
Direct Drive	RS0654	295	295	Refer to 1.4.3 & 1.4.4 for measurement	See formula below	42
	RS0655					49
	RS0656					49
	RS0657					60
Chain Drive	RS0650	331	305			95
	RS0651					118
	RS0652					118
	RS0653					145

**bracket height position (  $D1 = D - D2$  )**

Fig: 2.1.1

- Look at the safety brakes (E) supplied with the shutter and match the B&D model number to the above diagrams Fig 2.1.1 and 2.1.2 for bracket height and sideroom position for the plain end bracket.
- Mark 6 hole positions using slots of the bracket (D).
- Drill holes, then attach bracket using suitable fasteners as per 1.2 substrate fastener recommendations.

**WARNING!** The installer must select and use fasteners appropriate to the material into which they are being fixed.

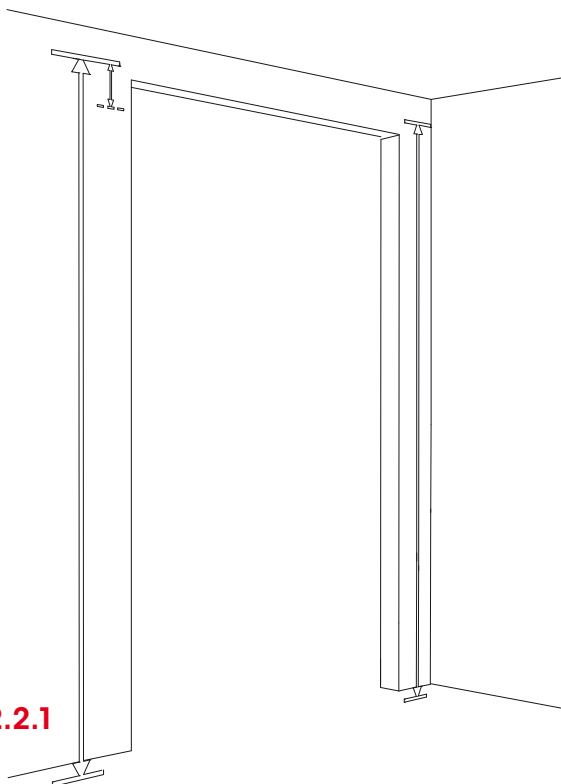

Fig: 2.2.1

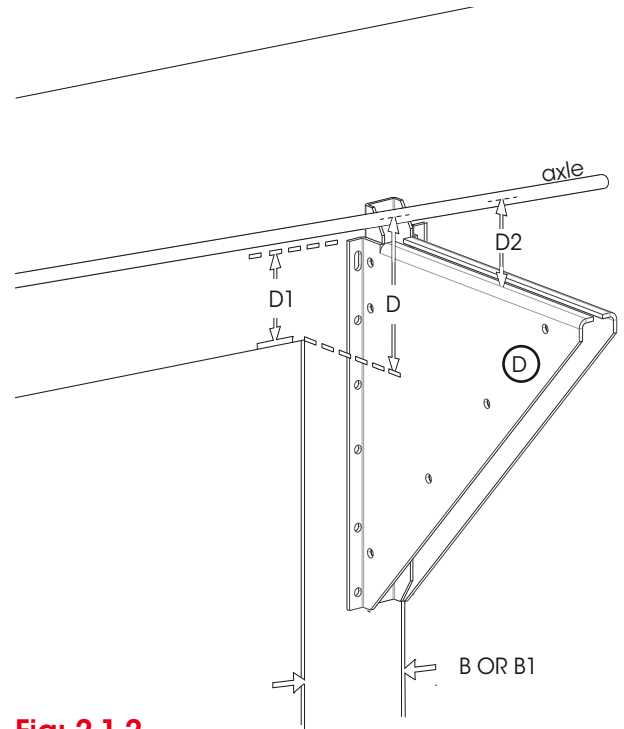

Fig: 2.1.2

### 2.2 install second bracket

dimension table					
	B&D Model	opener end		for bracket position see formula below	D2
		A	A1		
		W/L	non W/L		
Direct Drive	RS0654	295	295	for bracket position see formula below	120
	RS0655				120
	RS0656				120
	RS0657				135
Chain Drive	RS0650	353	337		115
	RS0651				180
	RS0652				190
	RS0653				190

**bracket position = Axle level - D2**

**CAUTION:** The axle must be perfectly level for the shutter to operate.

- Using a laser level or water level, mark the position on the wall for the centre of the axle (Fig 2.2.1).
- Re-check levels, determine opener end bracket position as per calculation above, then drill and affix with fasteners as with first bracket.



## 2.2 position the drum assembly on brackets

### 2.2.1 direct drive position



**TWO PERSON:** this product requires two persons to secure onto the brackets. Use proper techniques and equipment to raise the drum up and onto the brackets. Refer to weights table in **section 1.7** for equipment lifting capacity.

		dimension table		
		height (mm)	width (mm)	E
Direct Drive	RAS 10/100	up to 3000	up to 4200	230
		3001 - 3900	up to 6000	255
		3901 - 5100	up to 5700	280
		5101 - 6000	up to 6000	295
	RAS 12/100	up to 3000	up to 4200	235
		3001 - 3900	up to 6000	284
		3901 - 5100	up to 5700	310
		5101 - 6000	up to 6000	325

- With the drum the correct way around (curtain rolls down rear of the opening) remove the slat mounted to the drum, keeping the slat, nuts and bolts to the side.
- Carefully lift the drum up and over the brackets (D) using suitable lifting equipment - to avoid damaging the drum.
- Before lowering onto the brackets slide the bearing (F) and drive unit onto the ends, make sure they are correctly orientated.
- Position onto the brackets as per fig 2.2.1 and 2.2.2 using measurement E from the dimension table, slide the axle through and fit shaft collars (M). When satisfied the shaft collars can be tack welded in place.
- Secure bearing and drive unit in place with Hex Head Bolts (H), spring washers (L), flat washers (K) and M22 nuts (I) as shown. Tighten the nuts on the bearings evenly to a torque of 40Nm or 30 ft.lb.

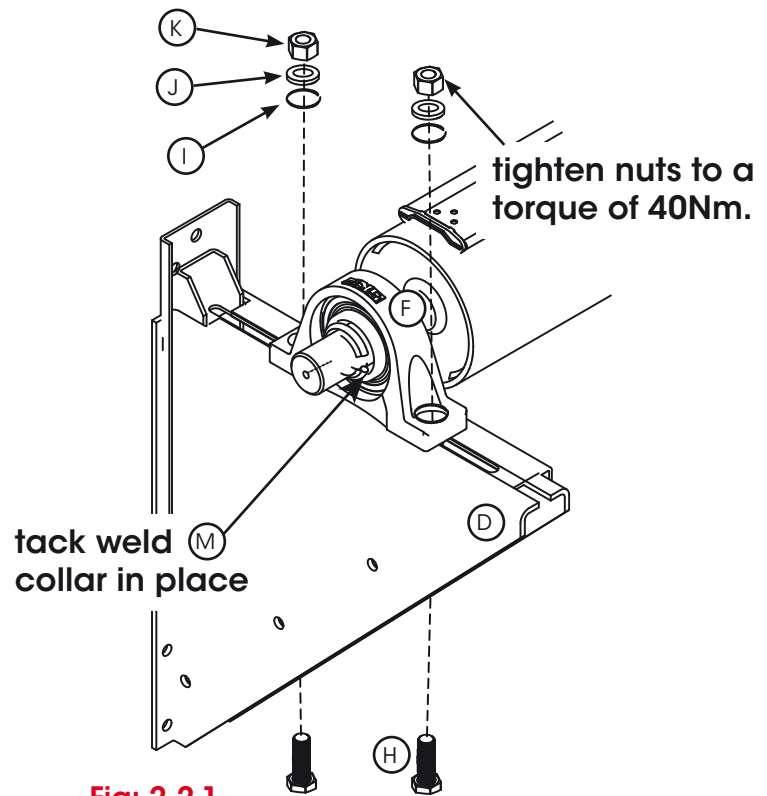

Fig: 2.2.1

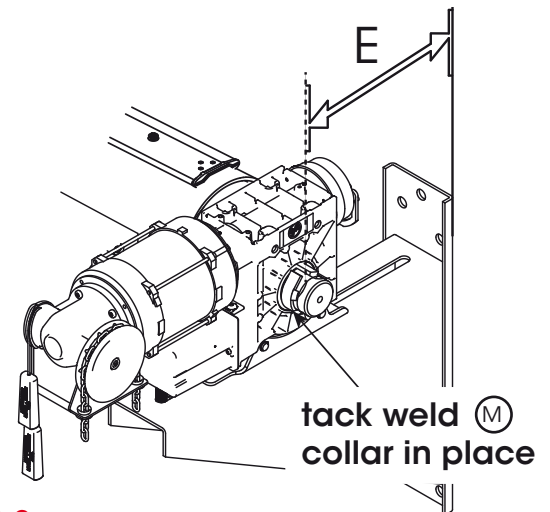

Fig: 2.2.2

2.2.2 chain drive position



**TWO PERSON:** this product requires two persons to secure onto the brackets. Use proper techniques and equipment to raise the drum up and onto the brackets. Refer to weights table in **section 1.7** for equipment lifting capacity.

dimension table				
		height (mm)	width (mm)	E
Chain Drive	RAS 10/100	up to 3000	up to 12000	260
		3001 - 4200		285
		4201 - 5400		310
		5401 - 6500		325
		6501 - 9000		345
		9001 - 10000		365
	RAS 12/100	up to 3000	up to 12000	265
		3001 - 4200		314
		4201 - 5400		340
		5401 - 6500		355
		6501 - 7500		360
		7501 - 9000		380
		9001 - 10000		385

- a) With the drum the correct way around (curtain rolls down rear of the opening) remove the slat mounted to the drum, keeping the slat, nuts and bolts to the side.
- b) Carefully lift the drum up and over the brackets using suitable lifting equipment – to avoid damaging the drum.
- c) Before lowering onto the brackets slide the small chain sprocket, bearings (F) and safety brake (E) onto the ends, make sure they are correctly orientated.
- d) Fit the opener plate and opener as shown in Fig 2.2.3 using suitable fasteners as per **1.2 substrate fastener recommendations**.
- e) Position the drum onto the brackets as per fig 2.2.3 and 2.2.4 using measurement E from the dimension table, when satisfied the shaft collars (M) can be tack welded in place.
- f) Secure bearing and safety brake in place with Hex Head Bolts (H), spring washers (L), flat washers (K) and M22 nuts (I) as shown. Tighten the nuts on the bearings evenly to a torque of 40Nm or 30 ft.lb.
- g) Fit the manual chain to the chain wheel. Align the sprockets of the opener and small chain sprocket and tighten.
- h) Tension the drive chain and ensure the sprocket grub screws are tightened.
- i) The safety brake must be connected to the opener via a 2core wire (not supplied) to ensure the safety brake operation is active.

**WARNING!** The 2core wire **MUST** be secured away from any moving parts.

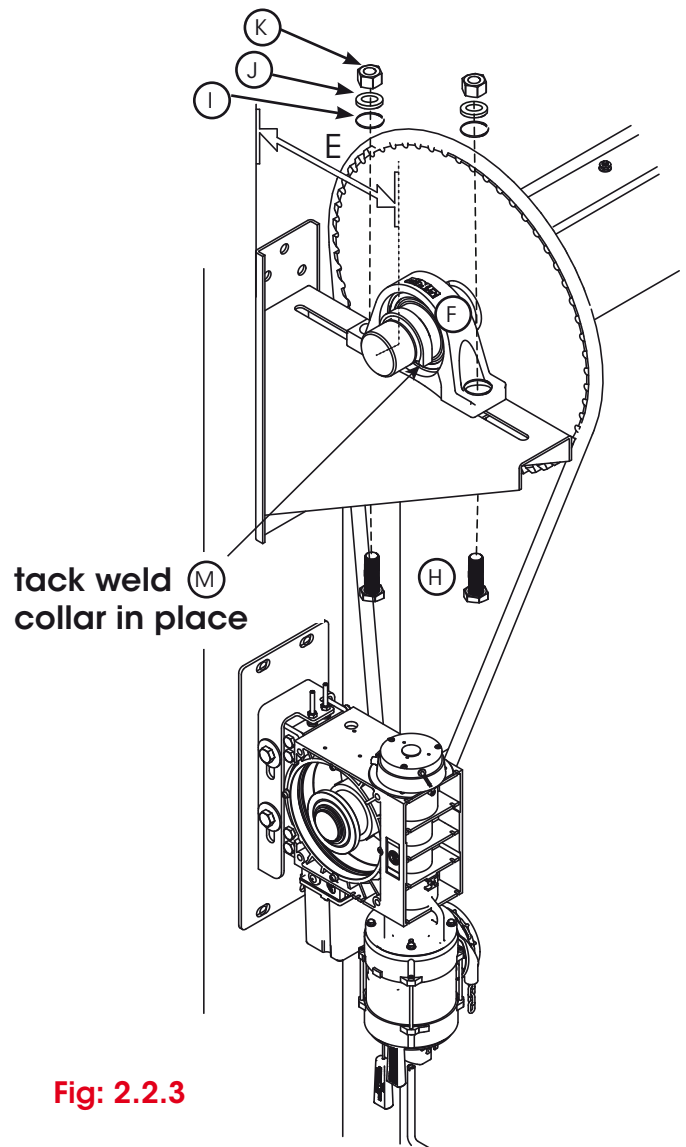

Fig: 2.2.3

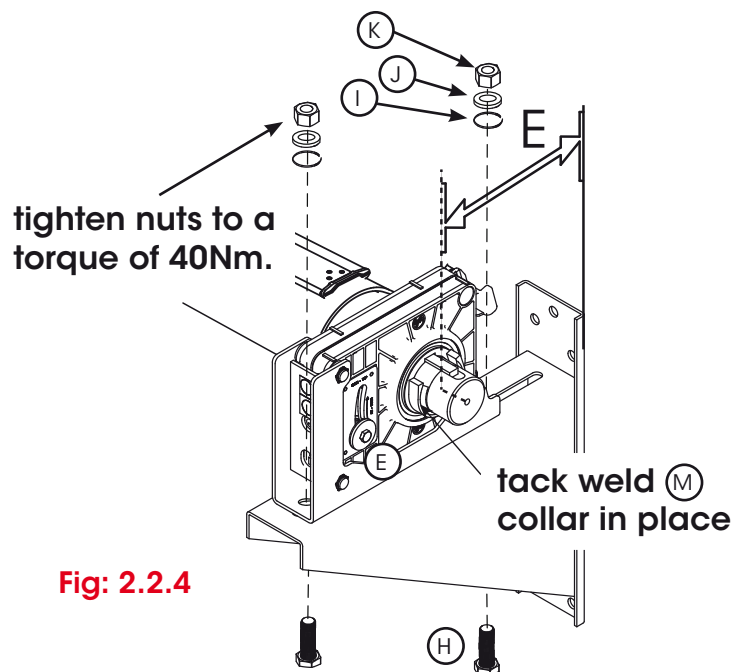

Fig: 2.2.4



## 2.3 preparing and fitting the curtain

- The curtain can now be prepared; make sure it is off the ground so that lifting slings or fork lift tines can be fitted under it.
- Make sure that it is the correct way around with the curtain rolling away from the forklift and the top end slat of the curtain is on the top of the roll.
- Remove the packaging and strapping around the curtain.
- Using a screwdriver twist the end clip on the top slat so that the slat previously removed can be slid into the top slat. When fully inserted twist the end clip back into position.
- The bundle of curtain now needs to be secured in a roll as it was in the original packaging, this should be done about a metre from each end using the appropriate ropes wound around 2-3 times.  
**NOTE:** For shutters wider than 5 metres an additional centre rope should be used.



**WARNING!** The lifting slings **MUST** be able to lift the full curtain weight. Refer to curtain weight table in section 1.7.

## 2.4 fitting the curtain to the drum



**WARNING!** This step requires proper techniques and equipment to raise the curtain up to the drum. Refer to weights table in section 1.7 for equipment lifting capacity. Failure to have appropriate equipment and an exclusion zone can cause death or damage to property.

- Lift the curtain into position using a overhead crane or forklift. Ensure adequate protection is placed around the curtain to avoid damage. **NOTE:** If using the crane method and a spreader bar is not available ensure the straps are placed as wide apart as possible.
- Carefully lift to within 300mm under the drum, Figure 2.4.1, by means of two other lengths of heavy gauge rope sling the curtain roll up to the drum as shown in the illustration. Make sure the end of the curtain is on top of the roll and able to be raised up.
- When you are sure the curtain is held securely by several wraps of heavy rope release the lifting straps or forklift slowly allowing the wraps of rope to take the weight of the curtain.
- Switch power on to the opener and operate opener to rotate the drum and unroll the curtain sufficiently to allow the fixing slat to be passed up between the lintel and the drum. Rotate the drum and curtain until the fixing studs on the drum and the curtain fixing slat can be aligned. Secure the hauling chain (if installed) and fix the curtain to the drum with the studs nuts and washers provided.
- Release the hauling chain, operate opener to rotate the drum to roll the curtain fully onto the drum, make sure the bottom rail is at about 5 o'clock. Secure the hauling chain to prevent the drum from turning and tighten the rope slings.
- The assembly is now ready for the guides to be installed.

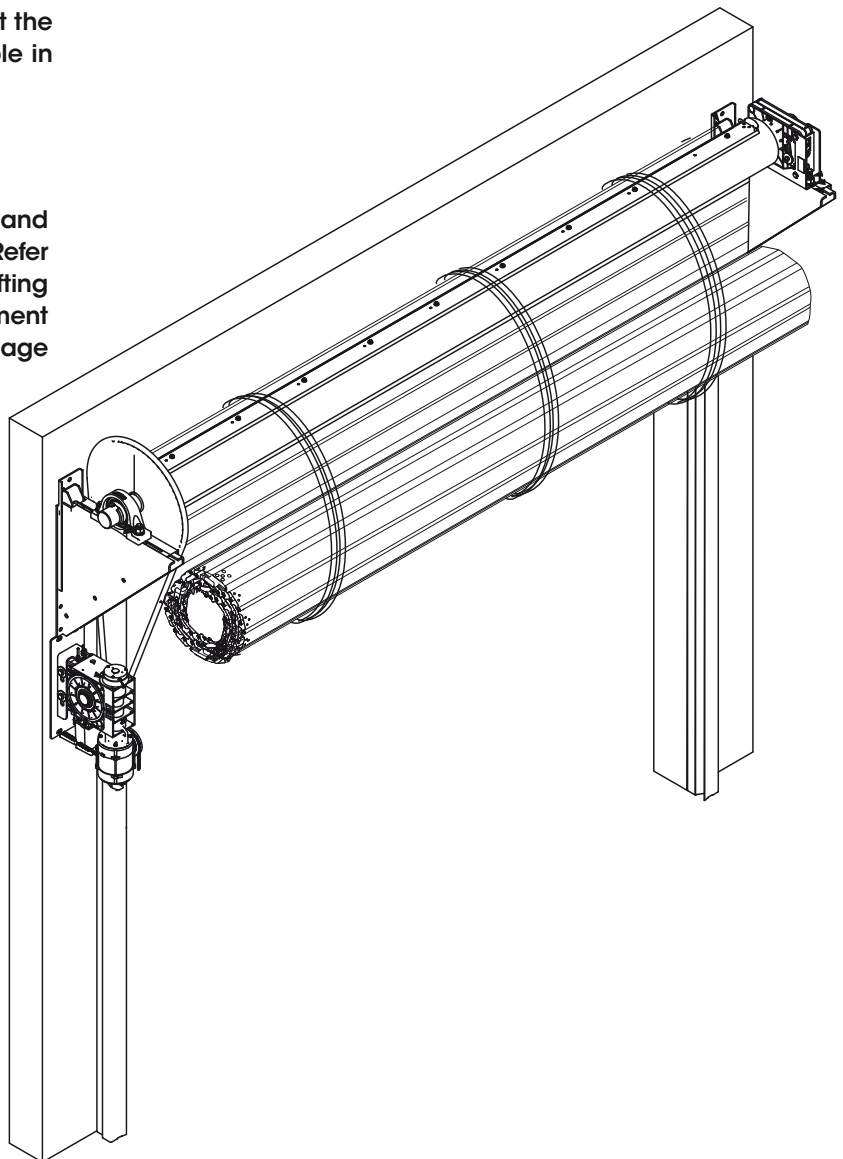

**Fig: 2.4.1** Chain drive product shown

## 2.5 install the guides

### 2.5.1 positioning the guides

Guides must be correct length. The guide stop should be level with the bottom of the lintel for aluminum bottom rail installation. Guides can be shortened by cutting the bottom of guide.

- Position guides  true and plumb at each side of the opening. Allow 3-5 mm of working clearance between the shutter and the inside of each guide as per **Fig 2.5.1**. For Windlock setup refer to **Fig 2.5.2**.
- Using the guides brackets as a template (**Fig 2.5.3**) mark out and drill holes in the wall to match the spacing of the fixing bolt holes in the guides bracket.
- Mark, drill holes and loosely fix the first guide. Select the appropriate fixing as per **Section 1.2**.
- Using a laser level, transfer position of top of first guide arm to opposite side of opening, then mark, drill and fix second guide. Ensure that the guides are secure.
- Apply general purpose grease to the internal surface of the guide to safeguard smooth operation.

 **CAUTION:** The guides must be perfectly level for correct shutter operation.

 **WARNING!** All High Wind installations must adhere to fixing types and centres as referenced in the [B&D High Wind Drawings](#).

 **tip** If securing to uneven blockwork, packers may be required behind clips, to prevent them twisting out of square; also ensure that clips are positioned on secure blocks, not mortar.

### 2.5.2 install the bottom rail stop

- Carefully remove the rope slings holding the curtain, disengage opener and lower bottom rail into the guides.

 **WARNING!** When the bands holding the shutter curtain rolled up are removed, there will be a strong tendency to rise and revolve. If uncontrolled, the rapidly unrolling shutter could cause damage or injury.

- Fit bottom rail stops  using self locking nuts provided. Allow the door to rise and rest against the head stop (**Fig 2.5.4**)

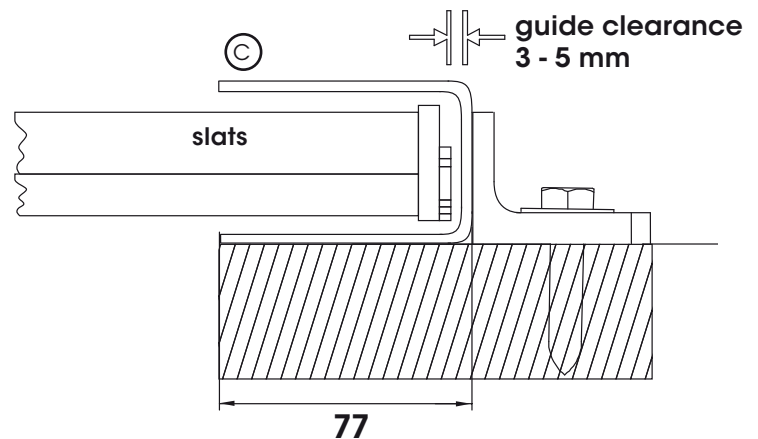

**Fig: 2.5.1 (standard guide)**

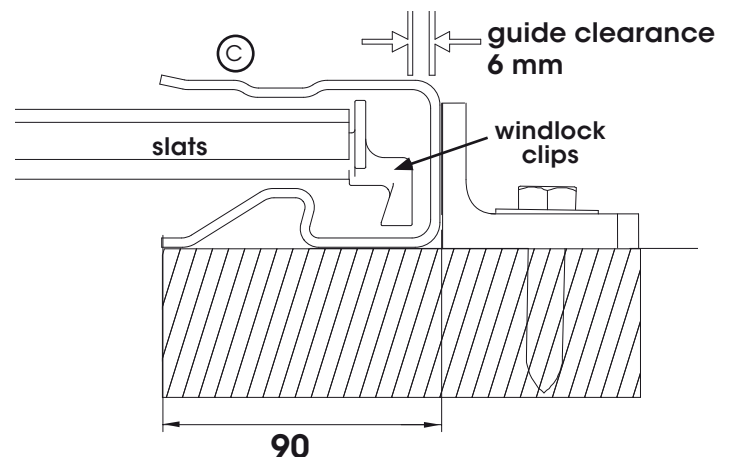

**Fig: 2.5.2 (windlock guide)**

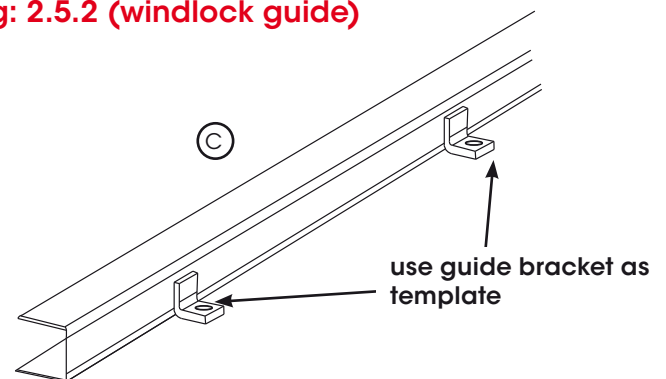

**Fig: 2.5.3**

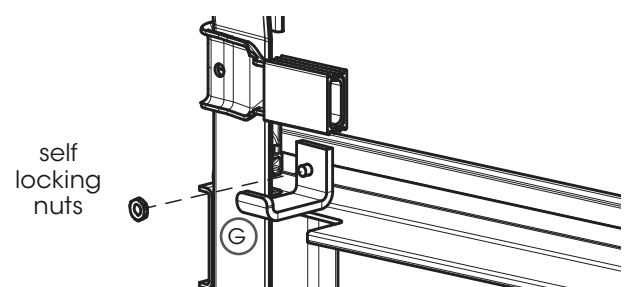

**Fig: 2.5.4**

## 3.0 after installation care

### general care of your Roll-A-Shutter®

#### cleaning

Your B&D Roll-A-Shutter® has been manufactured from galvanised or powder coated steel, which is one of the best paint films commercially available today. However, all exposed surfaces require some attention to guard against the premature onset of corrosion and any other harmful atmospheric effects. In our atmosphere there are harmful deposits that gather on the door surface and if not removed regularly, will seriously affect the appearance and life of the door.

**Note:** Be aware of electric shock.

Washing of the door with clean water and a cloth is recommended – particular care should be taken to clean areas of the door not normally washed by rain.

#### regular maintenance required

B&D recommends that you check the operation of your Roll-A-Shutter® at least every six months (more regularly in extreme environments or frequent use). The effort required to manually open and to manually close the door should be about the same (if door has an automatic opener, put into manual mode before testing door).

**Note:** The door guide grease should be cleaned out and replaced least annually or more frequently in extreme conditions.

If the door is difficult to operate in either direction (up or down) then check that the inside surfaces of the guides are clean and free of obstructions.

If the door is still difficult to operate, then your door will need a service to adjust the spring tension and possibly other operational parts of the door.

This service should only be carried out by an experienced door technician, using the correct tools.

If you have an automatic opener fitted to your door, it is particularly important that you ensure the optimum operation of the door, otherwise you may reduce the effective life of the opener.

To keep your door running well, it is recommended that your door be serviced, by an experienced door technician, every 12 months (more regularly in extreme environments or frequent use), or earlier if required.

#### spring tension

It is natural for springs to lose tension over time. When spring tension is adjusted or when your door is first installed it is usual to apply a little more tension than is required for balanced operation, to allow for the normal "settling in" of the springs.

**WARNING: The springs on the door are under extreme tension. On NO account should they be adjusted by an inexperienced person. B&D recommends regular servicing and safety checks be carried out at least annually, more frequently in extreme conditions or in high use environments.**

#### warranty

B&D Roll-A-Shutter® is covered by a 12 month warranty for complete door and parts, surface (excludes salt corrosion).

Warranty conditional on proper care as recommended above. Full details of the warranty are available from [bnd.com.au](http://bnd.com.au)

### b&d doors office locations

Head Office	6-8 Fiveways Blvd, Keysborough 3073	Phone (03) 9791 2000
New South Wales	34 Marigold St, Revesby 2212	Phone (02) 9722 5555
Queensland	17 Oasis Court, Clontarf 4019	Phone (07) 3883 0200
Victoria	147-153 Canterbury Rd, Kilsyth 3137	Phone (03) 9237 7766
South Australia	23 Frederick Rd, Royal Park 5014	Phone (08) 8440 4747
Western Australia	96 Mulgul Rd, Malaga 6090	Phone (08) 9247 8777
International/Export	34 Marigold St, Revesby 2212	Phone +61 (0)2 9722 5555

your representative is

**b&d**

Prefix trademarks are the property of B&D Australia Pty Ltd. B&D Doors & Openers is a division of B&D Australia Pty Ltd. ABN 25 010 473 971. © 2018 B&D Australia Pty Ltd.

[www.bnd.com.au](http://www.bnd.com.au)