

**b&d**

# Roll-A-Door®

## Series 3

installation instructions

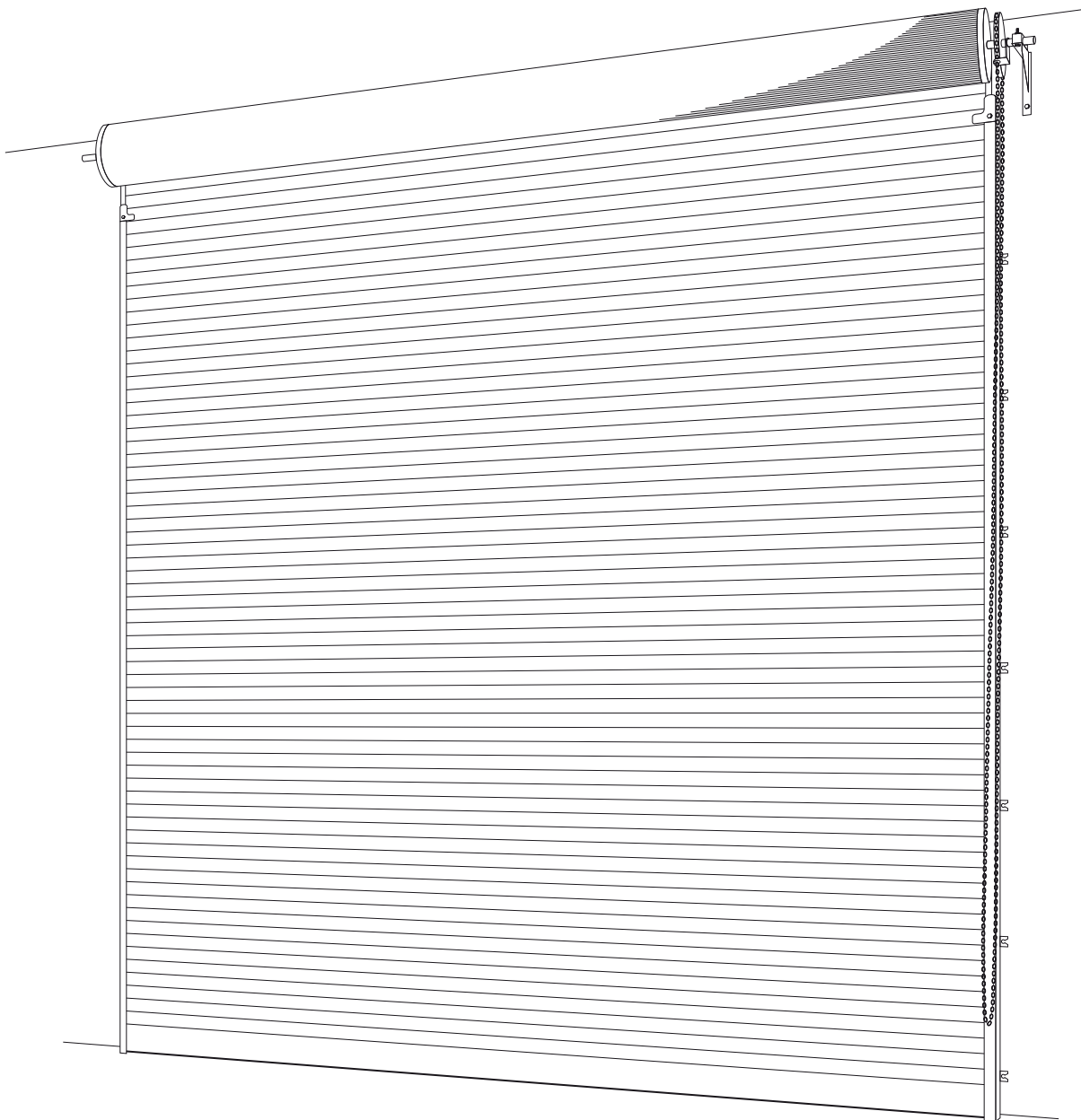

These instructions are intended for professional garage door installers. All references are taken from inside looking out.

DOC# 165019\_07  
RELEASED: 27/11/23

[www.bnd.com.au](http://www.bnd.com.au)

**b&d**

## Contents

<b>1.0 before you start</b>	<b>3</b>
1.1 installation safety warnings	3
1.2 substrate fastener recommendations	4
1.3 preparation	5
1.4 before installation	5
1.4.1 requirements	5
1.4.2 measurements	5
1.5 parts checklist	7
1.6 initial calculations	7
<b>2.0 installation</b>	<b>8</b>
2.1 install first bracket	8
2.2 install second bracket	8
2.3 place door on brackets	9
2.4 install guides	10
2.5 tension the springs	11
2.5.1 tensioning and adjustments	11
2.5.2 creating proper guide lead-in	11
2.6 locking	12
2.6.1 centre lift lock (only with R3W & R3F)	12
2.6.2 internal waist high slide bolt (R3I)	12
2.6.3 high wind centre lift lock (only with R3W & R3F)	13
2.7 troubleshooting	14
2.8 centralise the axle when door is mounted	14
2.9 adjusting spring tension	15
<b>3.0 appendix</b>	<b>16</b>
3.1 after installation care	16

# 1.0 before you start

## 1.1 installation safety warnings

This B&D Roll-A-Door is designed and tested to provide security, attractive appearance and smooth , low effort operation provided it is installed and operated in strict accordance with the following safety warnings. Failure to comply with the following instructions may result in death, serious personal injury or property damage.

**NOTE:** No guarantee will be given or responsibility accepted by the manufacturers if the door is not installed as instructed.



### WARNING!

Crush injury from unsecured door

Tension Springs

- Place a 2 metre exclusion zone around area under the garage opening while installing door. If sufficient area is not available DO NOT install door.
- Do not move under a door while it is on the door support (or lifting device).
- Follow the installation instructions.
- Fit door support (or lifting device) snugly under door before lifting.
- Ensure door support (or lifting device) is on flat ground.
- Ensure the door is immediately fastened to the bracket with the "U" Bolt.
- Ensure no-one walks under a door sitting on brackets.
- Ensure door is correctly secured at all times when making adjustments.
- Ensure the correct length pipe wrench is utilised.
- Ensure that pipe wrench is fitted correctly to the axle and if it is gripped onto the axle do not underestimate the tension in the spring when undoing the clamps.
- Ensure correct bolts are tightened or loosened to ensure there is no release or controlled release of energy from the spring through the pipe wrench.
- Keep head clear of the pipe wrench at all times.



### ELECTROCUTION!

- Check risk assessment for any highlighted electrical power concerns.
- Ensure power source is isolated prior to commencement of job.
- Turn off electricity to site when necessary.
- Wear rubber soled footwear.



### LACERATION:

- Wear appropriate PPE (Dyneema cut off gloves) and keep hands well clear of pinch points.
- Follow instructions explicitly, particularly for the installation of some parts of the doors, as the unrolled cut out edges presents a very sharp edge.



### CAUTION:

Muscular strain

Fall from ladder

Hand Tools

Entanglement

- Practice correct lifting techniques when required to lift the door.
- Use mechanical aids such as lifting devices, forklift and cranes where possible.
- Avoid twisting.
- Use correct technique of knotted rope installation aids.
- Ensure ladder is the correct type for job.
- Ensure ladder is on flat firm ground that will take the weight without the legs sinking.
- Ensure user has 3 points of contact while on ladder.
- Wear appropriate PPE and utilise operators manual of all tools.
- Use appropriate noise/hearing protection in the form of ear plugs or ear muffs.
- Ensure appropriate fire protection available and housekeeping to ensure that flammable liquids or materials are removed from the area of work.
- Keep hands and loose clothing clear of moving door and guides at all times.
- When a mechanical aid is not used this product requires a two person lift to raise onto the brackets. Use proper techniques and equipment to lift the door from the trailer and up onto brackets.



### TWO PERSON LIFT:

## 1.2 substrate fastener recommendations

**WARNING!** Coach bolts/screws are NOT suitable for windrated doors. Refer to High Wind drawings on the B&D Website.

**WARNING!** The installer must select and use fasteners appropriate to the material into which they are being fixed.

### important notes

- a) For installation to materials not covered in the chart, the installer should seek expert advice from a qualified builder.
- b) Minimum length of fastener does not exclude use of longer lengths. Decision must be made by fitter to ensure adequate strength.
- c) Recommendations for old materials or materials not in good condition are not included. If in doubt about the strength of the material seek specialist advice.
- d) Fasteners for brackets in masonry should be at least 8mm x 75mm long or metric equivalent.
- e) Use the washers supplied in the parts bag to all fixings.

material	fastener type(s)	diameter or type	length of fastener (see note)	BKT	GUIDE
New Solid Brick	Coach Bolts (Hex Lag Screw) and washers - combined with wall plugs	5/16" x	50mm		•
		5/16" x	80mm	•	•
	Macplugs (wall plugs) to suit above	5/16" x	50mm		•
		5/16" x	80mm	•	•
	HLC Sleeve Anchors (Dyna Bolts) with washers	12mm x	55mm	•	
New Hollow Brick	Screw Masonry Flange Hex Head (M8 x75)	8mm x	75mm	•	•
New Solid Concrete	Coach Bolts (Hex Lag Screw) and washers - combined with wall plugs	5/16" x	50mm		•
		5/16" x	80mm	•	•
	Macplugs (wall plugs) to suit above	5/16" x	50mm		•
		5/16" x	80mm	•	•
	HLC Sleeve Anchors (Dyna Bolts) with washers	12mm x	55mm	•	
Steel Framing e.g. BHP Framing (with rear access)	Hex Head Bolt Zinc Plated, Hexagon Nuts Zinc Plated, Washers Zinc Plated	5/16" x	1"		•
		3/8" x	1"	•	•
		10mm x	25mm	•	•
		12mm x	25mm	•	
Heavy Gauge Steel	Hex Head Tek and washers	14-20 x	22mm	•	•
Light Steel Framing e.g. BHP House Framing (no rear access)	Heavy Duty Kap Toggle	10mm x	100mm	•	•
		12mm x	100mm	•	
	Hex Head Tek and washers	6-10 x	20mm		•
New Timber	Coach Bolts (Hex Lag Screw) and washers	5/16" x	50mm		•
		5/16" x	80mm	•	•
	Hex Head Tek and washers	14-10 x	50mm	•	•

### BRICK CONSTRUCTION

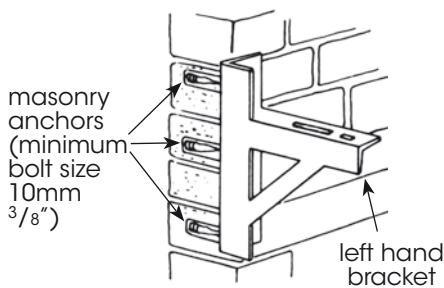

### STEEL CONSTRUCTION

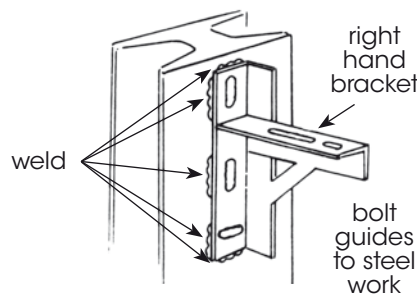

### SECURE GUIDE

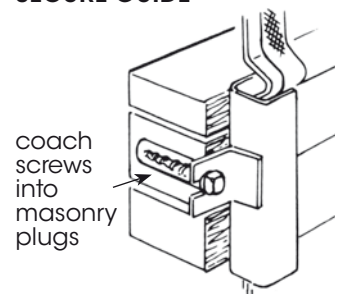

### MASONRY BLOCK CONSTRUCTION

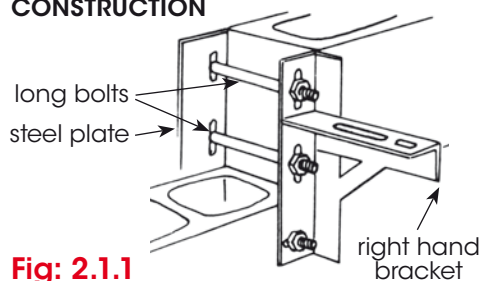

**WARNING!** Masonry blockwork should be properly filled and reinforced if brackets are to be mounted directly to blockwork with masonry anchors. Where the blockwork is not solidly filled but structurally sound, long bolts should be passed through the blockwork using suitable steel plates under bolt heads.

Special consideration should be given to brick type and construction of wall, to ensure satisfactory fixing e.g. welding detail if fixed to steel.

Fig: 2.1.1



### 1.3 preparation



**WARNING!** If you need to remove an old door prior to installing a B&D door ensure to:

- Roll the door up and place a secure tie around the middle
- Place door support on flat ground
- Fit door support snugly under door before loosening the brackets or locating U bolts.
- Slowly undo bolts to release the spring tension and the door from the brackets.
- Slowly lift the door from the brackets keeping it balanced as it is lowered to the ground.

### 1.4 before installation

#### 1.4.1 requirements

**mounting** - The door is designed to be mounted behind the opening.

**obstructions** - Ensure that the surface where the door will be fitted is flush and smooth, and the area behind the opening is free from any protrusions.

**structural suitability** - Ensure the opening is strong enough to support the door. If unsure, consult a builder.

**level and plumb** - The door must be installed in an absolutely level position, if opening is not level and square, appearance and/or sideroom requirements will be affected. The floor should be level or recessed across the opening to avoid gaps.

#### 1.4.2 measurements

**opening width** - As the standard door overlaps each side by 50mm or more, the door should be 100mm wider than the opening. A wider door can be fitted as long as additional sideroom and fixing is available. (Fig 1.4.1a) Wind-Locked doors require additional overlap dependent on the substrate, consult the B&D High Wind Certification Drawings for more detail.

**opening height** - The door opening height (or drive through clearance) indicates the distance between the ground and rubber seal at the bottom of the door, with door fully open. Max drive through heights for each door height are listed in Fig 1.4.1b.

**headroom** - A minimum headroom is required for all doors. Refer to Fig 1.4.2 - 1.4.5 for measurements. If the door is installed lower into the opening than shown in Fig 1.4.2, additional loss of door opening height will result.

**backroom** - refer to Fig 1.4.2 - 1.4.5 for measurements.

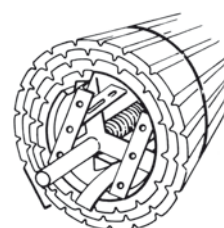

**DO NOT CUT THE PACKAGING THAT HOLDS THE DOOR IN A ROLL**

At a later stage during the installation you will be told just when to cut the packaging. Remove brackets, guides and bag of small parts from each end of the door roll.

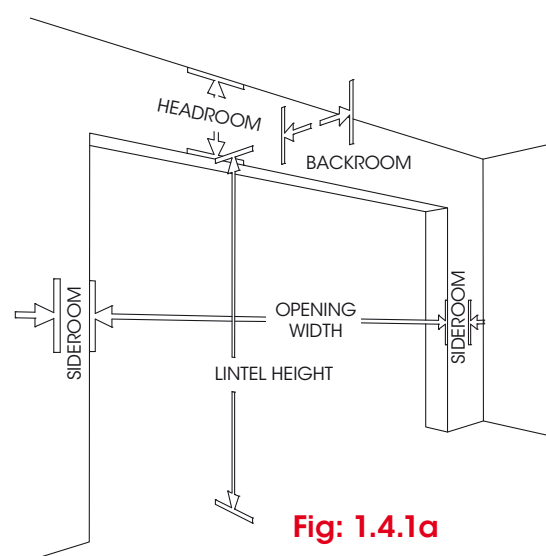

**Fig: 1.4.1a**

**Fig: 1.4.1b**

Description	Name Type	Rollmasta		Squareline Deluxe		Industrial	
		Series 3		Series 3		Series 3	
Model code		R3F		R3W		R3I	
Door & Max Drive Through Heights (mm) (non-Wind-Lock Doors)	Door Height	Max Drive Height	Door Height	Max Drive Height	Door Height	Max Drive Height	
	1200	1200	-	-	1200	1200	
	1800	1700	1800	1700	-	-	
	2100	2000	2100	2000	2100	2000	
	2400	2300	2400	2300	2400	2300	
	2700	2600	2700	2600	2700	2600	
	3000	2900	3000	2900	3000	2900	
	-	-	-	-	3300	3300	
	-	-	-	-	3600	3600	
Max Door Width (including overlap)		5100mm		5500mm		5500mm	

1.4.2 measurements continued...

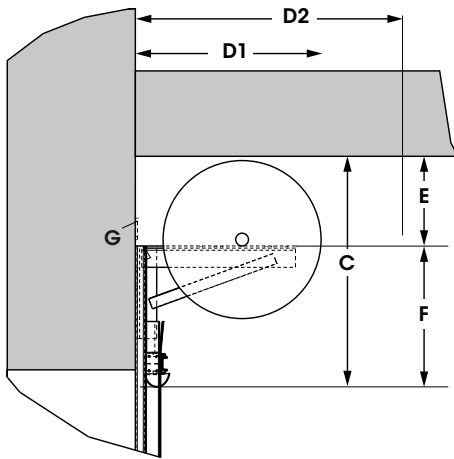

Fig: 1.4.2

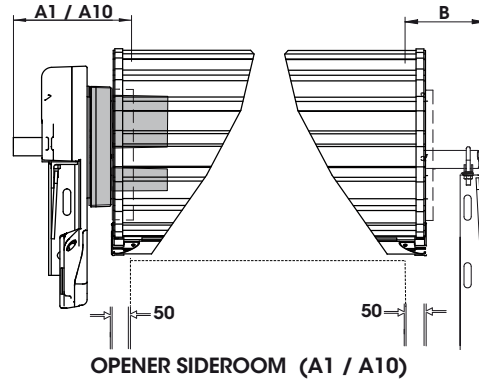

Fig: 1.4.3

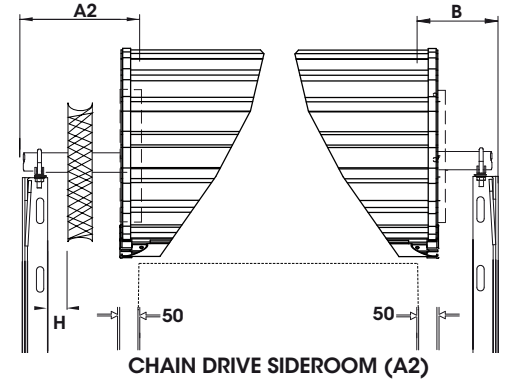

Fig: 1.4.4

dimension panel																
installation	height (mm)	width (mm)	A		B	C	D		E	F	G	H	operation			
			A1* / A10*	A2			D1	D2*								
Recommend	up to 2100	up to 5500 <sup>^</sup>	170 / 275	Opener	N/A	135	535	485	525	260	275	0	0	hand operated		
	2101-2400					135	535	485	525	260	275	0	0			
	2401-2700					135	535	485	525	260	275	0	35			
	2701-3000	up to 3600				185	135	565	525	555	275	290	0	35	chain drive	
	3001-3300						135	565	525	555	275	290	0	35		
	3301-3600						135	565	525	555	275	290	0	35		
Restricted	up to 2100	up to 5500 <sup>^</sup>	170 / 275	Chain	N/A		135	475	485	525	260	215	60	0	hand operated	
	2101-2400						135	475	485	525	260	215	60	0		
	2401-2700						135	475	485	525	260	215	60	35		
	2701-3000	up to 3600				185	135	535	525	555	275	260	30	35	chain drive	
	3001-3300						135	535	525	555	275	260	30	35		
	3301-3600						135	535	525	555	275	260	30	35		
Windlocked	up to 2400	up to 5500 <sup>^</sup>	170 / 275	Opener	N/A		200 / 305	185	535	485	525	260	275	0	0	hand operated
							220 / 325	205	535	485	525	260	275	0	0	
	2401-3000						200 / 305	225	185	565	525	555	275	290	0	35
						220 / 325	245	205	565	525	555	275	290	0	35	

Fig: 1.4.5

NOTE: All measurements are in millimeters ( mm )

Windlocked Steel Substrate      Windlocked Masonry Substrate

\*A1 Based on a Controll-A-Door PowerDrive and GDO-12 Hiro.

\*A10 Based on a GDO-10 Toro (Right Hand Side install). Refer to GDO-10 installation manual for LHS installations.

If an opener is installed there is no H measurement required.

D1 & D2\* are the minimum measurements and optimum backroom clearance required for installation.

NOTE: Wind-Locked doors may need between 55 - 68mm curtain overlap on both sides, depending on the substrate used.

<sup>^</sup> R3F has a maximum width of 5100mm.

NOTE: It is not recommended that doors fitted in restricted headroom be fitted with openers.



## 1.5 parts checklist

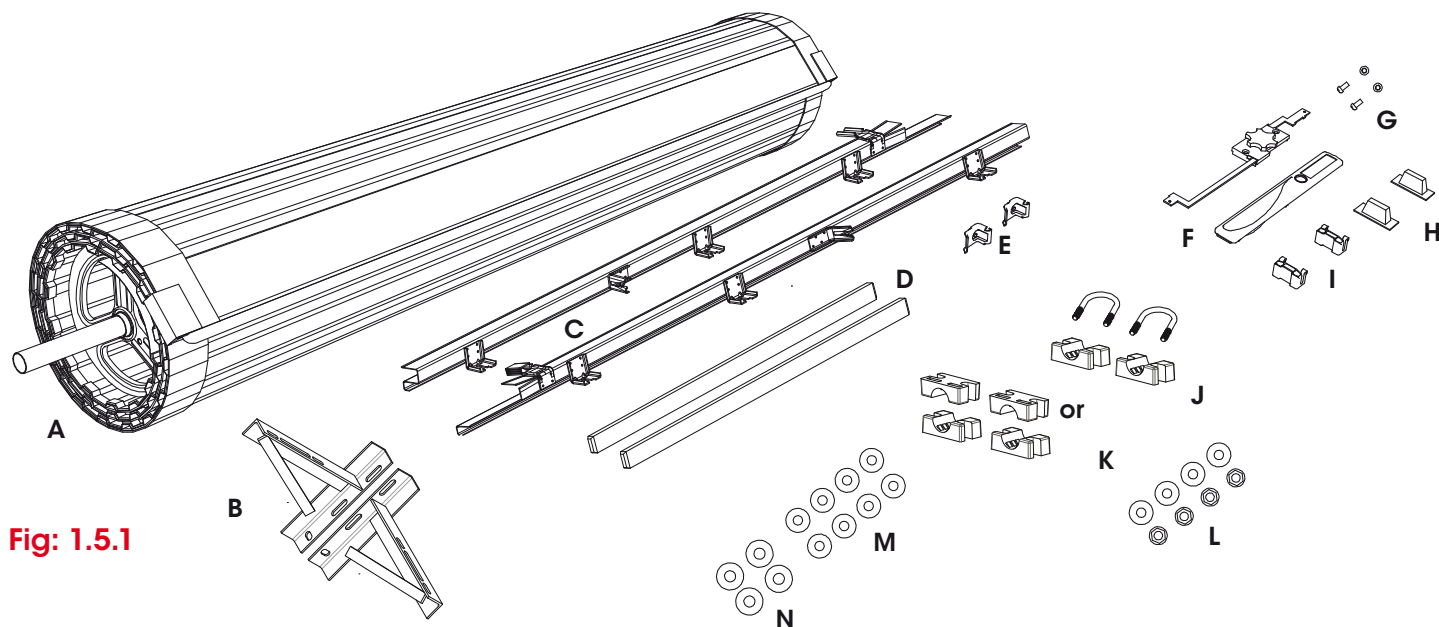

Fig: 1.5.1

SERIES 3 ROLL-A-DOOR		R3F & R3I	R3W	HW
ITEM	DESCRIPTION	QTY	QTY	QTY
A	ROLLED PLASTIC WRAPPED DOOR	1	1	1
B	BRACKETS, LEFT AND RIGHT HANDED	2	2	2
C	DOORS GUIDES LEFT AND RIGHT HANDED	2	2	2
D	STEEL LOCKING BARS	-	2	2
SMALL PARTS BAG CONTAINING				
E	BOTTOM RAIL STOPS AND SCREWS	2	2	2
F	FACEPLATE AND LOCK ASSEMBLY	-	1	1
G	MUSHROOM HEAD SCREWS FOR LOCKING BAR	-	2	2
H	LOCKING BAR COVERS	-	2	2
I	LOCKING BAR RETAINER	-	2	2
J	U-BOLT BRACKET SADDLES	2	2	2
K	CAST SADDLES WITH BOLTS	2	2	2
L	NUTS & WASHERS FOR "U" BOLTS / SADDLES	4	4	4
M	SMALL WASHERS (DOOR SIZE DEPENDENT)	8-12	8-12	8-12
N	LARGE WASHERS	4	4	4

## 1.6 initial calculations

- Measure the opening width of garage.
- Measure the door curtain width.
- Calculate over lap for each side: **door width - opening width ÷ 2 = over lap**
- Mark the line for the edge of door curtain (over lap) on each side of the opening.



- Standard Series 2 doors = 50mm (minimum) overlap each side
- Windlock (HW) Series 2 doors = 55+mm (minimum) overlap each side

## 2.0 installation

### 2.1 install first bracket

dimension panel										
	height (mm)	width (mm)	A		B	C	E	F		
			A1* / A10*	A2						
			Opener	Chain						
Recommend	up to 2100	up to 5500 <sup>^</sup>	170 / 275	N/A	135	535	260	275		
	2101-2400				135	535	260	275		
	2401-2700				135	535	260	275		
	2701-3000				135	565	275	290		
	3001-3300				135	565	275	290		
3301-3600	135	565		275	290					
Restricted	up to 2100	up to 5500 <sup>^</sup>		170 / 275	N/A	135	475	260	215	
	2101-2400					135	475	260	215	
	2401-2700					135	475	260	215	
	2701-3000					135	535	275	260	
	3001-3300		135			535	275	260		
3301-3600	135	535	275	260						
Wind	up to 2400	up to 5500 <sup>^</sup>	170 / 275	N/A	185	535	260	275		
					205	535	260	275		
	2401-3000				200 / 305	225	185	565	275	290
					220 / 325	245	205	565	275	290

Fig: 2.1.1

NOTE: All measurements are in millimeters ( mm )

Windlocking Steel Substrate    Windlocking Masonry Substrate

\*A1 Based on a Controll-A-Door PowerDrive and GDO-12 Hiro.

\*A10 Based on a GDO-10 Toro (Right Hand Side install).

Refer to GDO-10 installation manual for LHS installations.

<sup>^</sup> R3F has a maximum width of 5100mm.

**NOTE: It is not recommended that doors fitted in restricted headroom be fitted with openers.**

- Use above diagrams Fig 2.1.1 and 2.1.2 for head and sideroom clearances.
- Mark three hole positions using slots of the bracket (B).
- Drill holes, then attach bracket using six 10mm (3/8") bolt size masonry anchors; (dynabolts or similar).

**WARNING!** The structure substrate must conform to the DTCM requirements. Refer to [bac.nt.gov.au](http://bac.nt.gov.au) for the [DTCM Manual](#) or [High Wind drawings on the B&D Website](#).

### 2.2 install second bracket

- Using a water level mark the position for the second bracket (Fig 2.2.1)
- Re-check levels then drill and fix as with first bracket.

**CAUTION:** The brackets must be perfectly level for the door to operate.

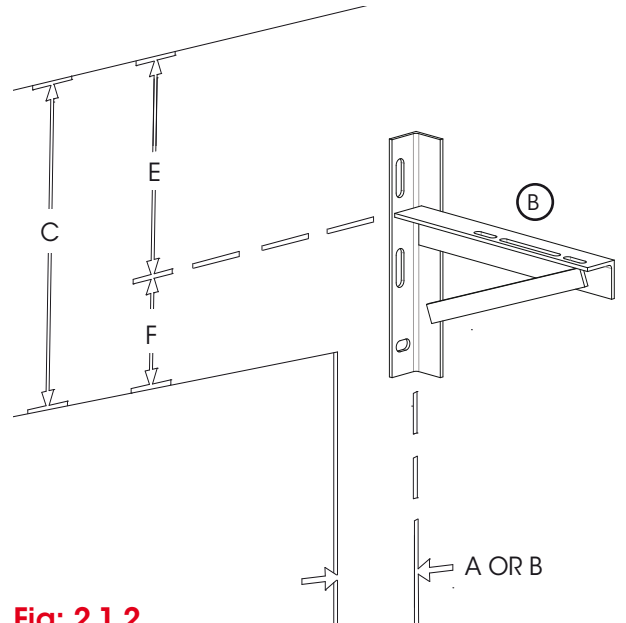

Fig: 2.1.2



**Take note of drive through clearance heights in fig 1.4.2b as the bottom rail will hang into the opening on some doors, therefore reducing the opening.**

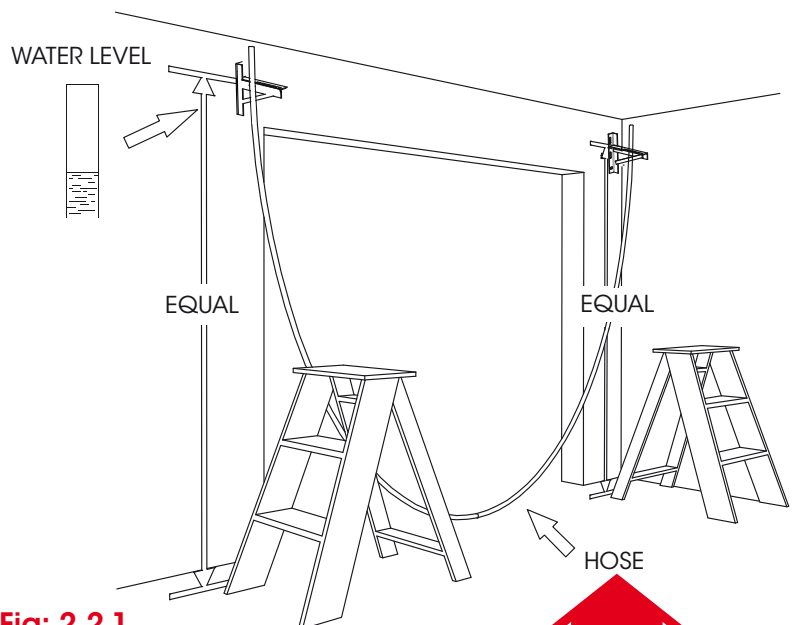

Fig: 2.2.1



### 2.3 place door on brackets



**TWO PERSON LIFT:** this product requires a two person lift to raise onto the brackets. Use proper techniques and equipment to lift the door from the trailer and up onto brackets.



**CAUTION: DO NOT CUT THE PLASTIC WRAP OR PACKAGING YET**

- a) Check the axle length and cut if sideroom is limited. Before cutting, make sure the floating axle is free and centred (**Fig 2.3.1**). Centre will be found by rotating the axle a quarter turn in either direction then releasing. With centre found, make a clear mark on the axle against the hub for later reference.
- b) With the door the correct way round (the curtain rolls down the rear of the opening) carefully lift door onto the brackets using block and tackles attached to the door axles, or other suitable lifting equipment – to avoid curtain damage.
- c) Loosely fit "U" bolt saddle (J) and/or cast saddle (K), or double saddle and position the door so that it overlaps the opening evenly both sides so that the axle is positioned on the bracket arm slots as far forward as possible (**Fig 2.3.2**) Fitting the saddles eliminates the door falling from the brackets.
- d) Centre the door with the opening, while ensuring the floating axle is also centred with the door.

Do this by lining up previous marks with the hub, then lift both the axle and the door together until it is centred with the opening. Rotate both the door and the axle so that the bottom rail is level with the arm of the bracket.

- e) Now tighten the "U" bolts saddle (J), or double saddle (K) (door size dependent), using washers under nuts (L), to a torque of 40 newton metres or 30 ft.lb.

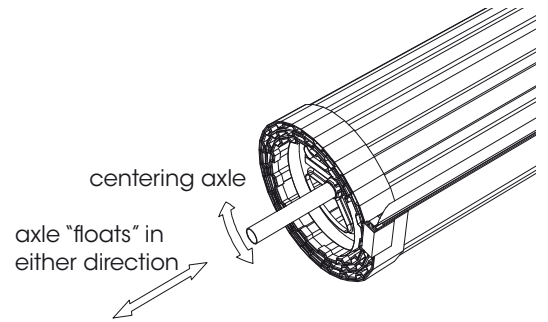

**Fig: 2.3.1**

**doors up to 3000mm high**

**doors up to 3600mm high**

**WARNING!** practice correct lifting techniques and use suitable equipment

**WARNING!** Axle must be securely clamped otherwise door will lose spring tension.

**Fig: 2.3.2**



## 2.4 install guides

### 2.4.1 positioning guides

**WARNING!** Do not grease the guides. Grease will damage the Nylofelt® running strips and make doors heavier to operate.

**CAUTION:** Restricted headroom installation is not recommended for automated doors unless the door is installed lower into the opening. **NOTE:** This will reduce the drive through height.

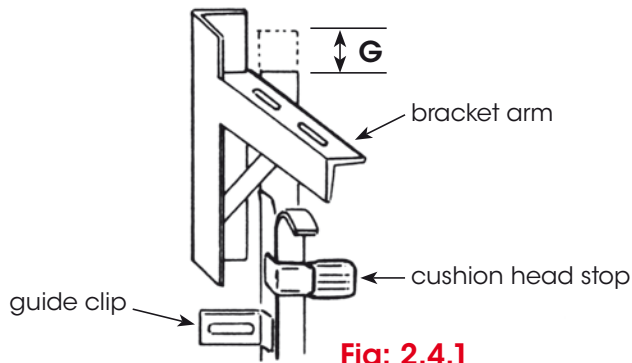

**Fig: 2.4.1**

dimension panel			
	height (mm)	width (mm)	G
Recommend	up to 2100	up to 5500 <sup>^</sup>	0
	2101-2400		0
	2401-2700		0
	2701-3000		0
	3001-3300	up to 3600	0
	3301-3600		0
Restricted	up to 2100	up to 5500 <sup>^</sup>	60
	2101-2400		60
	2401-2700		60
	2701-3000		30
	3001-3300	up to 3600	30
	3301-3600		30
Wind	up to 2400	up to 5500 <sup>^</sup>	0
	2401-3000		0
			0

R3F has a maximum width of 5100mm

**WARNING!** All High Wind installations must adhere to fixing types and centres as referenced in the [DTCM Drawings](#) and [B&D High Wind Drawings](#).

**tip** If securing to uneven brickwork, packers may be required behind clips, to prevent them twisting out of square; also ensure that clips are positioned on secure bricks.

- a) Check that curtain overlaps equally on both sides.
- b) Check that guides © are the correct length, that is, starts level with the brackets (or as per table above at position G). (Fig 2.4.1) If guides need to be shortened cut from bottom of guide.
- c) For Series 3 Doors:
  - (i) Now position one guide over the edge of the door curtain. Mark and drill the top fixed guide clip and secure using correct fixing and washers as per table in **Section 1.2**, allowing 3-4mm clearance between the door and the inside of the guide.
  - (ii) Ensuring guide is plumb, using spirit level, then drill and fix remaining clips and head stop.

For Series 3 Windlock Doors:

- (i) If there is limited sideroom available the guide may need to have the side cut out to accommodate. See **Fig 2.4.2** for recommended and restricted sideroom with a clearance of 2-5mm to the bottom rail roller.
- (ii) Now position one guide over the edge of the door curtain. Mark and drill at top guide hole and secure guide using fixing types as per [High Wind Certification Drawings](#), taking note of the specific spacing requirements.
- (iii) Ensuring guide is plumb, drill and fix remaining holes in guide as per spacing details listed.
- d) With the top of the 2nd guide level with the first, repeat (c) for the specific door type.

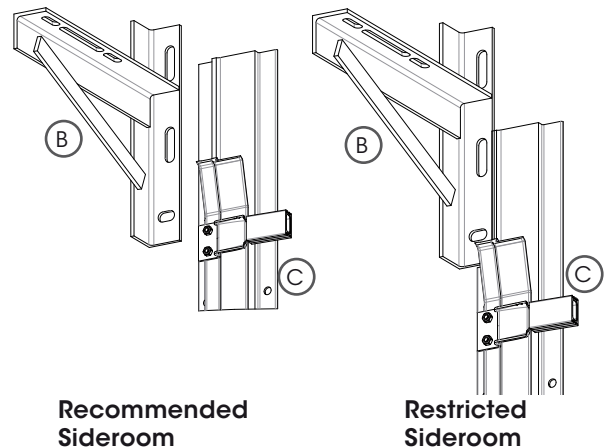

**Fig: 2.4.2**

## 2.5 tension the springs



**WARNING!** Once the packaging containing the door roll is cut, the door will have a strong tendency to rise and revolve. If uncontrolled, the rapidly unrolling door could cause damage or injury.

### 2.5.1 tensioning and adjustments

- a) Ensure that the bottom rail and axle is turned as one to the position shown in **Fig 2.5.1**.
- b) Ensure both "U" bolts are tightened, then -
  1. Rotate the door approximately 2 complete turns in a forward direction to apply tension. Do not let go as the springs are now tensioned. See arrow in **Fig 2.5.1**.
  2. Hold the door firmly, **NOW** cut the plastic wrap along the bottom rail (taking care not to damage door surface).
- c) Pull the curtain down slowly into the guides below the head stop in **Fig 2.5.2**.
- d) Fit bottom rail stops (E) using self locking nuts provided. Allow the door to rise and rest against head stops **Fig 2.5.3**.
- e) Test the door operation by moving it up and down. The curtain must feed in smoothly without bumping.
- f) Reposition the guides as necessary to allow smooth and even operation with clearances shown below throughout. See images in **Fig 2.5.4** for each specific guide / wind region adjust lead in as required Step 2.5.2.

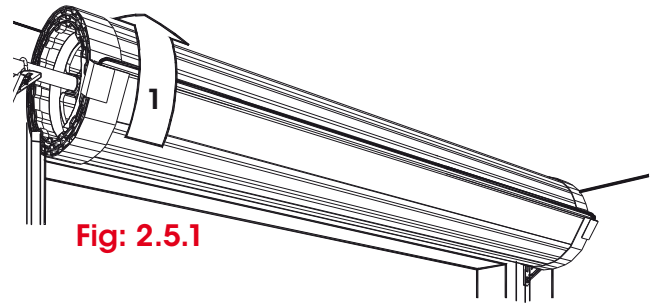

**Fig: 2.5.1**

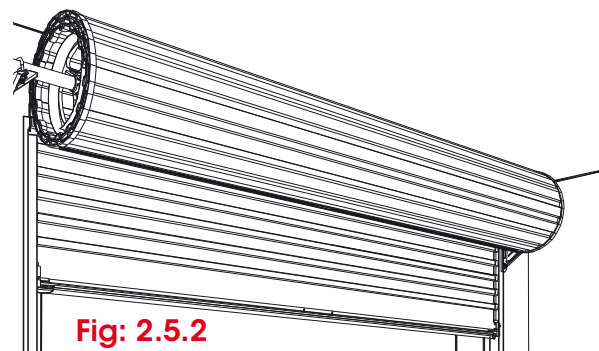

**Fig: 2.5.2**

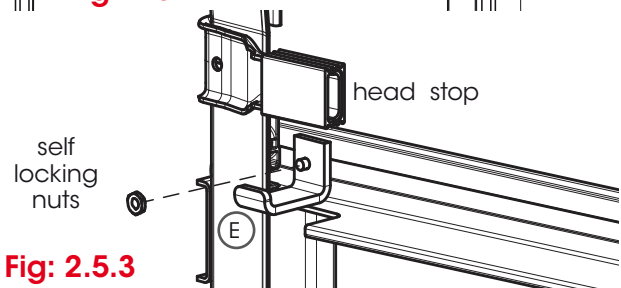

**Fig: 2.5.3**

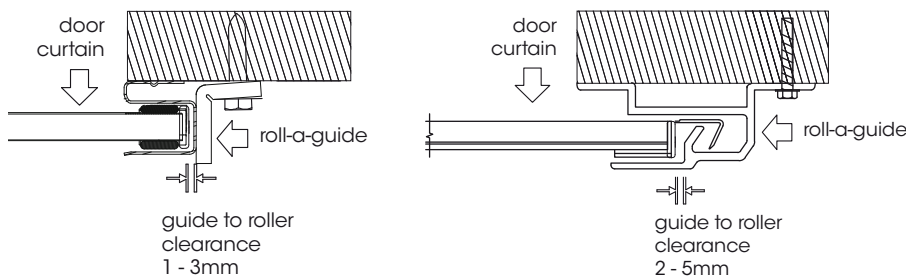

**Standard Guide**

**Windlock Guide (Region C)**

**Fig: 2.5.4**

### 2.5.2 creating proper guide lead-in

The shape of lead-in is critical for successful door operation and trouble free performance. The shape of lead-in needs to be formed by the installer, refer to **(fig 2.5.5)**.

- a) With multigrips, bend top 5mm of lead-in approximately 45° to prevent Nylofelt® catching on lead-in.
- b) Bend lead-in from door stop to top of lead-in (along press cut), to finish 15mm from its original position.
- c) Check top of guide lead-in to ensure that the door does not make contact when rotated. Damage to Nylofelt® could result.

**correct bending of S2 guide lead-in**

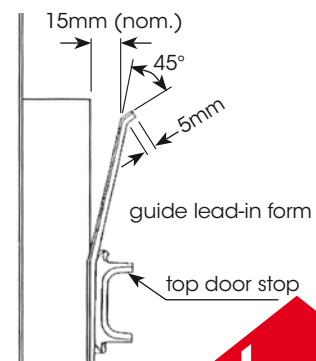

**Fig: 2.5.5**



**Installer may need to increase the 15mm dimension for larger door heights to ensure the smooth operation of the door.**





**WARNING!** For all doors that are fitted with openers. To reduce the risk of damage to persons or property, be sure to cut off any excess thread of the screw that protrudes the weight bottle and file any burrs.

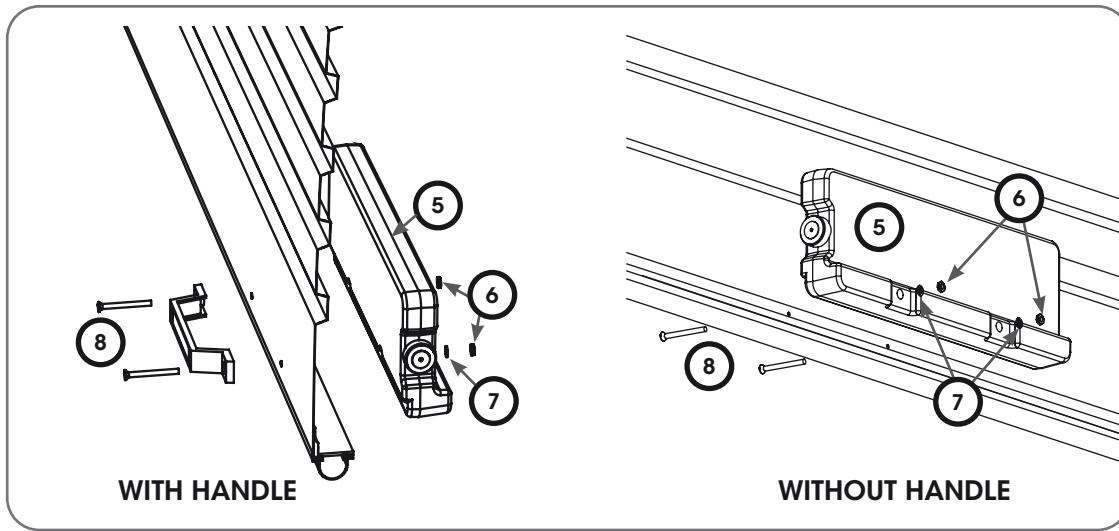

## 2.6 locking

### 2.6.1 centre lift lock (only with R3W & R3F)

- Fit faceplate to outside of door. Fit hooks onto edge of aperture then slide faceplate as far to the right as possible. Use adhesive tape to hold in position Fig 2.6.1.
- Attach the lock body to the faceplate from the inside, using screws supplied. Do not overtighten the screws.
- Pull the curtain down slowly into the guides below the head stop.
- Assemble locking bar to retainer and through plastic edge retainer. Mark the position of lock bar on side of guide. Transfer location mark to inside back face of guide and drill a file slot 10mm wide x 25mm long. Equally spaced on centre line of guide. Allow approximately 5mm clearance from top of slot to top of locking bar.
- Slide bars through guide slot, then back onto lock arms. Screw on securely using 4mm x 6mm screws supplied.
- Fit locking bar covers (H) to cut outs on each side.

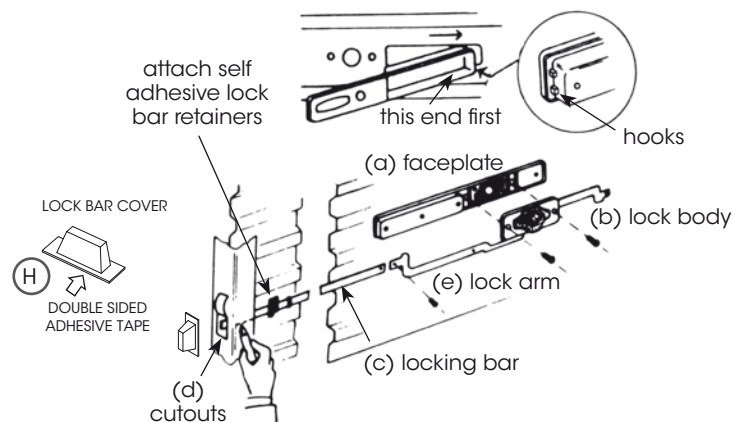

**Fig: 2.6.1**

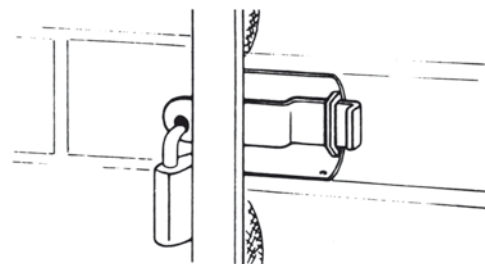

**Fig: 2.6.2**

### 2.6.2 internal waist high slide bolt (R3I)

(left hand side shown - viewed from inside)

With door fully closed check that bolt slides through guide. Adjust hole if necessary.

**2.6.3 high wind centre lift lock (only with R3W & R3F)**

- a) Undo screws to separate lock from faceplate.
- b) Fit faceplate to outside of door. **Fig 2.6.3**. Fit hooks onto curtain edge, then slide faceplate as far to the right as possible. Use adhesive tape to hold in position.
- c) Attach the lock body to the faceplate from the inside, using the mounting screws and washers. Do not over-tighten the screws.
- d) Attach self adhesive lock bar retainers. For additional strength drill 2 x 1/8 holes from inside using retainer as a template and fit 2 x 1/8 pop rivets to each retainer from the face of the door.
- e) With the door in the closed position make the lock hole position in the side guides.
- f) Drill and file out a slot:
  - i) NO PADLOCK - no longer than 32mm and no wider than 10mm as in **Fig 2.6.4a**. Ensure top of the slot remains in line with top of locking bar.
  - ii) WITH PADLOCK - create slot as per i) then, additional 2 holes no smaller than 20mm, positioned central to slot for waist high lock as in **Fig 2.6.4b**.

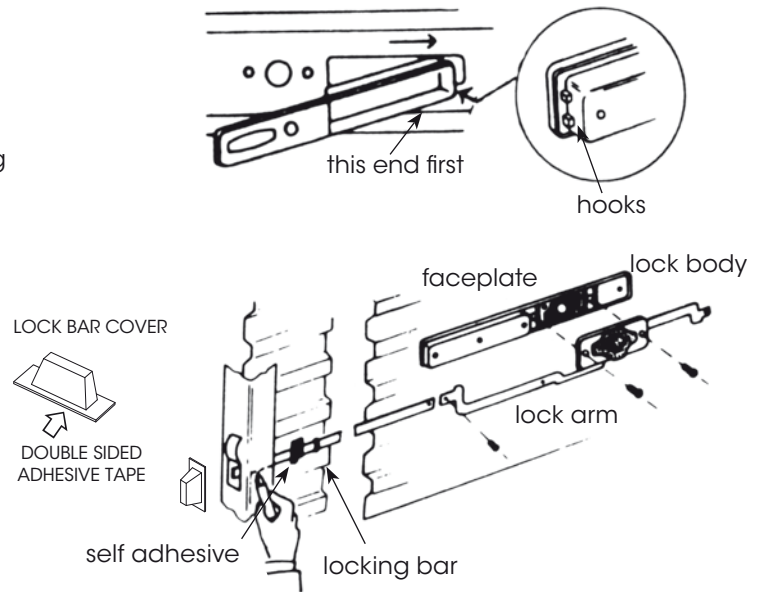

**Fig: 2.6.3**

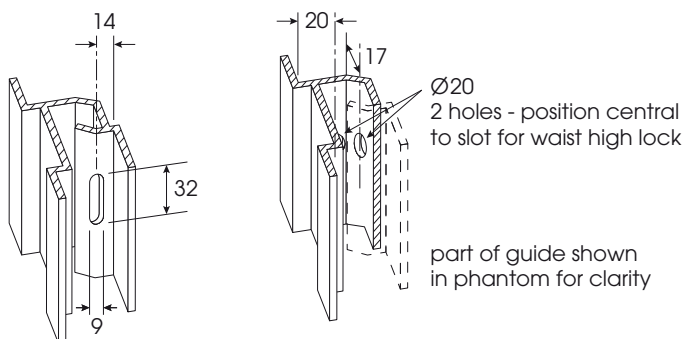

**Fig: 2.6.4a**

**Fig: 2.6.4b**

cut away view of padlock in place

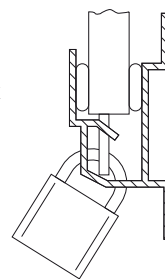

spacer - special shaped to suit aluminium guide profile

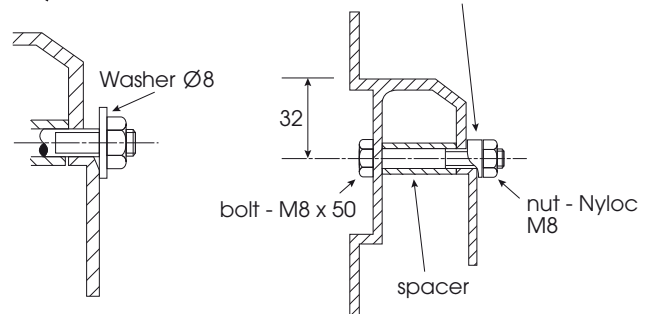

- g) Slide bars through guide slot, then back, onto lock arms. Screw on securely using 4mm x 6mm screws supplied.
- h) For bottom rails with shoot bolt locking refer to Fig 2.6.5.
- a) For fitting optional padbolt type locking, refer to Fig 2.6.6.

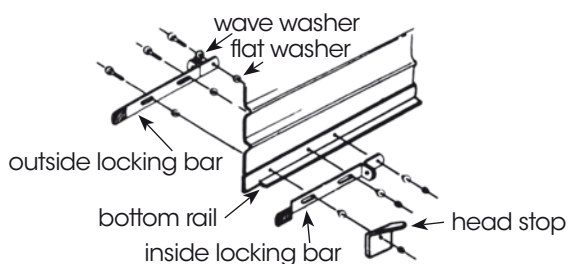

**Fig: 2.6.6**

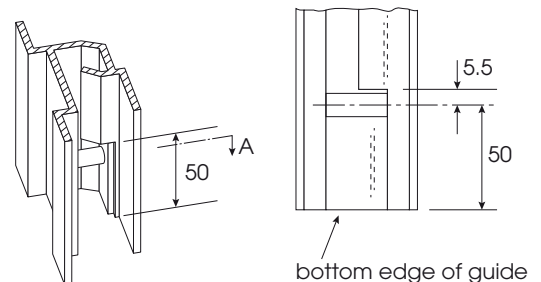

**Fig: 2.6.5**

**NOTE: Please contact your B&D representative for all other lock solutions**



## 2.7 troubleshooting

Symptom	Possible cause	Remedy
Door is hard to operate in ANY DIRECTION	Door jamming in the guides	Check: a) the guide clearances b) the guides are plumb c) that the guide surfaces are clean and free from oil d) that the locking bars are the correct length e) that the weatherseal is correct length
The door is hard to operate in ONE DIRECTION	The spring tension requires adjustment	a) if the door is hard to lift, but tends to drop, refer to step 2.9 to increase the spring tension b) if the door is hard to close, but tends to rise, refer to step 2.9 to decrease the spring tension
If the door rolls up crooked	Brackets are not level	Make sure brackets are level, refer to step 2.2.
	Guides are not plumb	Make sure the guides are plumb, refer to step 2.4.
	Axle is not centred	Centralise the axle, refer to step 2.8.

## 2.8 centralise the axle when door is mounted



**WARNING!** Ensure that pipe wrench is fitted correctly to the axle and if it is gripped onto the axle do not underestimate the tension in the spring when undoing the clamps.



**CAUTION:** THIS ADJUSTMENT REQUIRES 2 PERSONS TO COMPLETE.

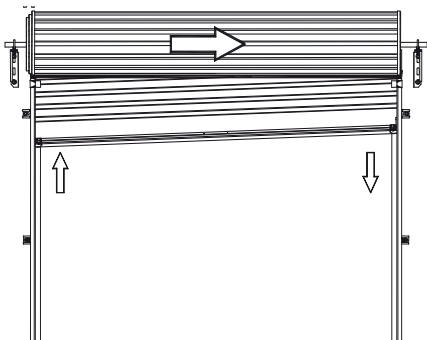

If the door rolls up crooked with the **RIGHT HAND SIDE** higher than the left proceed as follows:

- Roll the door up as high as possible and tie two ropes around the door roll approximately 300mm from each end, as a safety precaution.
- With a person at each end of the door, hold the axle firmly with a large pip wrench (Stillson) at least 450mm long.
- Loosen the "U" bolt nuts at both ends and **KEEP A FIRM GRIP ON WRENCH.**
- Move the axle to the **RIGHT** between 20 - 40mm.
- Re-tighten "U" bolts before releasing pipe wrench.
- Test and repeat if further adjustment in needed.
- If the door is stiff to work or rattles over lead-in on top of guide, then refer to Step 2.4.

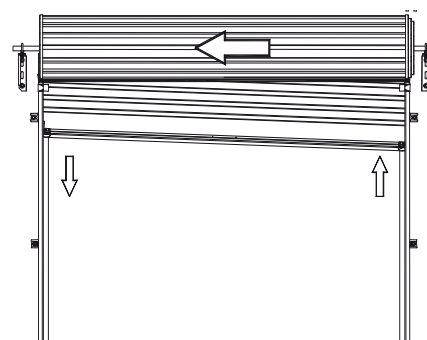

If the door rolls up crooked with the **LEFT HAND SIDE** higher than the left proceed as follows:

- Roll the door up as high as possible and tie two ropes around the door roll approximately 300mm from each end, as a safety precaution.
- With a person at each end of the door, hold the axle firmly with a large pip wrench (Stillson) at least 450mm long.
- Loosen the "U" bolt nuts at both ends and **KEEP A FIRM GRIP ON WRENCH.**
- Move the axle to the **LEFT** between 20 - 40mm.
- Re-tighten "U" bolts before releasing pipe wrench.
- Test and repeat if further adjustment in needed.
- If the door is stiff to work or rattles over lead-in on top of guide, then refer to Step 2.4.

## 2.9 adjusting spring tension

**WARNING!** Ensure that pipe wrench is fitted correctly to the axle and if it is gripped onto the axle do not underestimate the tension in the spring when undoing the clamps.

**CAUTION:** THIS ADJUSTMENT REQUIRES 2 PERSONS TO COMPLETE.

- With the door rolled up tie two ropes around the door roll approximately 300mm from each end, as a safety precaution.
- With a person at each end of the door, hold the axle firmly with a large pipe wrench (Stillson) at least 450mm long.
- Loosen the "U" bolt nuts at both ends and **KEEP A FIRM GRIP ON WRENCH.**
- Rotate the axle in the required direction (**Fig 2.9.1**).
- Re-tighten the "U" bolts to a tension of 40 Newton metres or 30 ft.lbs **BEFORE** releasing pipe wrench.
- Test and repeat if further adjustment is necessary.

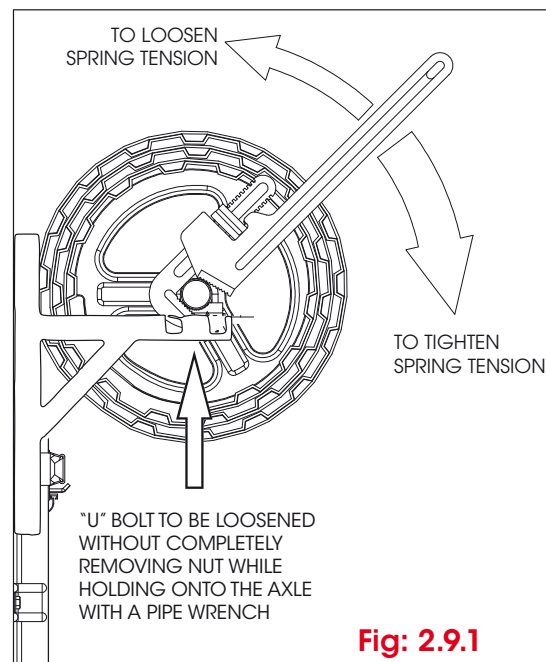

**Fig: 2.9.1**

## 3.0 appendix

### 3.1 after installation care

#### cleaning

**COLORBOND® and coloured steel FINISH DOORS:** Your B&D Roll-A-Door® door has been pre-painted with a high durability polyester paint system especially designed and tested for the harsh Australian conditions. However, all exposed surfaces require some attention to guard against the premature onset of corrosion and any other harmful atmospheric effects. In our atmosphere there are harmful deposits that gather on the door surface and if not removed regularly, will seriously affect the appearance and life of the door.

Washing of the door with clean water and a cloth every 14 days is recommended – particular care should be taken to clean areas of the door not normally washed by rain, including the top of the door roll inside the garage.

**NOTE:** In locations where there is likely to be salt in the air or industrial fallout is severe, more frequent washing is advisable and additional protection of the surface maybe required.

Touch-up paint, if required, is available from your B&D dealer.

#### lock

Your lock does not require special maintenance, however, if the keyway becomes stiff, the application of powdered graphite is recommended – do not grease or oil the lock. The faceplate should be washed with soapy water and rinsed well. Strong solvents, such as acetone, should not be used – these will damage the surface. **WARNING!** Do not disassemble the lock mechanism.

When opening the door, always make sure the key is with drawn from the lock – if this is not done, the lock mechanism could be damaged and the key bent or broken.

We suggest you record your full Key letter and Number on the front of this manual and if replacement keys are required they can be obtained from your nearest B&D office, simply by quoting this number. If the keys have been lost and the number not recorded, it can be found stamped into the locking arm at the back of the mechanism.

#### NYLOFELT®

On no account should you use grease or oil in the door guides or on the Nylofelt® running strips – the grease or oil will clog the Nylofelt® and spoil the operation of the door. An occasional wipe with a cloth dampened with mineral turps or methylated spirits, down the inside of each guide, is very beneficial in removing any trace of grease or dirt.

After the guides have been cleaned, a silicon spray may be used in the guides.

**NOTE:** WD40 or similar oil based sprays are not silicon and should not be used.

Care should be taken not to damage the Nylofelt®, however, if Nylofelt® is cut or damaged, a lighted match should be used to quickly seal the ends of the nylon braiding, so as to stop any further deterioration.

#### regular maintenance required

B&D recommends that you check the operation of your Roll-A-Door® at least every six months (more regularly in extreme environments or frequent use). The effort required to manually open and to manually close the door should be about the same (if door has an automatic opener, put into manual mode before testing door). If the door is difficult to operate in either direction (up or down) then check:

- 1) that the Nylofelt® running strips on each side of the door have not slipped from the edge and are jamming the door;
- 2) that the door is running correctly in the guides and the guides are straight and perpendicular; and
- 3) that the inside surfaces of the guides are clean and free of obstructions. (see paragraph on care of Nylofelt®)

If you have checked these (and corrected where necessary) and the door is still difficult to operate, then your door will need a service to adjust the spring tension and possibly other operational parts of the door. This service should only be carried out by an experienced door technician, using the correct tools.

If you have an automatic opener fitted to your door, it is particularly important that you ensure the optimum operation of the door, otherwise you may reduce the effective life of the opener.

To keep your door running well, it is recommended that your door be serviced, by an experienced door technician, every 12 months (more regularly in extreme environments or frequent use), or earlier if required.

#### spring tension

It is natural for springs to lose tension over time. When spring tension is adjusted or when your door is first installed it is usual to apply a little more tension than is required for balanced operation, to allow for the normal "settling in" of the springs.

#### warranty

Warranty conditional on proper care as recommended above. Full details of the warranty are available from your nearest B&D office or visit the B&D website [www.bnd.com.au](http://www.bnd.com.au)

#### b&d doors office locations

<b>Head Office</b>	6-8 Fiveways Blvd, Keysborough 3073	Phone (03) 9791 2000
<b>New South Wales</b>	34 Marigold St, Revesby 2212	Phone (02) 9722 5555
<b>Queensland</b>	17 Oasis Court, Clontarf 4019	Phone (07) 3883 0200
<b>Victoria</b>	147-153 Canterbury Rd, Kilsyth 3137	Phone (03) 9237 7766
<b>South Australia</b>	23 Frederick Rd, Royal Park 5014	Phone (08) 8440 4747
<b>Western Australia</b>	96 Mulgool Rd, Malaga 6090	Phone (08) 9247 8777
<b>International/Export</b>	34 Marigold St, Revesby 2212	Phone +61 (0)2 9722 5555

your representative is

Prefixed trademarks are the property of B&D Australia Pty Ltd. B&D Doors & Openers is a division of B&D Australia Pty Ltd. ABN 25 010 473 971. © 2018 B&D Australia Pty Ltd.

[www.bnd.com.au](http://www.bnd.com.au)

**b&d**