

The logo consists of the lowercase letters 'b&d' in a white, sans-serif font, centered within a black diamond shape.

Panelift[®]

Storm-Shield[™] PFI

installation instructions

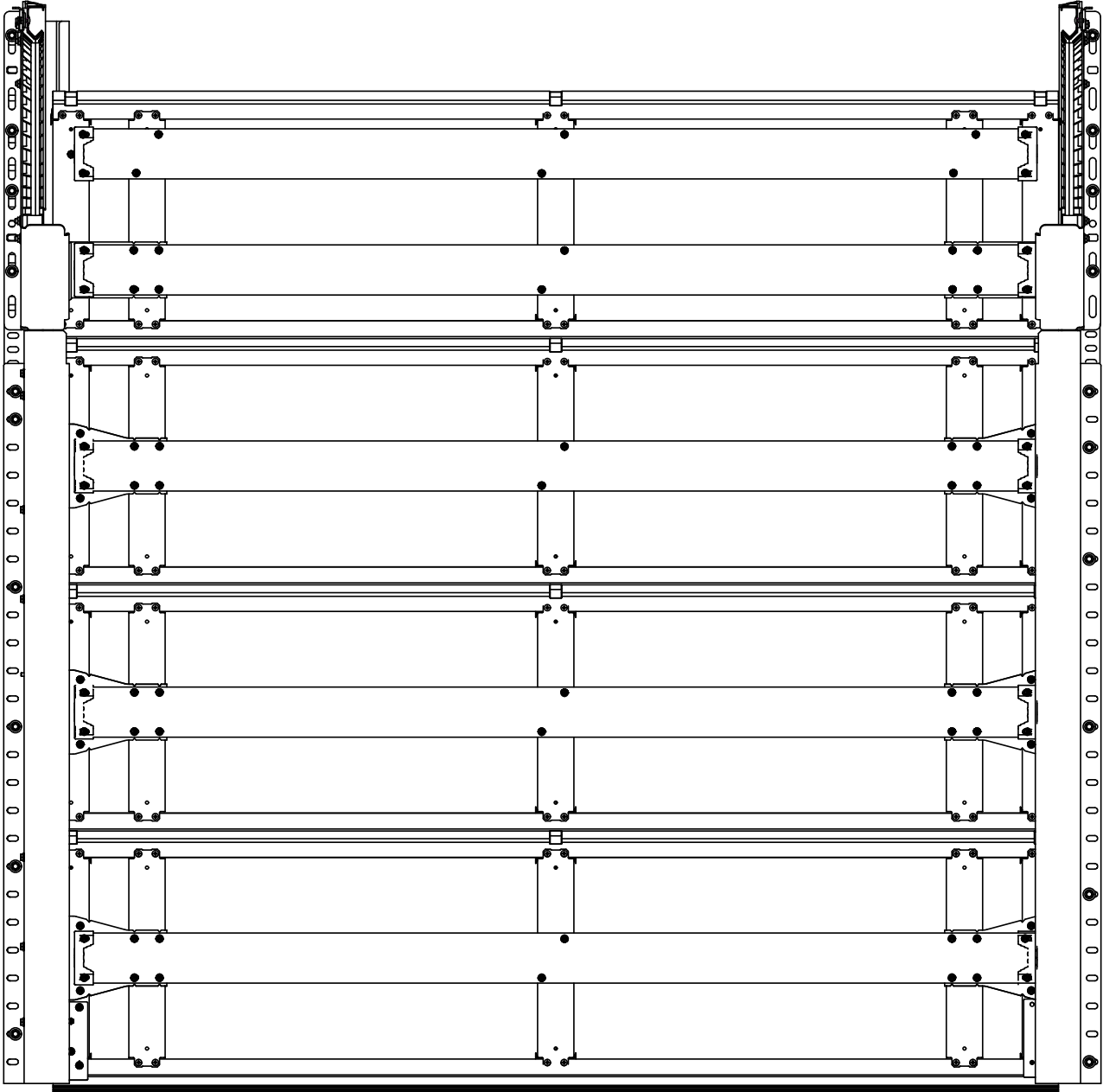

These instructions are intended for professional garage door installers. All references are taken from inside looking out.

DOC# 165024_02
RELEASED: 19/09/23

www.bnd.com.au

The logo consists of the lowercase letters 'b&d' in a white, sans-serif font, centered within a black diamond shape.

contents

1.0 before you begin	3
1.1 installation safety warnings	3
1.2 fastener recommendations for fitting Storm-Shield™ doors	4
1.3 parts checklist	5
1.4 requirements before installation	6
1.5 tools	6
1.6 check & mark out the opening	7
2.0 assembly	8
2.1 assembling vertical tracks	8
2.2 door panels	9
2.3 fitting reinforcing & end hooks to bottom & middle panel	10
3.0 installation	11
3.1 installing vertical tracks	11
3.2 adding panels	12
3.3 installing horizontal tracks	13
3.4 standard spring counterbalance system	14
3.5 install torsion bar	15
3.6 adding tension to spring	16
3.7 fitting reinforcing to the top panel	17
3.8 fitting tracklocks	18
3.9 final checks	19
4.0 troubleshooting	20
5.0 appendix	22
5.1 hinged tapers	22
5.2 two piece shafts for large doors	23
5.3 after installation care	24

1.0 before you begin

1.1 installation safety warnings

This B&D Door is designed and tested to provide security, attractive appearance and smooth , low effort operation provided it is installed and operated in strict accordance with the following safety warnings. Failure to comply with the following instructions may result in death, serious personal injury or property damage.

NOTE: No guarantee will be given or responsibility accepted by the manufacturers if the door is not installed as instructed.



WARNING!

Crush injury from unsecured door

Tension Springs

- Place a 2 metre exclusion zone around area under the garage opening while installing door. If sufficient area is not available DO NOT install door.
- Follow the installation instructions.
- Ensure correctly fitting winding bar is used.
- Ensure the correct length winding bar is utilised.
- Ensure winding bar is placed appropriately in the torsion socket plug.
- Ensure correct bolts are tightened or loosened (or clamp pliers) to ensure there is no release or controlled release of energy from the spring either through the torsion bar or the winding bar.
- Keep hands clear of the torsion plug at all times.
- Keep head clear of the tensioning bar at all times.



ELECTROCUTION!

- Check risk assessment for any highlighted electrical power concerns.
- Ensure power source is isolated prior to commencement of job.
- Turn off electricity to site when necessary.
- Ensure you check the substrate for electrical wiring prior to penetration.
- Wear rubber soled footwear.



LACERATION:

- Wear appropriate PPE (Dyneema cut off gloves) and keep hands well clear of pinch points.
- Follow instructions explicitly, particularly for the installation of some parts of the panel doors, as the unrolled cut out edges presents a very sharp edge.



CAUTION:

Muscular strain

Fall from ladder

Hand Tools

Entanglement

- Practice correct lifting techniques when required.
- Use mechanical aids such as lifting devices, forklift and cranes where possible.
- Avoid twisting.
- Ensure ladder is the correct type for job.
- Ensure ladder is on flat firm ground that will take the weight without the legs sinking.
- Ensure user has 3 points of contact while on ladder.
- Wear appropriate PPE and utilise operators manual of all tools.
- Use appropriate noise/hearing protection in the form of ear plugs or ear muffs.
- Ensure appropriate fire protection available and housekeeping to ensure that flammable liquids or materials are removed from the area of work.
- Keep hands and loose clothing clear of moving door and guides at all times.
- Depending on the size of the door, this product may requires a two person lift. Use proper techniques and equipment to lift the door from the trailer and into position.



TWO PERSON LIFT:

1.2 fastener recommendations for fitting Storm-Shield™ doors

Storm-Shield™ PFI in accordance with NT Deemed to Comply Manual (DTCM)							
All tek screws to be of a Climaseal® 4 coating finish or equivalent							
substrate type	fastener required	washer required	material thickness (t) mm	grade	yield strength	tensile strength	spacing (mm)
structural steel abutment post	hexhead tek screw 14g - 20tpi x 300mm centres	1.6mm thick 019 O.D Galv. washer	n/a				
corefilled reinforced blk wall	M8 flange head masonry screws or equivalent at 200mm centres	2mm thick 022 O.D Galv washer	n/a				
	galv. M10 ramset ankascrews or equivalent at 400mm centres	2mm thick 022 O.D Galv washer	n/a				
cold formed steel supports	hexhead tek screw 14g - 20tpi centres as per material thickness	1.6mm thick 019 O.D Galv. washer	1mm	G550	550MPa	550MPa	125mm
			1.2mm	G500	500MPa	520MPa	150mm
			1.5mm	G450	450MPa	480MPa	200mm
			1.9mm	G450	450MPa	480MPa	250mm

important notes

1. For Storm-Shield™ PFI doors ensure you are complying to the latest compliance details.
2. For installation to substrate materials not covered in the above chart, the installer should seek expert advice.
3. Substitute fasteners are not recommend unless approved.
5. The above chart specifies the fasteners for new substrate materials only. Seek specialist advice regarding pre-existing substrate materials.
6. It is important that correct washer and plug is used and the correct pilot hole drilled where specified.



WARNING!

The installer must select and use fasteners appropriate to the material into which they are being fixed. For B&D Storm-Shield™ PFI doors ensure you are complying to the latest high wind compliant details. To download the latest drawings visit the B&D website at www.bnd.com.au

1.3 parts checklist

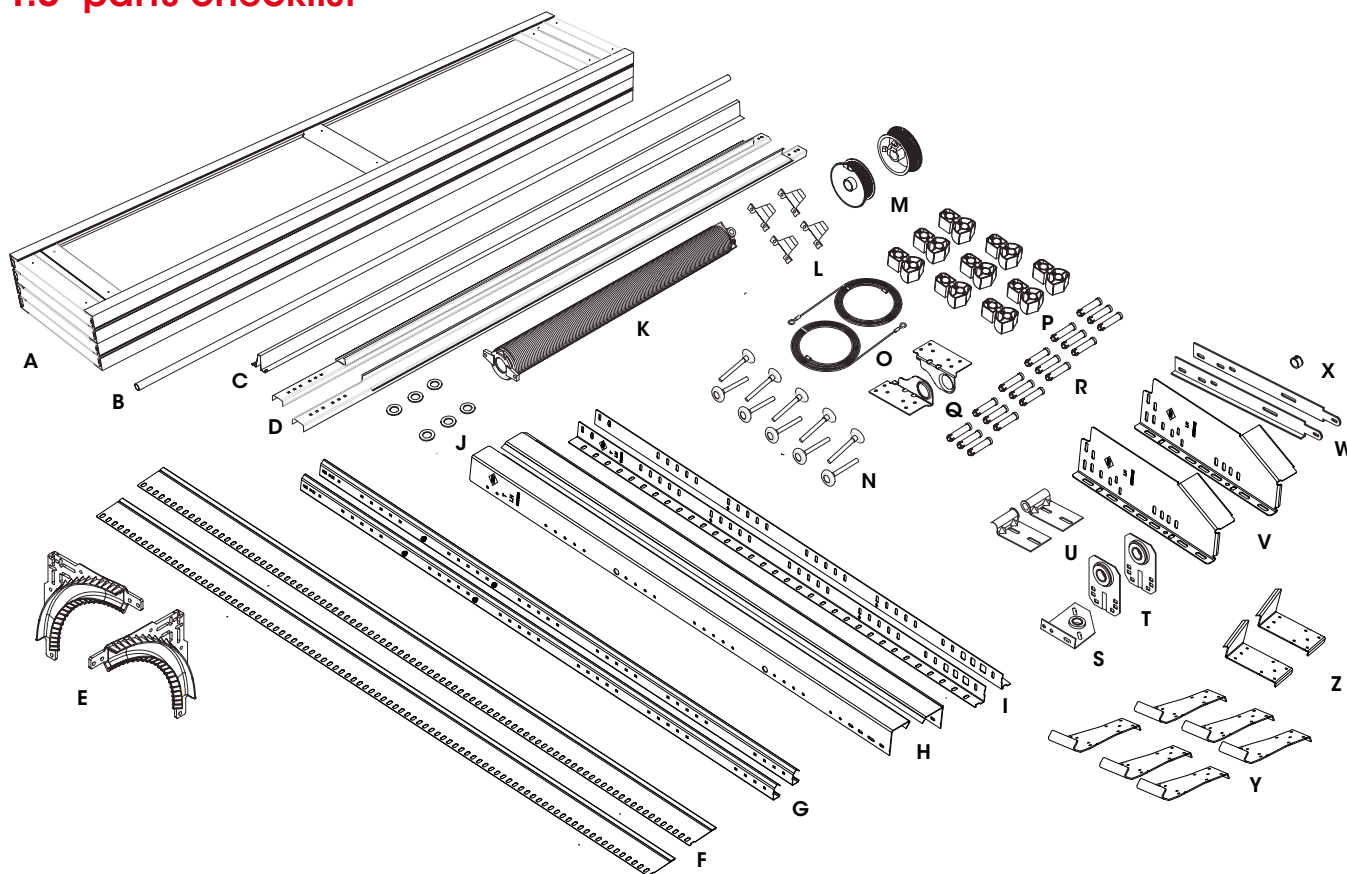

STORMSHIELD SECTIONAL DOOR		
ITEM	DESCRIPTION	QTY
A	DOOR PANELS PACKAGE	1
B	TORSION BAR (TUBE OR SOLID)	1
C	PANEL REINFORCING	5+
D	HORIZONTAL TRACK	2
E	POLYPROPYLENE CURVE	2
F	JAMB SPACER	2
G	VERTICAL STRAIGHT TRACK	2
H	TRACKLOCK BRACKET	2
I	LONG JAMB BRACKET	2
J	WASHERS	6+
K	TENSION SPRING	1-4
L	REINFORCING END CAPS	10+
M	CABLE DRUMS	2

STORMSHIELD SECTIONAL DOOR		
ITEM	DESCRIPTION	QTY
N	WHEEL AXLES	10+
O	BOTTOM HANGER	2
P	LIFTING CABLE	2
Q	HINGE LINKS	12+
R	HINGE PINS	24+
S	SPRING ANCHOR BRACKET	1
T	SIDE BEARING BRACKET	2
U	TOP HANGER	2
V	SHORT TOP TRACK ANGLE	2
W	HORIZONTAL BRACKET	2
X	SHAFT COLLAR	1
Y	REO HOOK BRACKET	6+
Z	TOP PANEL REO HOOK BRACKET	2

reo assignment

	panel count	width ranges (from - to, mm) 1800 - 5500
B&D Storm-Shield™ PFI	4	1 REO to all panels except the top which has 2
	5	
	6	



1.4 requirements before installation

mounting - The door is designed to be mounted behind the opening.

obstructions - Ensure that the surface where the door will be fitted is flush and smooth, and the area behind the opening is free from any protrusions.

structural suitability - Ensure the opening is strong enough to support the door. If unsure, consult a builder.

NOTE: It is builders responsibility to ensure the opening structure complies with the DTCM requirements.

level and plumb - The door must be installed in an absolutely level position, if opening is not level and square, appearance and/or sideroom requirements will be affected. The floor should be level or recessed across the opening to avoid gaps.

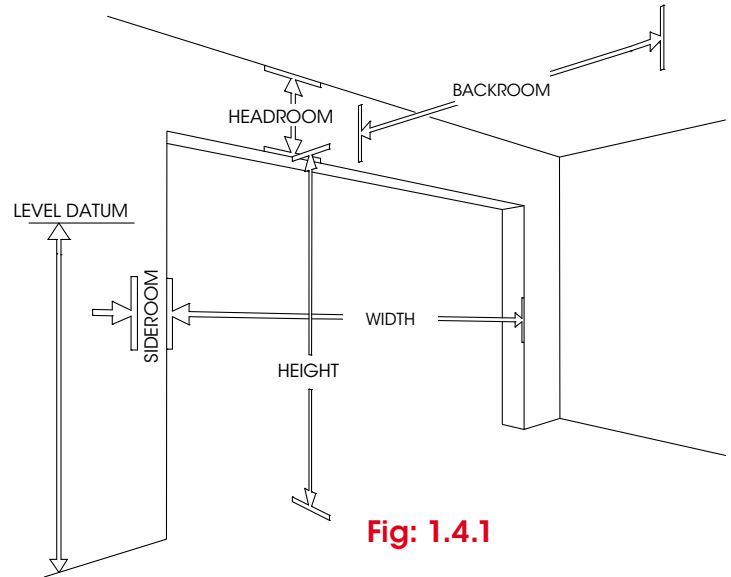

Fig: 1.4.1

1.4.1 measurements

opening width - As the door overlaps each side by 30mm or more, the door should be 60mm wider than the opening. A wider door can be fitted as long as additional sideroom and fixing is available. (Fig 1.4.1)

opening height - The door will fit any opening height up to the marked door size.

sideroom - A minimum of 120mm of sideroom is required over and above door width and should extend above the head to allow for bracket fixing. (Fig 1.4.2 for rear torsion)

CAUTION: 6 panel high doors over 6000mm wide and 7 panel high doors over 5000mm wide require 5-18 cable drums.

headroom - A minimum of 250mm is required. Refer to Fig 1.4.2 for extra measurements.

backroom - as the door extends into the garage when opening refer to Fig 1.4.2 for measurements.

level datum - use a water or laser level to mark a datum line on both sides approx. 1.5m from the floor. Use this line to compare the distance on each side to the opening height to determine if the opening is plumb.

Measurement	Cable drums		
	4-8 & 4-13		5-18
headroom	end bearing brackets	combo brackets	end bearing brackets
FTS = front torsion small curve	250mm	270mm	290mm
FTL = front torsion large curve	290mm	310mm	330mm

backroom	recommend	minimum	
Panel height +	350mm	100mm	
Automated doors rail + opener	doors up to 2400 high	doors up to 3000 high	doors up to 3990 high
backroom	3374mm	4164mm	4954mm
headroom (min)	57mm	57mm	57mm

Fig: 1.4.2

1.5 tools

It is recommended that this door is installed by a professional door installer using a professional and specialised tool kit.



1.6 check & mark out the opening

- Using a water or lazer level, mark both sides approx. 1.5m from the floor.
- Mark equal overlap at each side based on panel width.

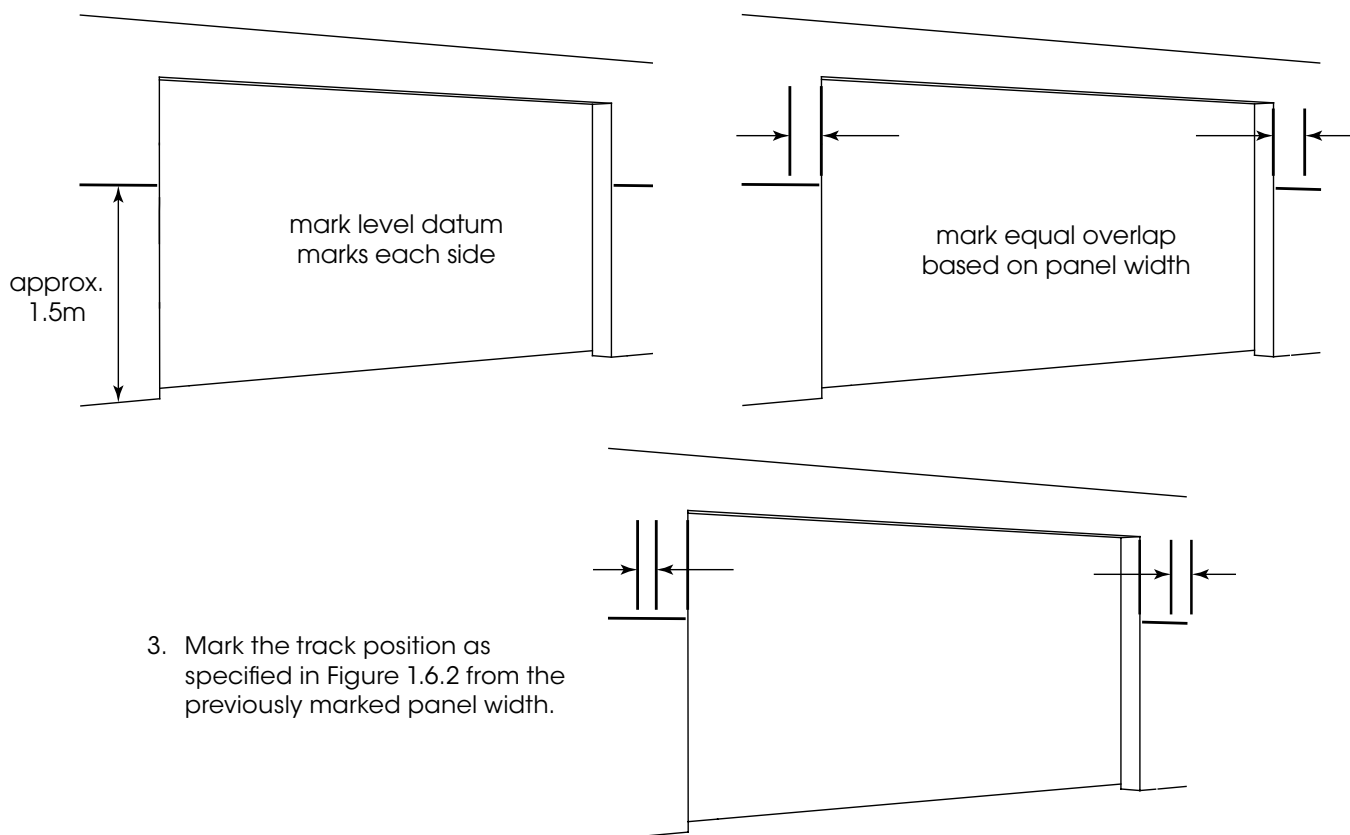

- Mark the track position as specified in Figure 1.6.2 from the previously marked panel width.

Figure 1.6.1 wheel-axle

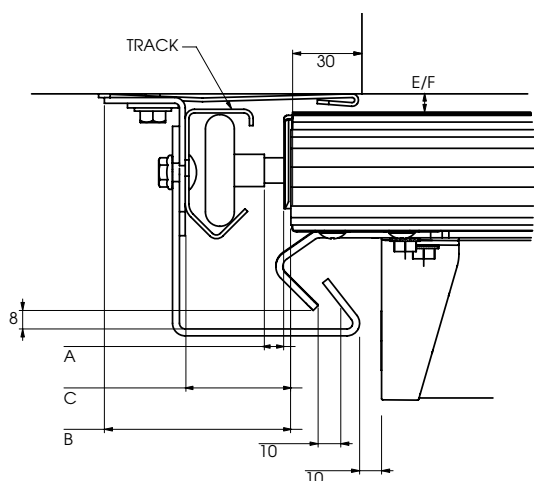

B&D Storm-Shield™ PFI with tracklock positioning

Figure 1.6.2

detail	A at bottom axle	B	C	D	E/F (ref pg 11)
B&D Storm-Shield™ PFI (single wheel)	5mm	90mm	50mm	n/a	17/12mm
NOTE: These measurements allow for final adjustment.					

2.0 assembly

The vertical tracks (G) must be cut as a pair, the cut height should be door height minus:

large curves less 190mm
small curves less 170mm

Long jamb brackets (I) are marked with a 'T' indicating top, do not cut from this end. The jamb spacer (F) is cut to the full height of the assembled track with top track bracket fitted make sure they are cut left and right and from the bottom. Tracklock (H) are also marked with a "T" indicating the top. Tracklock cutting and fitting is shown in Section 3.8.

assembled FTL large curve sample with jamb bracket and spacer shown in position.

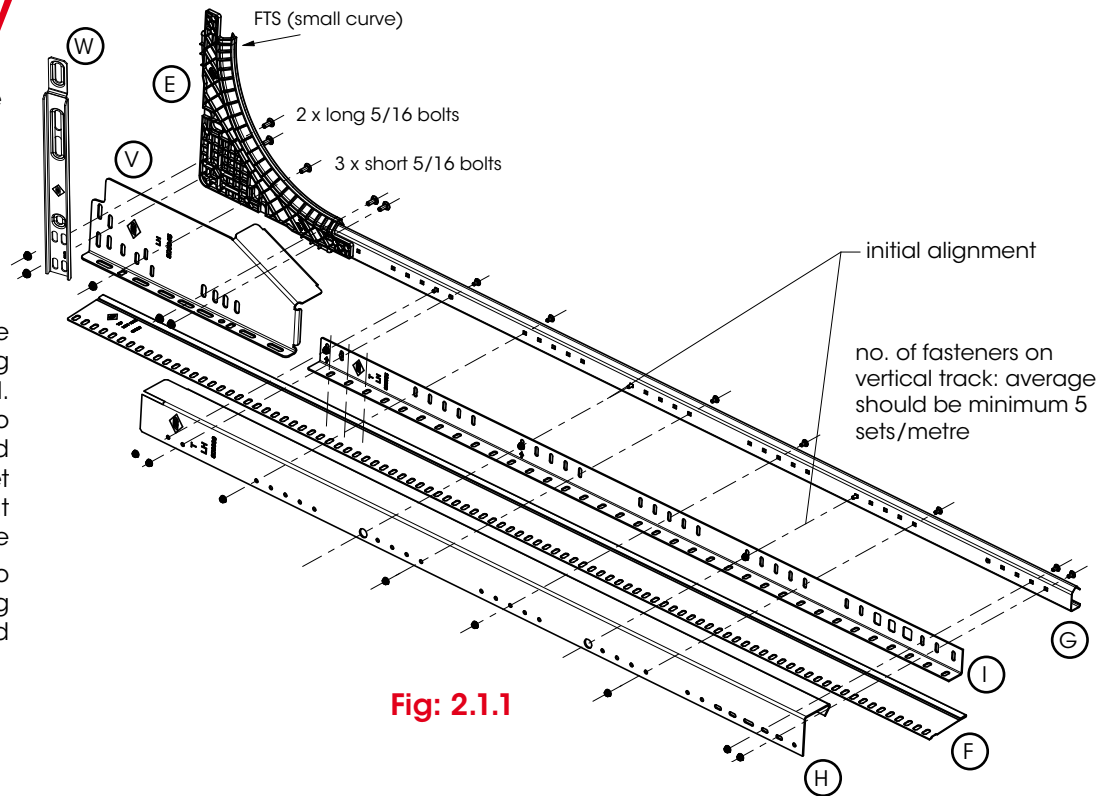
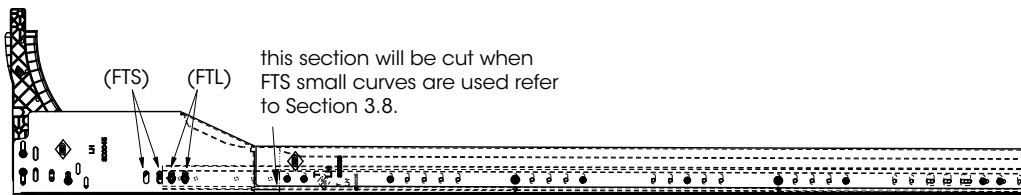

Fig: 2.1.1

2.1 assembling vertical tracks

- First loosely attach the polypropylene curve (E) to the short top track bracket (V) and horizontal bracket (W) using 2 long and 3 short 5/16 flat head bolts and nuts for each assembly as shown in Fig: 2.1.1.
- The small curves will align with the upper slots at the bottom and large curves with the lower of the four slots, repeat for the opposite side.
- Attach the vertical tracks (G) ensuring the cut end is at the bottom use 2 x 5/16 flat head bolts and wiz nuts to each ensuring the ends fit snugly into the polypropylene curves
- Now attach the long jamb brackets (I) to each vertical track (G), only attach with 2 x 1/4 dome head bolts and wiz nuts as shown in the initial alignment holes, these will align with the larger holes in the tracklock (H) when fitting later.
- The track assembly is placed on top of the jamb spacer (F) as it is mounted to the wall. The fixing points should be spaced at 300-400mm centres.



To hold the jamb spacer (F) in place prior to fitting the assembly to the wall fit a 1/4 bolt and wiz nut (dome head to the wall) to the top this will allow it to hang in place whilst fastening to the structure.

2.2 door panels

NOTE: Refer to appendix if installing a taper.

- a) Open up the pack of door panels, making sure the bottom panel (weather strip seal on the bottom of the panel and bottom hinge hole) is on top of the pack. Start with the bottom panel.
- b) Insert each lifting cable (Q), through the holes of the left and right bottom hangers (R) Fig 2.2.1.

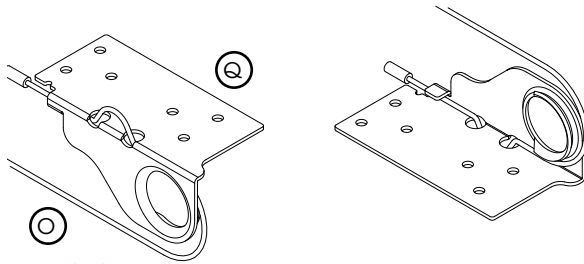

Fig: 2.2.1

CAUTION: DO NOT hold cable in place by squeezing the bracket around it as this will cause the cable to fracture and break.

tip Should you need to temporarily hold the cable in place during installation, before spring tension is applied, only secure with stick tape.

- a) Insert the polyethylene hinge links (P) into the recesses of the top of the panel and fix into place using the white hinge pins (R). Fig 2.2.4.
- b) Insert 4 x the appropriate wheel axle (N) (standard, extended or smooth track) into the top and bottom of the panel.

tip There is a link for every point where there is a stile.

- c) Repeat the process for fitting links, pins and wheel axles to the top of each middle panel.

NOTE: The top panel can be easily identified by always having a centre stile for use with an opener and no hinge link cut outs in the curved top edge.

- d) Once you have finished assembling the middle panels, fit the PFI Seal to the top panel as shown

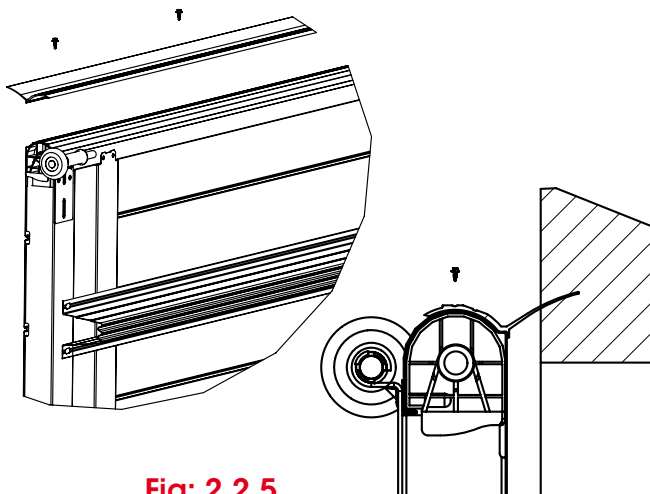

Fig: 2.2.5

- c) Remove existing screws in the two bottom corners of the bottom panel near the weather strip and discard.

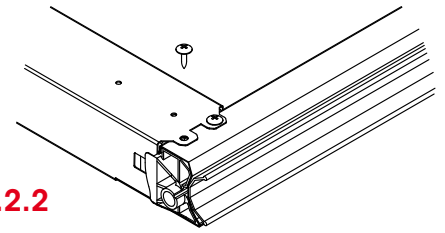

Fig: 2.2.2

- d) Attach the left and right bottom hangers to the lower end of the door using 6 x TEK screws in each.

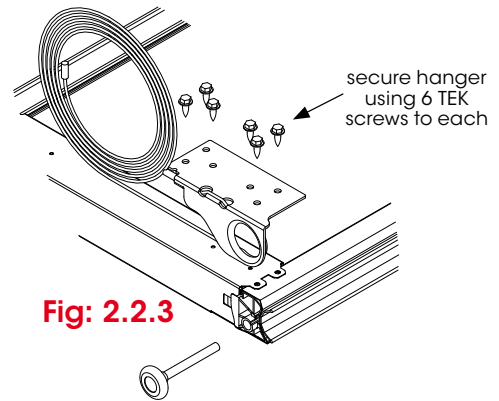

Fig: 2.2.3

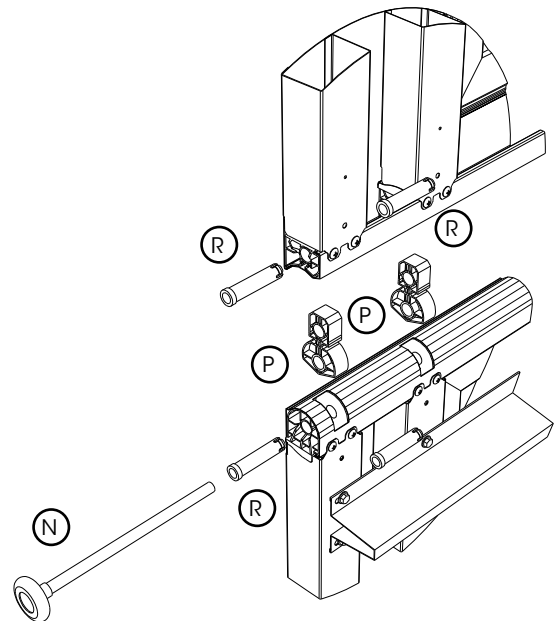

Fig: 2.2.4

double enstile door

in Fig 2.2.5 or alternatively fit the seal to the lintel. The fixing points should be spaced at 300 - 400 mm centres.

- a) Insert the appropriate wheel axle (N) (standard, extended or smooth track) into the top hanger (U) Fig 2.2.6.
- b) Attach the top hangers to the top corners of the panel, using the vertical slots only Fig 2.2.7.

NOTE: The additional two fixings will be fitted to the left and right side after the panel is lowered into the tracks and adjusted to vertical Fig 2.2.8.

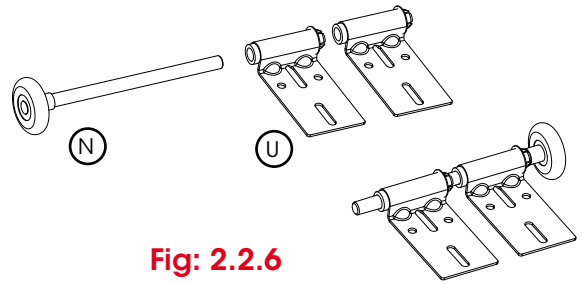

Fig: 2.2.6

! WARNING! Ensure all tek screws indicated are fitted after adjusting.

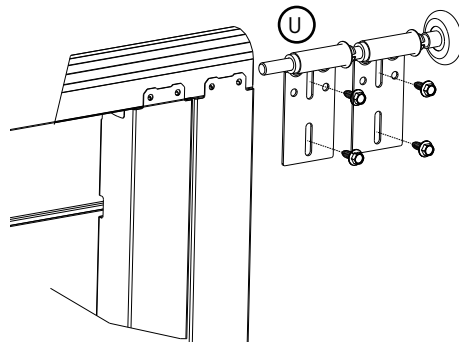

Fig: 2.2.7

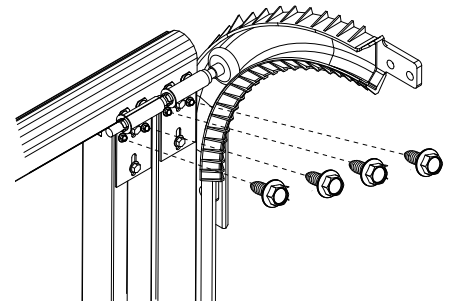

Fig: 2.2.8

2.3 fitting reinforcing & end hooks to bottom & middle panel

Reinforcing and hook plates are fitted to the centre of the bottom and middle panels. Take special note of the detail shown and the position and quantity of the fixings. B&D Storm-Shield™ PFI reinforcing must be cut 80mm less than the panel width.

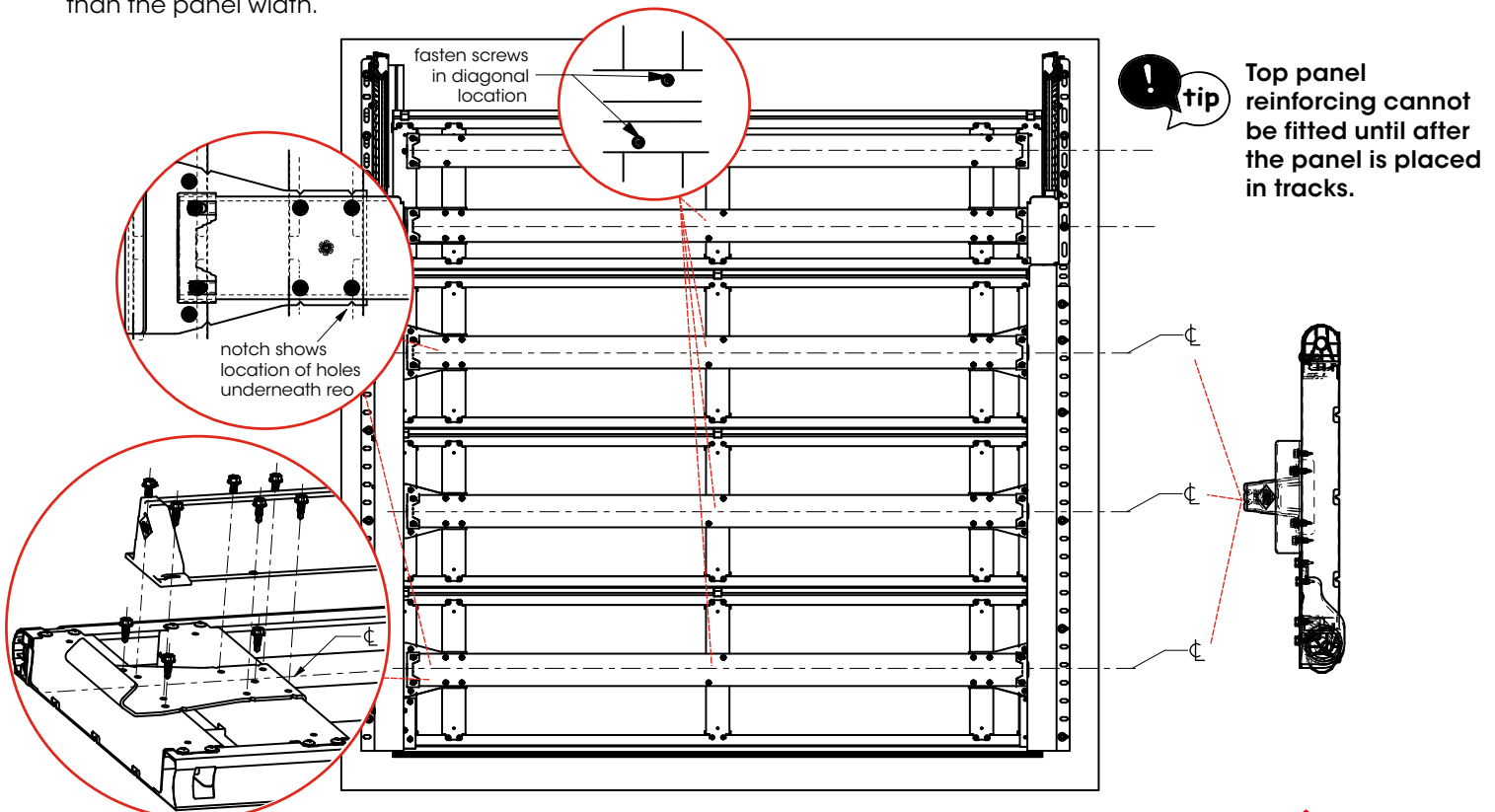

Fig: 2.3.1



3.0 installation

3.1 installing vertical tracks

CAUTION: If jamb seals are being fitted they should be cut 100mm taller than the door height and fitted prior to fitting the vertical tracks.

- a) Set the vertical tracks parallel on both sides of the door. Use the level/datum marks to ensure the tracks are level with each other or the door will not function correctly. Fig 3.1.1
- b) Ensure to follow the measurements as shown in Fig 3.1.2 to set out the placement of the track and brackets. The fixing points should be spaced at 300-400mm centres.
- c) Take note of the positioning of the jamb spacer (F) as it must be fitted under the jamb bracket (I) with the rolled edge facing the door as shown in Fig 3.1.2
- d) Once satisfied temporarily fix in position with at least **three (3) fixings** to the top bracket and one to each of the lower track brackets. These will hold the tracks in position and allow for minor adjustments.

WARNING! All fixings with washers must be fitted after the door is fully adjusted and operating satisfactorily. Refer to the DTCM compliance instructions & Wind Region Drawings.

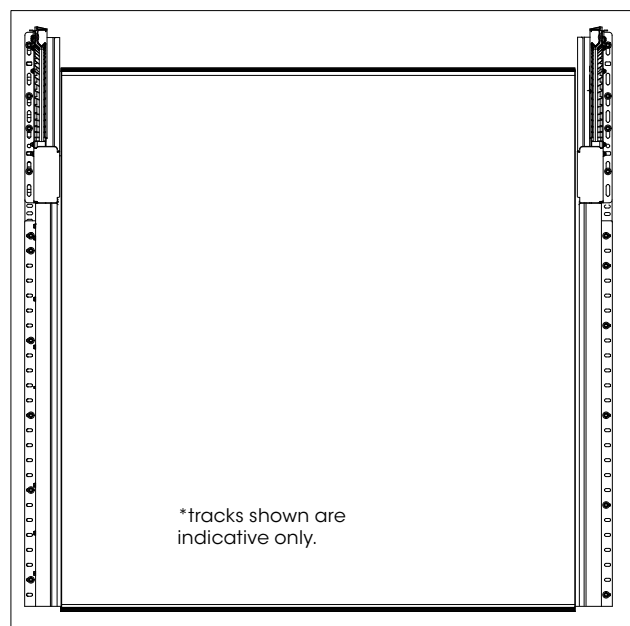

Fig: 3.1.1

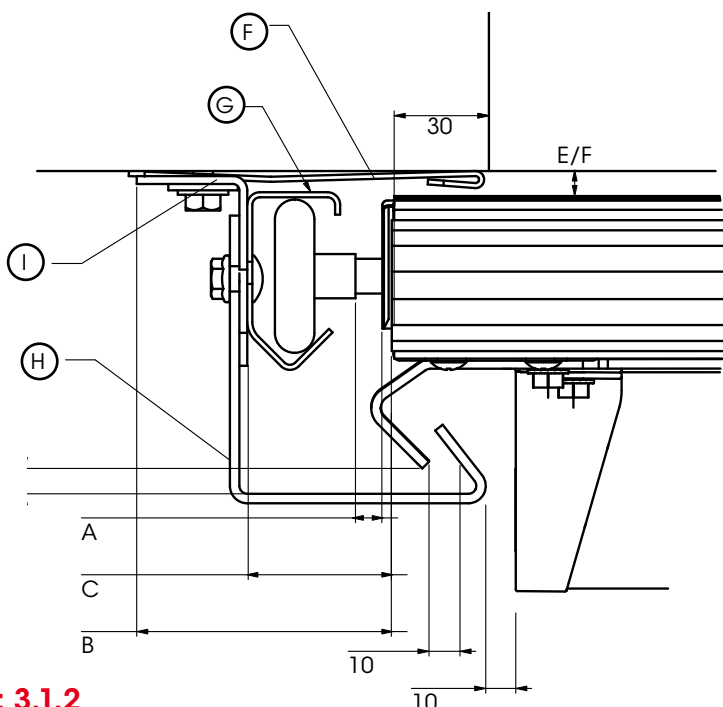

Fig: 3.1.2

detail	A at bottom axle	B	C	D	E/F
B&D Storm-Shield™ PFI (single wheel)	5mm	90mm	50mm	n/a	17/12mm

NOTE: These measurements allow for final adjustment.



3.2 adding panels



TWO PERSON LIFT: depending on the size of the door, this process may require two persons to lift into place.

- a) Carefully lower the wheels of the bottom panel into the tracks and lower so the panel is sitting level in the door opening.
- b) Check that the wheels are sitting in the "V" groove of the vertical track on each side and there is sufficient clearance between the panel and the track as per Fig 3.1.2.
- c) Insert the next panel into the tracks and rest on top of the bottom panel. Fig 3.2.2.

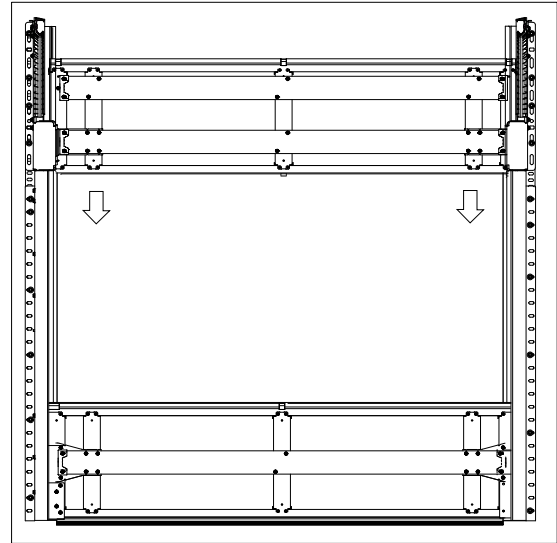

Fig: 3.2.1

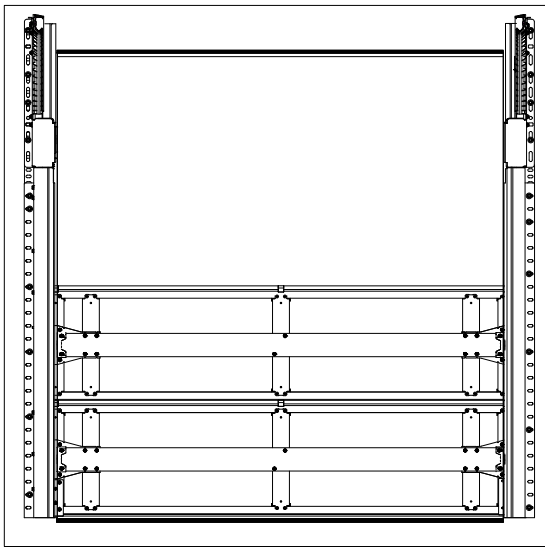

Fig: 3.2.2

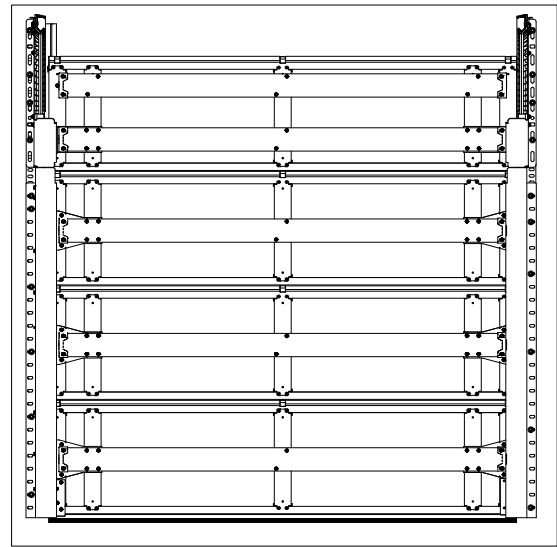

Fig: 3.2.3



WARNING! Use caution when adjusting and securing hinge links between panels as pinching may occur.

- d) Starting in the centre, lift the panel enough to ensure each link is in its respective recess and held into place by a hinge pin.
- e) Repeat this procedure for all other panels with the exception of the top panel which has externally mounted adjustable metal hangers.
- f) Once the top panel is in place and adjusted to vertical the additional locking fixings in the top hanger must be added. Fig 3.2.4.



CAUTION: Ensure the warning label is placed on the door in a clearly visible position.

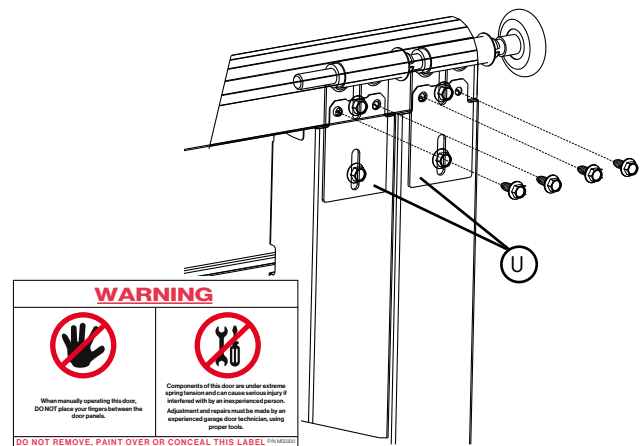

Fig: 3.2.4

3.3 installing horizontal tracks

Assemble the track as shown in Figure 3.3.1, ensuring that a washer is used under the wiz nut.

The plastic curve must align and butt up against the vertical track and horizontal track snugly.

Before bracing the horizontal tracks, ensure that they are square to the opening and level. To check whether your diagonals are equal:

- Measure from the top of the vertical track to the end of the horizontal track.
- Check both sides.
- Adjust if necessary.

The track support must be located along the horizontal track approximately at $\frac{3}{4}$ door height. For doors higher than 2280mm and/or wider than 5000mm two supports will be required.

! WARNING! Failure to position supports approximately $\frac{3}{4}$ door height along the track can result in the tracks twisting out.

- Calculate the horizontal track brace position as per section 1.4.2.
- Measure along the horizontal track to the desired position and find a structurally sound location to fix your support to the ceiling or side wall. Fig 3.3.2.
- Each installation must be assessed individually for ceiling fixing requirements.

! WARNING! For all insulated panels two (2) ceiling supports must be fitted per horizontal track for all doors over 2400mm x 3000mm.

The safety stop must always be fitted to prevent the panels from accidentally exiting the track

- Install the safety stop at the end of the horizontal track as shown in Fig 3.3.3.

! WARNING! The safety stop must be installed. Failure to do so may cause serious personal injury or damage to property.

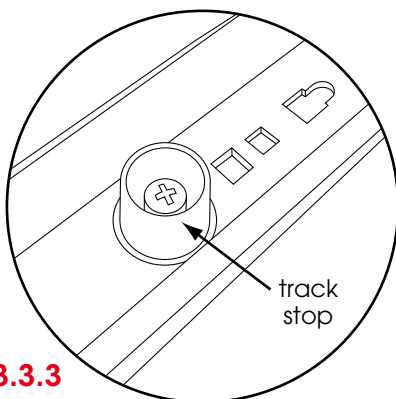

Fig: 3.3.3

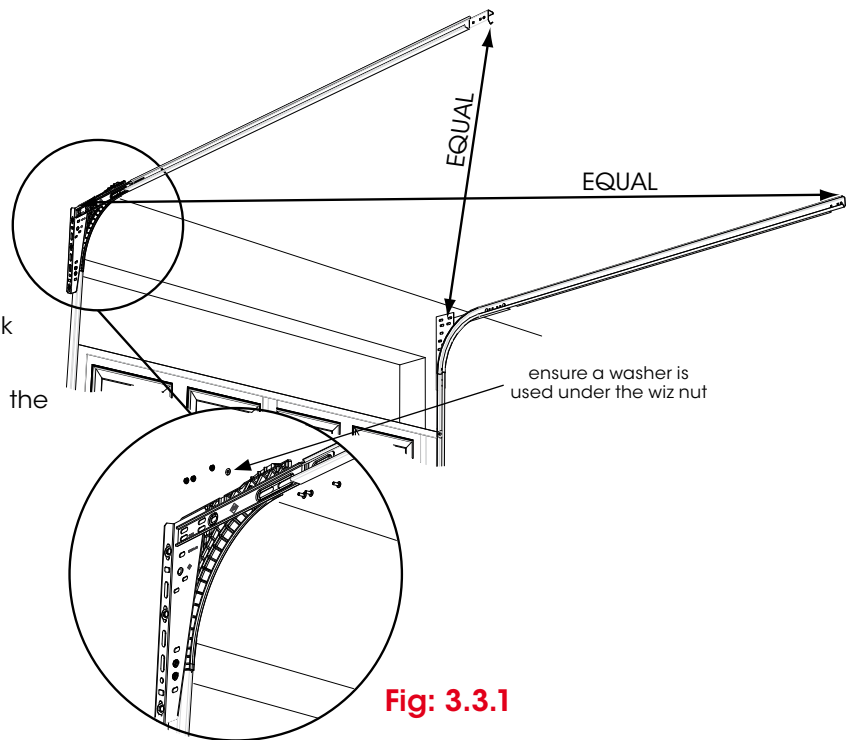

Fig: 3.3.1



Check that the clearance in the vertical tracks as per Fig 3.1.2 is also in the horizontal tracks

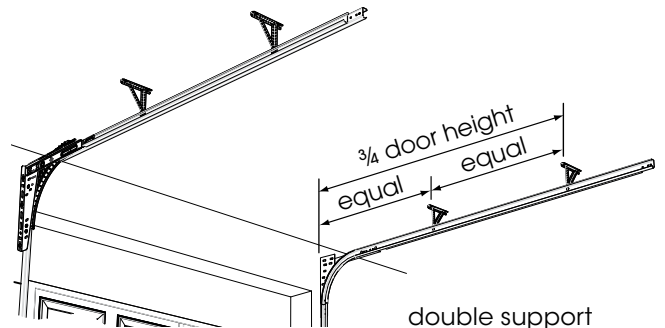
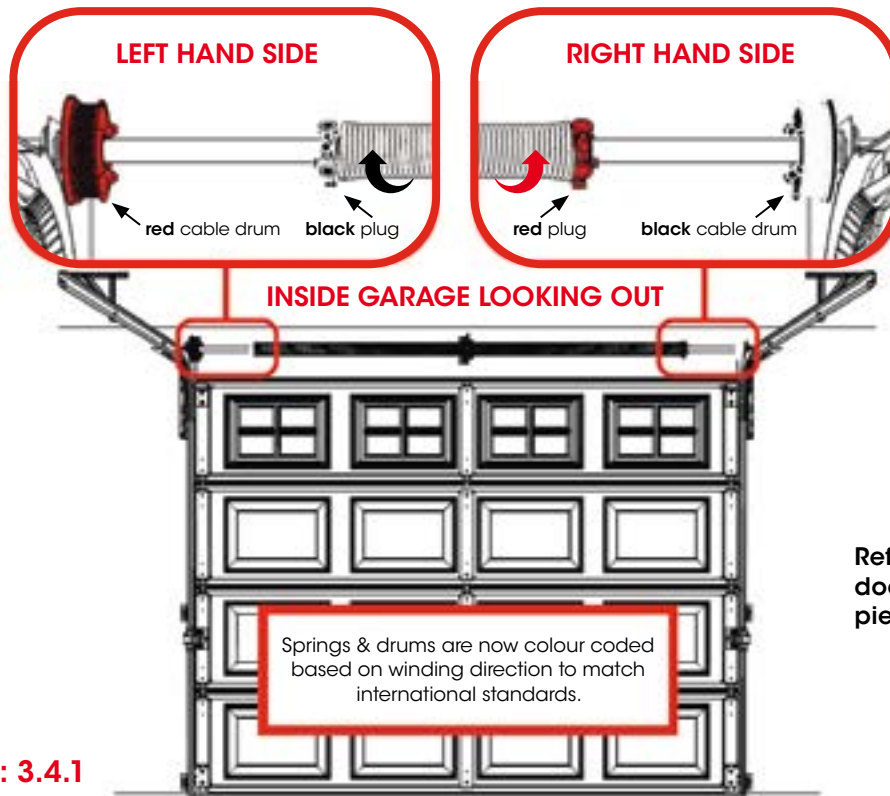

Fig: 3.3.2



Refer to appendix for large doors containing two piece shafts.

Fig: 3.4.1

3.4 standard spring counterbalance system

The springs and drums for the counterbalance system are now colour coded to easily identify which side of the centre bracket the spring is placed. Fig. 3.5.1.

- a) Determine whether the spring anchor bracket (S) is going to be mounted to the wall or ceiling as per Fig 3.4.2 and ensure the cut corner of the bracket is facing down.
- b) Place the torsion bar (B) on the floor and slide the spring anchor bracket (S) onto the torsion bar, positioning it approximately half way along.

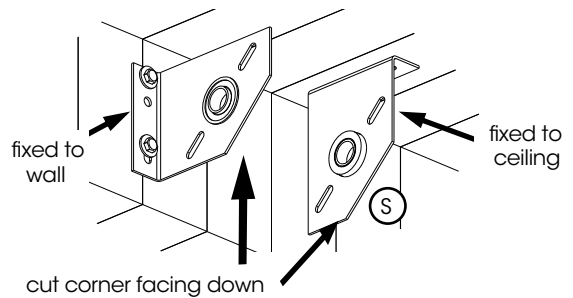

Fig: 3.4.2

tip the bearing flange in the spring anchor bracket must face the spring in single spring mountings.

- c) Locate the cable drum/s (M), spring/s (K), shaft collar (X), washers (J) and side bearing brackets (T) and assemble them as shown in Fig. 3.4.3.

NOTE: 6 panel high doors over 6000mm wide and 7 panel high doors over 5000mm wide require 5-18 cable drums.

- d) Ensure the shaft collar is butted up against the anchor bracket and fixed to axle on spring side of anchor bracket.

NOTE: Shaft Collar not required in double spring mountings.

CAUTION: DO NOT tighten bolts in cable drums yet

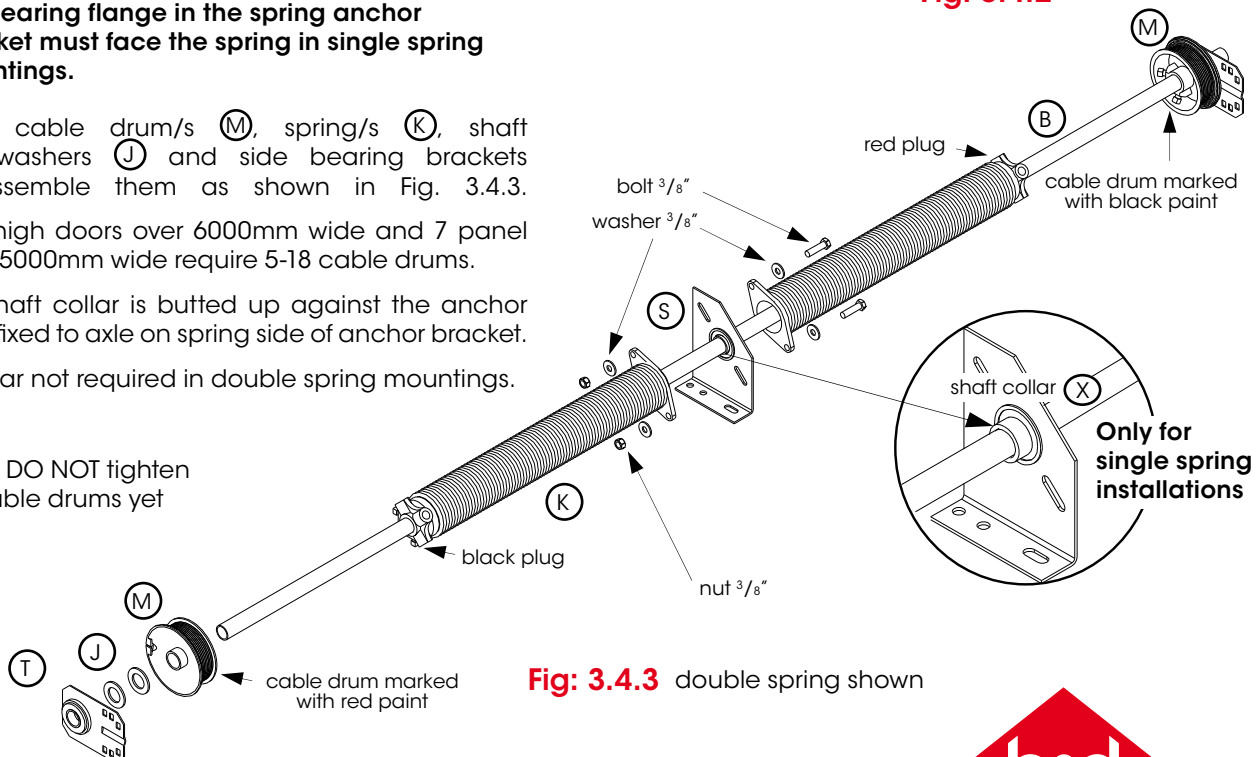

Fig: 3.4.3 double spring shown



3.5 install torsion bar

Before lifting the torsion bar into position, check there is a solid foundation of either brickwork, timber studs, head or ceiling that will support the lifting system correctly.

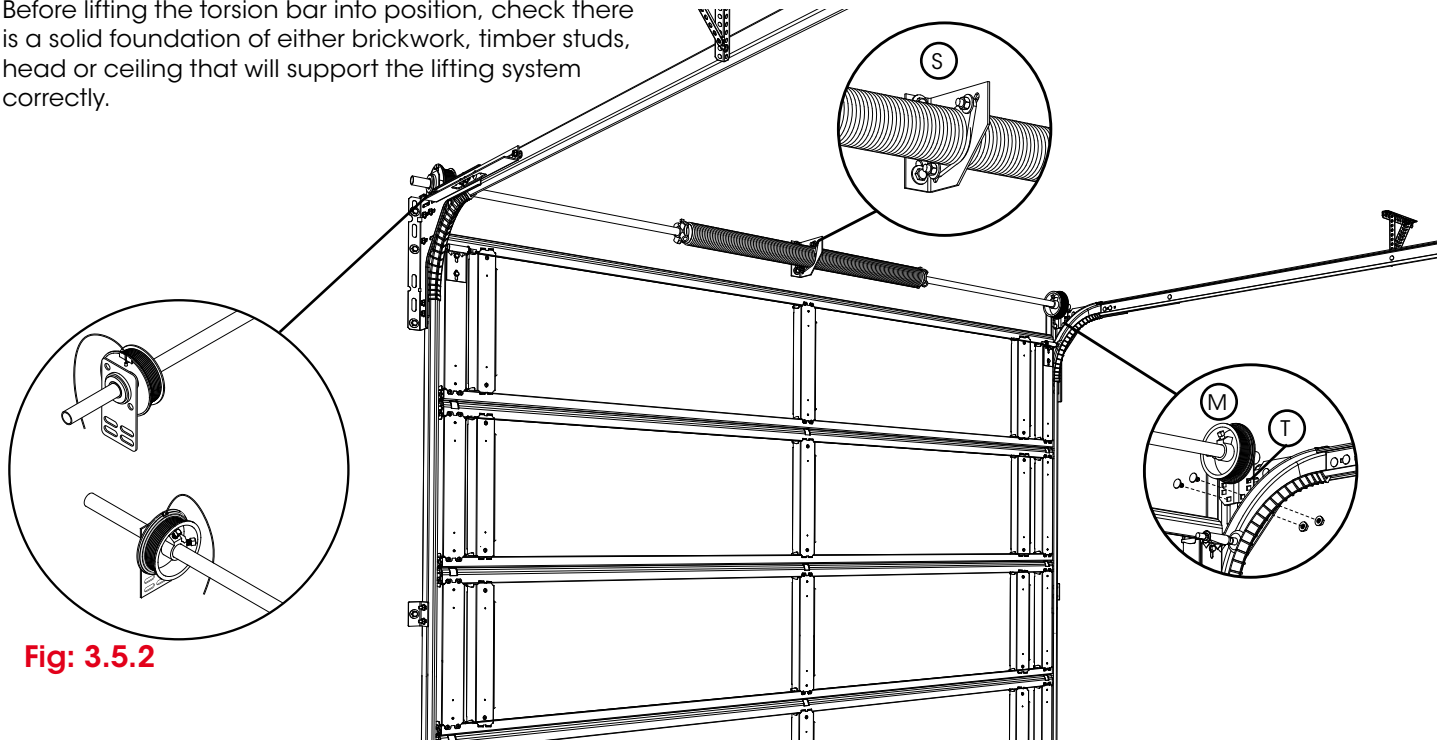

Fig: 3.5.2

Fig: 3.5.1

- Lift the torsion bar assembly into position, resting both ends over the top of the horizontal tracks. Fig. 3.5.1.
- Ensure that the side bearing brackets (T) and cable drums (M) are situated on the inside of the horizontal tracks.
- Line up the spring anchor bracket (S) with the middle of the door, so that the cut corner is facing down.
- Slide the torsion bar assembly towards the wall so the spring anchor bracket can touch the wall (the axle must be parallel with the opening).
- Secure the spring anchor bracket to the wall/ceiling and the side bearing brackets to the tracks as shown in Fig 3.5.1.
- Attach the lifting cable to the cable drum by slipping the cable into the slot on the outside groove. (the ferrule will prevent the cable from coming out) Fig 3.5.2.
- Wind the cable by hand by turning the cable drum away from the door.
- Once the cable is taut, slide the cable drum against the side bearing bracket and tighten the screws to the torsion bar. Fig 3.5.3.

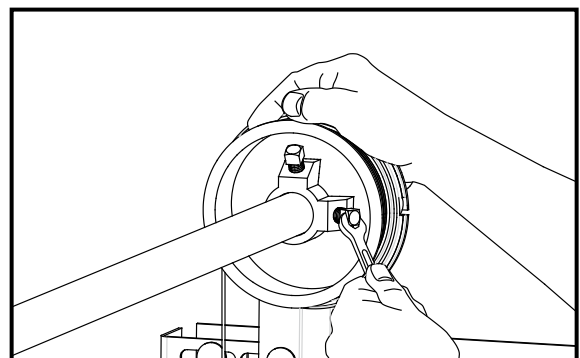

Fig: 3.5.3



CAUTION: Be careful not to over tighten the set-screws

3.6 adding tension to spring

WARNING! Torsion springs can cause serious injury. DO NOT underestimate the tension in the spring.

WARNING! Keep hands clear of the spring and the spring winding plug at all times.

The number of turns required for each spring is shown on a paper tag attached to the springs. Fig 3.6.1

- a) Secure the torsion bar using 2 pipe wrenches as shown in Fig 3.6.2.
- b) Turn the spring by inserting winding bars into the plug holes of the spring and wind up in the direction towards the opening. Fig 3.6.3.

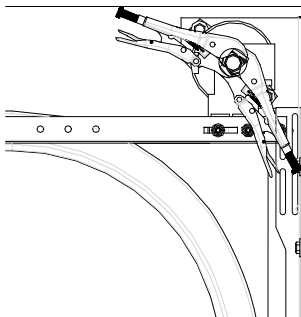

Fig: 3.6.2

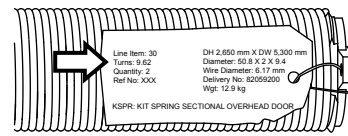

Fig: 3.6.1



The label lists how many full turns. Alternatively, a line is painted along every spring. If the spring is turned 8 times, 8 lines can be seen along the spring

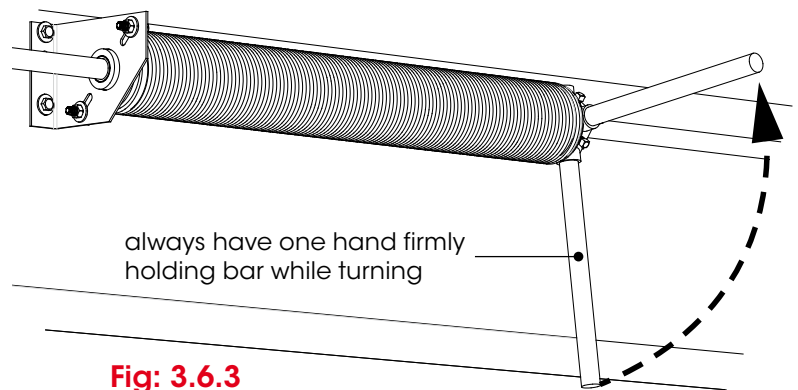
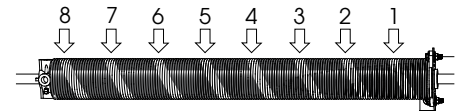

Fig: 3.6.3

WARNING! Always have one winding bar engaged and firmly held while turning and tightening screws.

- c) Once you have completed the turns required, remove one winding bar. If spring snaking occurs, tap the remaining bar back towards the spring anchor bracket.
- d) Maintain firm tension on the winding bar, while using a spanner to tighten the two (2) grub screws. Fig 3.6.4.

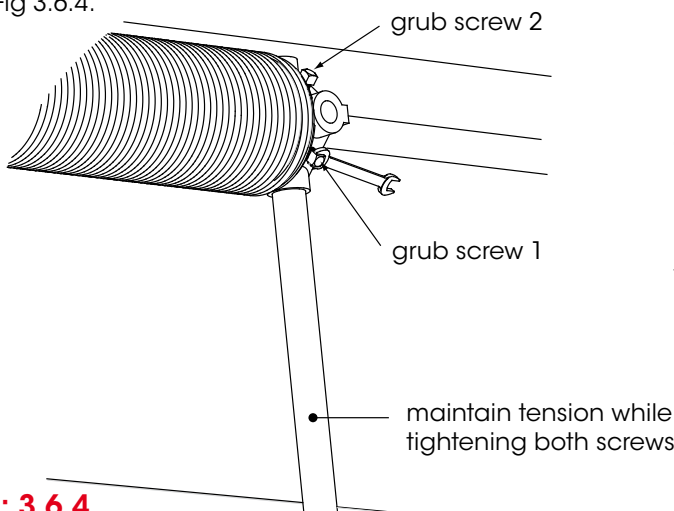

Fig: 3.6.4



CAUTION: Be careful not to over tighten the grub screws.

- e) Repeat this procedure if there is more than one spring, remembering to always wind the spring, whether left or right hand, in an up direction towards the opening.
- f) Check that all screws are properly tightened before removing the wrenches on the torsion bar.



3.7 fitting reinforcing to the top panel

- The two reinforcing bars (C) must be fitted after the panel is in the tracks in a vertical position with the wheels and hangars fitted and adjusted.
- Special care must be taken when fitting the lower reinforcing (C) as the hook plate (Z) must align correctly with the tracklock (H) of the short top track bracket.
- Fit the top reinforcing without hook plates over the top hangar as shown as per Fig 3.7.1b remembering to fasten screws diagonally in the centre as per Fig 3.7.1d .
- The second lower reinforcing with hook plates (Z) is fixed to align with the top section of the Tracklock (H) as per Fig 3.7.1a.

NOTE: Last step - line up reo on top panel with the Tracklock bracket as per Fig 3.7.1c.

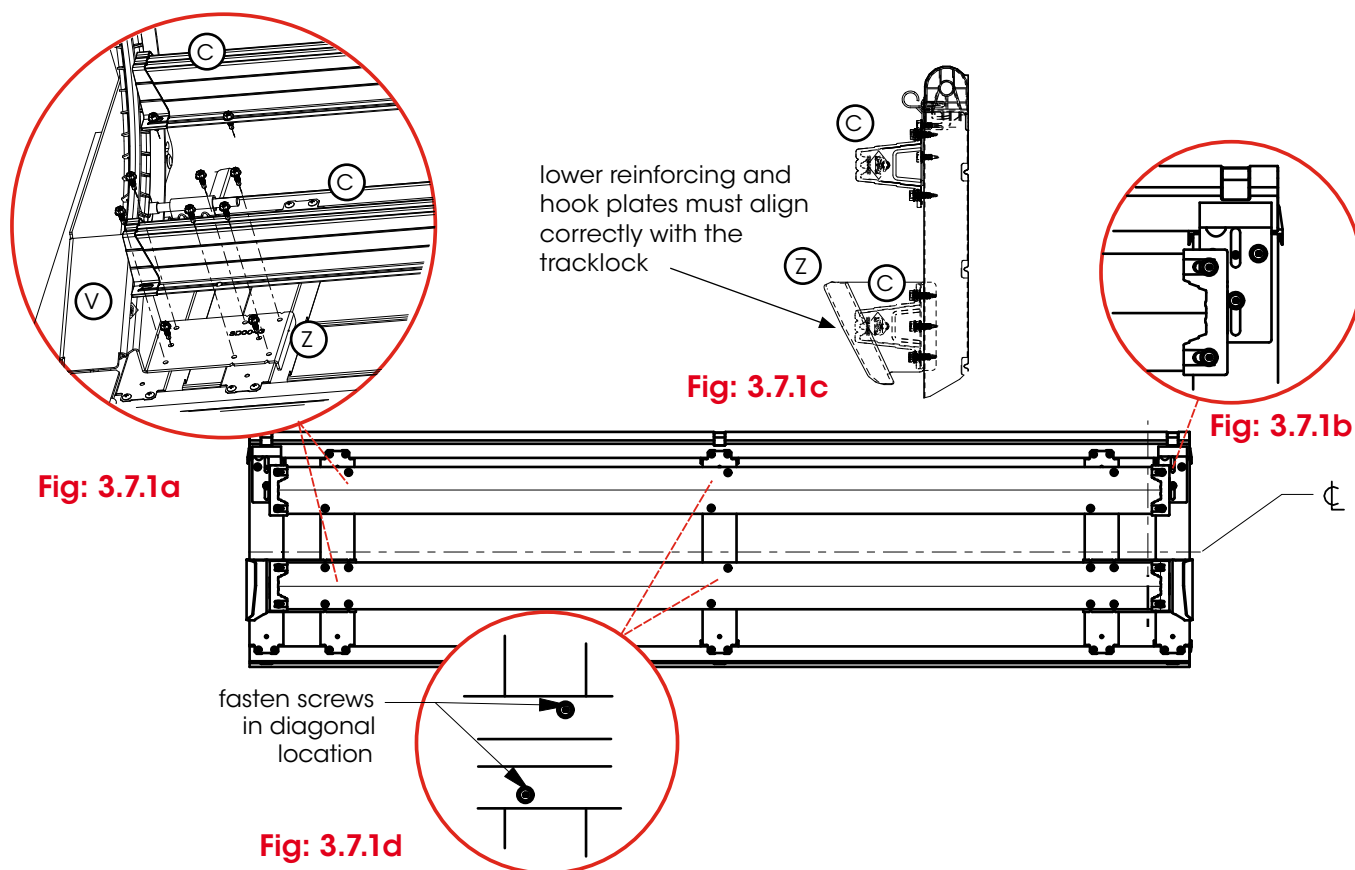

3.8 fitting tracklocks

Whilst fitting tracklocks is shown here it is preferable to leave until the door is fully functioning and you are satisfied with the operation.

for small curve

- The top of the Tracklock (H) must be cut back 60mm as indicated at Figure 3.8.1. Only after removing this material can the tracklock be cut to length from the bottom as a pair.
- After cutting, align the Tracklock (H) with the Jamb Bracket (I). The top of the cut Tracklock should be a snug fit with the bottom of the top track bracket (V). Fig: 3.8.1.

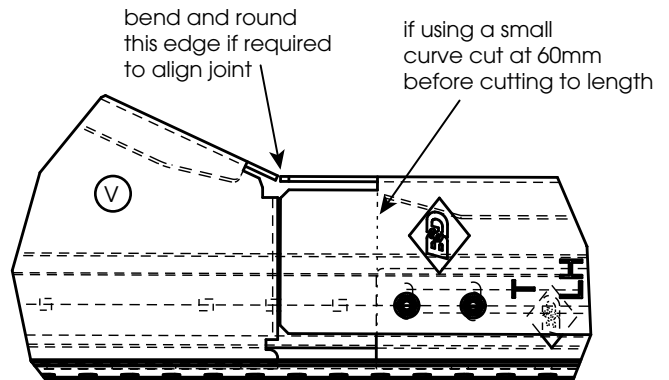

Fig: 3.8.1

for large curve

- if too long only cut as a pair from the bottom. Align the Tracklock (H) holes with the Jamb Bracket (I) as shown in Fig 3.8.3. The top of the uncut Tracklock should be a snug fit with the bottom of the top track bracket (V) as per Fig 3.8.1.
- Attach via the key hole slots (Fig: 3.8.3) and ensure the clearance is correct refer Fig: 3.8.2.
 - When satisfied with clearances and operation a minimum of 5 pairs of 1/4 bolts and washers must be fitted to every metre of track height.
 - When finally satisfied fit all substrate fixings and washers as requested by the DTCM compliance details.

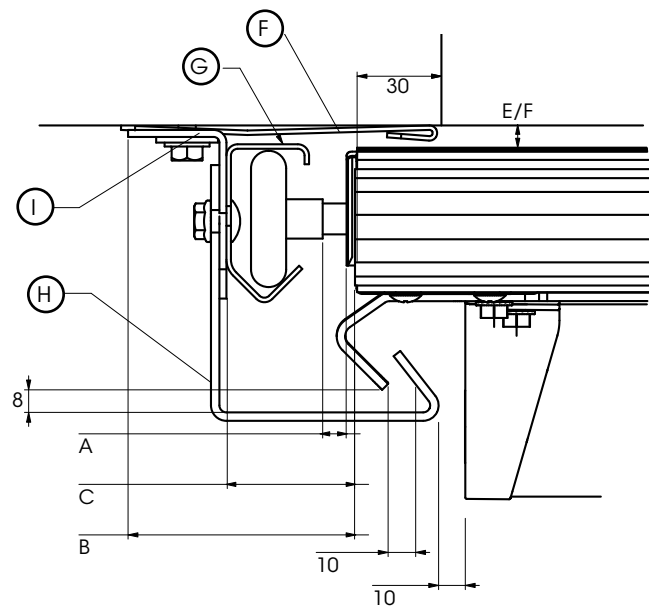

Fig: 3.8.2

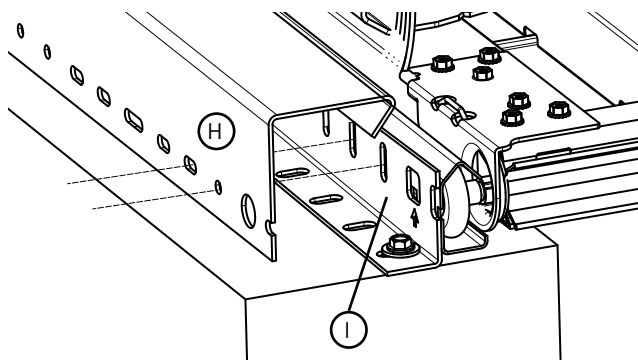

Fig: 3.8.3

3.9 final checks

For optimal performance the door needs to operate efficiently.

- a) Manually move the door up and down, the door should move freely without binding or sticking.
- b) The maximum force required to move the door should not exceed 20kg.
- c) Lift the door to about halfway. When released, the door should stay in place. Fig 3.9.1.
- d) Check that the clearances in the vertical tracks as per Fig 3.1.2 is also in the horizontal tracks.
- e) If you find that the door is binding, open out the horizontal tracks slightly to create the correct tolerance.
- f) Once satisfied that the operation of the door is as near perfect as possible, check that all nuts and bolts are tight.
- g) Oil the springs full length to prevent noise and reduce friction. TAL 5 or similar oil rich lubricant in a pressure spray can is acceptable. Fig 3.9.2

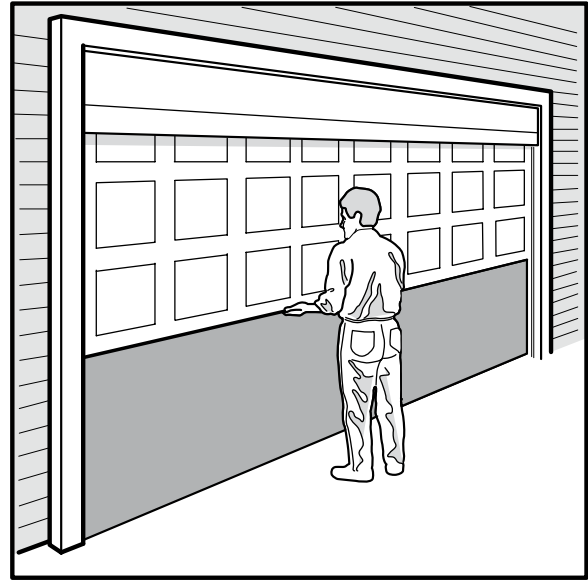

Fig: 3.9.1

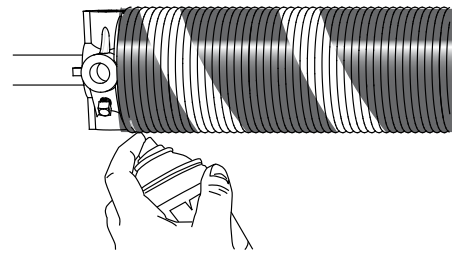

Fig: 3.9.2

4.0 troubleshooting

Symptom	Possible cause	Remedy
lifting cables loose when door is opened	cable drums have slipped diagonals out of square lifting cables not wound till taut	check the screws on the cable drums check the horizontal tracks are square loosen screws on cable drums and wind cables till taut, then tighten screws.
torsion bar moving	cable drums not adjusted correctly springs not adjusted correctly shaft collar not fitted (single spring) end bearing brackets are not straight	check and adjust check spring tension fit shaft collar, see section 3.4. check end bearing brackets are square and vertical
door will not hold up in open position	spring tension not tight enough incorrect placement of springs panel reinforcing fitted incorrectly	check the correct number of turns has been made to spring/s. refer to section 3.6. check the springs are on the correct side/s, refer to section 3.4. check the reinforcing is placed in the correct position, refer to section 2.3 and 3.7.
door not level	water level marks incorrect lifting cable not equally taut	check the water level marks are correct loosen screws on cable drums and wind cables till taut, then tighten screws.
door moving to one side	clearances incorrect cable drums not close to end bearing brackets	check the clearance/overlap of the door is equal on each side. loosen screws on cable drums and ensure they are hard up against the end bearing bracket and tighten screws.
door panels jamming / rubbing on tracks	incorrect clearance between wheel and vertical track door not level cable drum not lined up correctly vertical tracks not parallel lifting cables slipping	Check that the clearances per Fig 3.1.2 are the same in both vertical and horizontal tracks. check water level marks are correct. loosen screws on cable drums and ensure they are hard up against the end bearing bracket and tighten screws. Check that the clearances per Fig 3.1.2 are the same on both vertical tracks. loosen screws on cable drums and wind cables till taut, then tighten screws.
door hard to lift	spring tension spring may have slipped on set screws wrong spring panel reinforcing	check the correct number of turns has been made to spring/s. refer to section 3.6. check spring plug grub screws are tight, refer to section 3.6 check the springs are on the correct side/s, refer to section 3.4. check the reinforcing is placed in the correct position, refer to section 2.3 and 3.7.

common spring problems

symptom	possible cause	rememdy
door raises from the floor and hangs down in opening	cable length too long with cable not on high portion of drum	shorten cable length until the cable rolls onto the flat portion of the drum when the door starts into the horizontal position
	springs may be too strong (too short)	replace spring
	wrong cable drums for springs (too small)	replace cable drums
door lifts from the floor and runs away at the top	door is over tensioned, too many turns on spring or wrong spring	ensure that the correct spring is supplied (if not replace) and that it has the correct number of turns applied
	wrong cable drums for spring, (too small)	replace cable drums
door falls to the floor and hangs down in the opening	door is under tensioned too few turns on spring or wrong springs	ensure that the correct spring is supplied (if not replace) and that it has the correct number of turns have been applied
	wrong cable drums for springs (too large)	replace cable drums
door falls to the floor and runs away at the top	lifting cable may be too short for high lift cable drum or vertical lift drum and is sitting too high on the spiral portion of the drum	increase the cable length to bring the cable down lower on the spiral
	torsion springs too long	shorten springs
door balances at the floor but runs up or down in between	cables in wrong position on spiral of the drums	adjust cable length
poor balance throughout	winding spring in wrong direction	wind in correct direction
	door weight incorrect	supply correct springs
	springs binding	fit torsion bar collar lubricate springs
	door not level	cable lengths are equal equal turns on both springs level door during installation

5.0 appendix

5.1 hinged tapers

Tapers are accomplished using a small customised panel, which results in a slight variation in the installation process.

- Assemble the bottom panel taking note that there are no wheels or weather strip on the bottom panel, these are both on the taper panel. Fig 5.1.1.
- Assemble the tapered panel as shown in insert of Fig 5.1.1. The 2 spacers required are to be cut 10-12mm long from a white link pin and fitted one to each side as shown.
- Connect the tapered panel to the bottom panel using 3 x hinge pins provided.

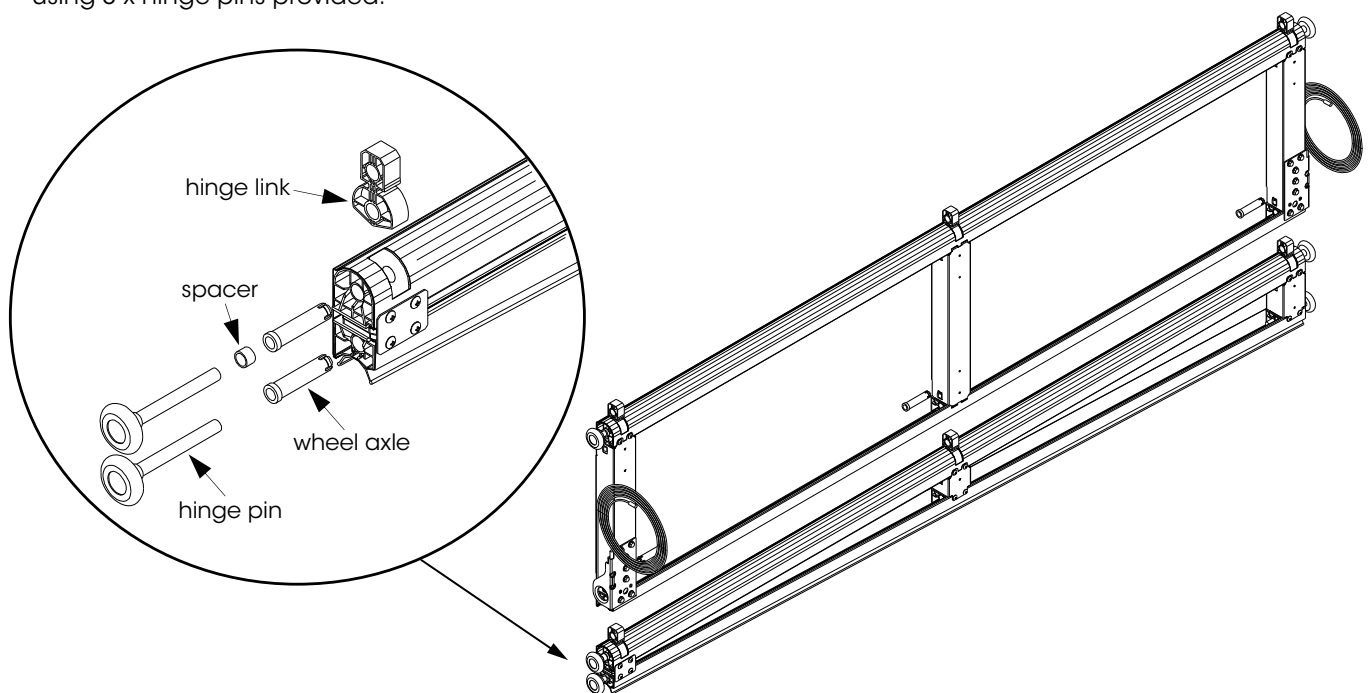

Fig: 5.1.1

Tracks are assembled as standard with the only difference being that one vertical track needs to be cut down to accommodate the uneven floor.

- Start with both of the verticals tracks from the ground and measure up to the level datum.
- Cut the tracks as necessary from the ground end.
- Follow the directions in section 3.1 to install tracks, before proceeding to adding panels in section 3.2.

5.2 two piece shafts for large doors



TWO PERSON LIFT: For large doors, this process may require two persons to lift into place and a ladder or scissor lift to support while fixing into place.

The springs and drums for the counterbalance system are now colour coded to easily identify which side of the centre bracket the spring is placed. Fig. 5.2.1.

- Place the 2 x torsion bars (B) on the floor and slide the 2 x spring anchor bracket (S) onto the torsion bar, positioning them towards the middle.
- Slide on the roller bearing and springs (K), ensuring the roller bearing is butted up against the spring anchor bracket (S) and spring (K).
- Connect each assembly together using 2 x 3/8" washers and bolts.
- Place the cable drums on each end.



CAUTION: DO NOT tighten bolts in cable drums yet

- Mount the remaining 2 x spring anchor brackets to the wall above the horizontal track.

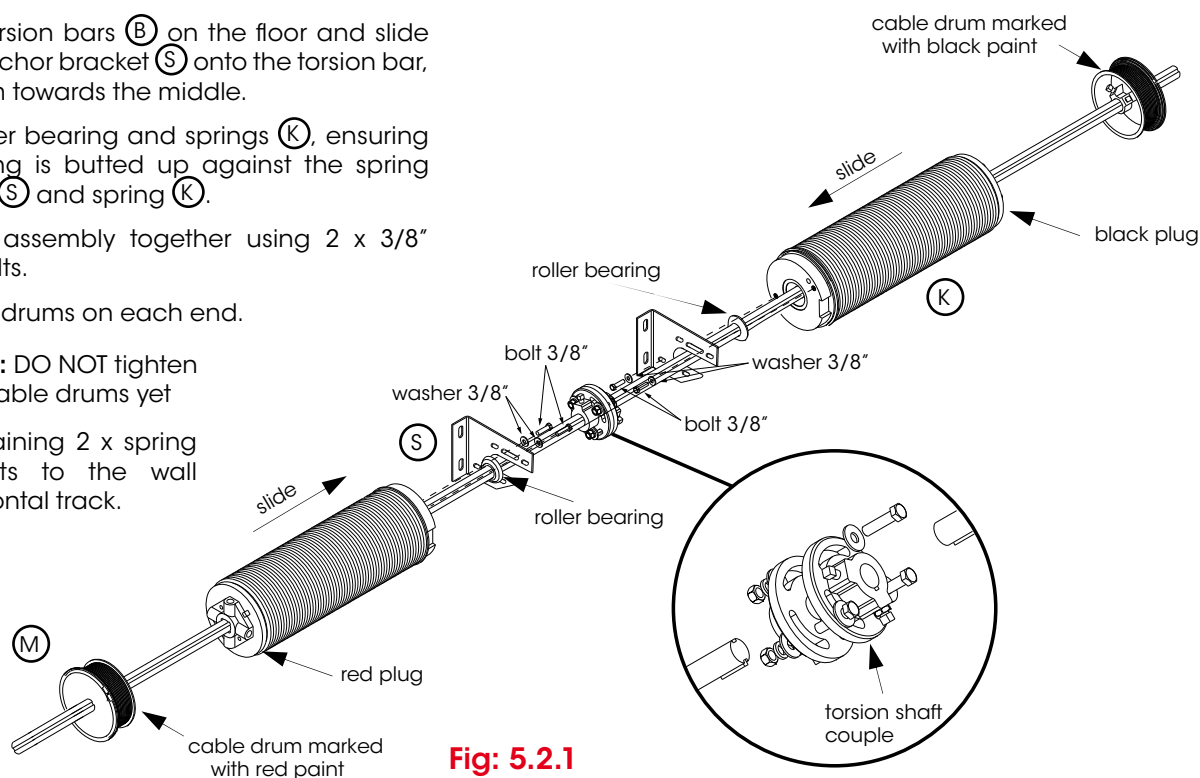

Fig. 5.2.1



TWO PERSON LIFT: Next step may require two persons to lift into place and a ladder or scissor lift to support while fixing into place.

- Lift and thread the right hand side of the assembly through the mounted spring anchor bracket and fix the loose spring anchor bracket securely to the wall.
- Assemble the torsion shaft couple, without tightening the bolts and slide onto the end of the torsion bar, ready to connect to the other torsion bar.
- Repeat step f) for the left hand side assembly.
- Position the torsion shaft couple in the middle as shown in Fig 5.2.1, the axles should be flush with each couple allowing free rotation to occur.
- Cut torsion shaft key in half and insert into torsion bar at the torsion shaft couple, and fix into place by tightening the grub screws on the shaft couple Fig 5.2.2.

insert key then fix into place with grub screw

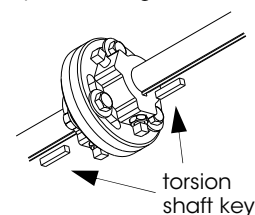

Fig. 5.2.2



CAUTION: Be careful not to over tighten the set-screws

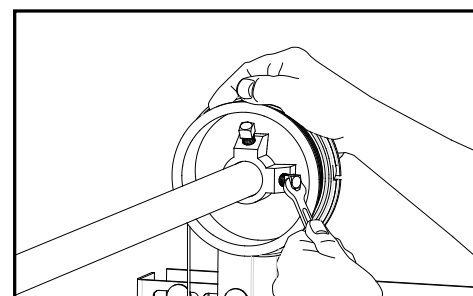

Fig. 5.2.3

tip Unwind the lifting cable from the bottom panel.

- Attach the lifting cable to the cable drum by slipping the cable into the slot on the outside groove. (the ferrule will prevent the cable from coming out) .
- Wind the cable by hand by turning the cable drum away from the door.
- Once the cable is taut, slide the cable drum against the side bearing bracket and tighten the screws to the torsion bar. Fig 5.2.3.
- Proceed to section 3.7 to tension the springs.

5.3 after installation care

cleaning

COLORBOND® & COLOURED STEEL FINISH

Your B&D Paneliff® has been pre-painted with a high durability polyester paint system, especially designed and tested for the harsh Australian conditions. However, all exposed surfaces require some attention to guard against the premature onset of corrosion and any other harmful atmospheric effects. In our atmosphere there are harmful deposits that gather on the door surface and if not removed regularly, will seriously affect the appearance and life of the door.

Washing of the door with clean water and a cloth every 14 days is recommended – particular care should be taken to clean areas of the door not normally washed by rain.

hinges & hangers

PLASTIC HINGES: No lubrication is generally required, however silicon spray or lithium grease may be used if necessary.

cables

Check the cables regularly for corrosion, fraying or tangling, if any of these are evident call your service provider.

regular maintenance required

B&D recommends that you check the operation of your Paneliff® at least every six months (more regularly in extreme environments or frequent use). The effort required to manually open and to manually close the door should be about the same (if door has an automatic opener, put into manual mode before testing door).

If the door is difficult to operate in either direction (up or down) then check that the inside surfaces of the guides are clean and free of obstructions.

If the door is still difficult to operate, then your door will need a service to adjust the spring tension and possibly other operational parts of the door.

This service should only be carried out by an experienced door technician, using the correct tools.

If you have an automatic opener fitted to your door, it is particularly important that you ensure the optimum operation of the door, otherwise you may reduce the effective life of the opener.

To keep your door running well, it is recommended that your door be serviced, by an experienced door technician, every 12 months (more regularly in extreme environments or frequent use), or earlier if required.

spring tension

It is natural for springs to lose tension over time. When spring tension is adjusted or when your door is first installed it is usual to apply a little more tension than is required for balanced operation, to allow for the normal "settling in" of the springs. Lightly lubricate to prevent friction between the coils.

warranty

Warranty conditional on proper care as recommended above. Full details of the warranty are available in your owners handbook, from your nearest B&D office or visit the B&D website www.bnd.com.au

b&d doors office locations

Head Office	6-8 Fiveways Blvd, Keysborough 3073	Phone (03) 9791 2000
New South Wales	34 Marigold St, Revesby 2212	Phone (02) 9722 5555
Queensland	17 Oasis Court, Clontarf 4019	Phone (07) 3883 0200
Victoria	147-153 Canterbury Rd, Kilsyth 3137	Phone (03) 9237 7766
South Australia	23 Frederick Rd, Royal Park 5014	Phone (08) 8440 4747
Western Australia	96 Mulgool Rd, Malaga 6090	Phone (08) 9247 8777
International/Export	34 Marigold St, Revesby 2212	Phone +61 (0)2 9722 5555

your representative is