

B&D STORM SHIELD HIGH WIND SECTIONAL DOOR - ELEVATION
MAXIMUM DOOR WIDTH = 5.5m

NOTE: DOOR WIDTH (SPAN) (L) = OPENING WIDTH + CURTAIN OVERLAPS
 DOOR HEIGHT = OPENING HEIGHT + TOP PANEL OVERLAP
 1:30

DESIGN CRITERIA:

(REFER ALSO TO NOTES COVERING BASIS OF DRAWINGS & LIMITATIONS)
 DOOR HEIGHT = 3.415m MAX.
 DOOR WIDTH = 5.5m MAX.
 WIND RATING C2 AS GIVEN IN TABLE 5.2 OF AS/NZS 4505:2012 OR APPROXIMATELY EQUAL TO THE FOLLOWING WIND RATING WHEN IN ACCORDANCE WITH AS/NZS 1170.2:2021.

- REGION C
- TERRAIN CATEGORY 2 (INTERNAL PRESSURE COEFFICIENTS $C_{pi} = -0.4, +0.55$)
- TERRAIN CATEGORY 2.5 (INTERNAL PRESSURE COEFFICIENTS $C_{pi} = -0.5, +0.65$)
- REGIONAL WIND SPEED $V_R = 66m/s$

THE MAXIMUM DESIGN WIND PRESSURES ARE NOT TO EXCEED THE FOLLOWING MAGNITUDES:

1. FOR DOOR WIDTHS LESS THAN 4m
 - ULTIMATE DESIGN INWARD WIND PRESSURE = 2.92KPa.
 - ULTIMATE DESIGN OUTWARD WIND PRESSURE = -3.37KPa.

2. FOR DOOR WIDTHS GREATER THAN 4m
 - ULTIMATE DESIGN INWARD WIND PRESSURE = 2.92KPa.
 - ULTIMATE DESIGN OUTWARD WIND PRESSURE = -3.04KPa.

LIMITATIONS:

- STEEL ABUTMENT SUPPORT POSTS TO BE 3.0mm (MIN.) AND A MINIMUM STRESS GRADE OF 250 MPa U.N.O.
- CHARACTERISTIC UNCONFINED COMPRESSIVE STRENGTH OF BLOCK WALL UNIT (f_{uc}) = 15 MPa (MIN.)
- CORE FILLING OF BLOCKWALL (f_c) = 15 MPa (MIN.)
- ALL DOOR COMPONENTS TO BE IN ACCORDANCE WITH STANDARD B&D STORM SHIELD HIGH WIND SECTIONAL DOOR MANUFACTURING.
- DOOR INSTALLATION TO BE IN ACCORDANCE WITH STANDARD B&D STORM SHIELD HIGH WIND SECTIONAL DOOR INSTALLATION GUIDELINES.
- THE STRUCTURE TO WHICH THE DOOR IS ATTACHED SHALL BE ASSESSED AND CERTIFIED INDEPENDENTLY AS REQUIRED BY A SUITABLY QUALIFIED STRUCTURAL ENGINEER.

LIMITATIONS (continued):

- THE MAXIMUM ULTIMATE DESIGN ABUTMENT CATENARY FORCE $F_x = 18.5KN$ PER METRE HEIGHT OF DOOR FOR ALL SPANS UP TO 5.5m.
- ALTERNATIVE DESIGN PARAMETERS TO WHAT ARE SPECIFIED ON THESE DRAWINGS ALONG WITH ALTERNATIVE SITE SPECIFIC LOCAL PRESSURE FACTORS MAY BE ADOPTED PROVIDED THE CALCULATED SITE SPECIFIC ULTIMATE DESIGN WIND PRESSURES DO NOT EXCEED THE ULTIMATE DESIGN WIND PRESSURE RATINGS SPECIFIED IN THE DESIGN CRITERIA.
- THE BUILDING DESIGN ENGINEER IS TO ENSURE THAT THE SITE SPECIFIC DESIGN WIND LOADINGS DO NOT EXCEED THE ULTIMATE DESIGN WIND PRESSURE RATINGS AS SPECIFIED IN THE DESIGN CRITERIA.
- DOORS MAY BE POSITIONED AT ANY LOCATION ALONG THE BUILDING ENVELOPE INCLUDING ALL LOCAL PRESSURE ZONES (ie. CORNERS OF BUILDINGS), PROVIDED THE CALCULATED SITE SPECIFIC ULTIMATE DESIGN WIND PRESSURES DO NOT EXCEED THE ULTIMATE DESIGN WIND PRESSURE RATINGS SPECIFIED IN THE DESIGN CRITERIA.

NOTES COVERING BASIS OF DRAWINGS

- REPORT No's TS1026 Revision A (CYCLONE TESTING STATION, SCHOOL OF ENGINEERING AND PHYSICAL SCIENCES, JAMES COOK UNIVERSITY).
- PRINCIPLES OF MECHANICS.
- AS/NZS 1170.2:2021-STRUCTURAL DESIGN ACTIONS, PART 2: WIND ACTIONS.
- AS/NZS 1170.1:2002-STRUCTURAL DESIGN ACTIONS, PART 1: PERMANENT, IMPOSED AND OTHER ACTIONS.
- AS/NZS 1170.0:2002-STRUCTURAL DESIGN ACTIONS, PART 0: GENERAL PRINCIPLES.
- AS 4100:2020-STEEL STRUCTURES.
- AS 1720.1:2010-TIMBER STRUCTURES, PART 1: DESIGN METHODS.
- AS/NZS 4600:2018-COLD FORMED STEEL STRUCTURES.
- AS 3700:2018-MASONRY STRUCTURES
- AS/NZS 4505:2012 GARAGE DOORS AND OTHER LARGE ACCESS DOORS.
- AS 3600:2018 CONCRETE STRUCTURES.
- AS 4055: 2021 WIND LOADS FOR HOUSING.
- BUILDDEX FASTENERS-TECHICAL SPECIFICATION.
- RAMSET-SPECIFIERS RESOURCE BOOK.
- REFER TO DESIGN CRITERIA & LIMITATIONS.

ISSUE	DATE	AMENDMENTS
B	13.11.15	ISSUED FOR CONSTRUCTION
C	30.03.16	ISSUED FOR CONSTRUCTION
D	04.03.17	ISSUED FOR CONSTRUCTION
E	14.10.21	ISSUED FOR CONSTRUCTION
F	04.04.23	ISSUED FOR CONSTRUCTION

CLIENT	B&D AUSTRALIA PTY LTD
PROJECT	B&D STORM SHIELD HIGH WIND SECTIONAL DOOR

DRAWING	ELEVATION AND NOTES	SCALE	
		DESIGNED	J.E.
		DRAWN	AAB
		CHECKED & APPROVED	
		DATE	April 2023

DRAWING No.	S01 F
PROJECT No.	2422



www.jamesellisengineers.com.au
 PO Box 251, Padstow NSW 2211
 Ph: 8764 1035

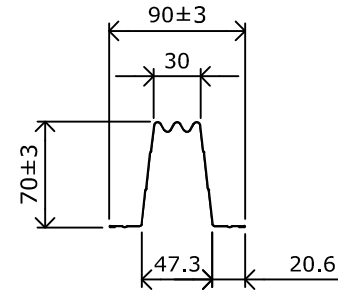

DETAIL A
1:5
TYPICAL STRUCTURAL STEEL REINFORCING BATTEN - (CROSS SECTION PROFILE)
PART NUMBER 0T3158
MATERIAL: 0.55mm G550 GALVABOND

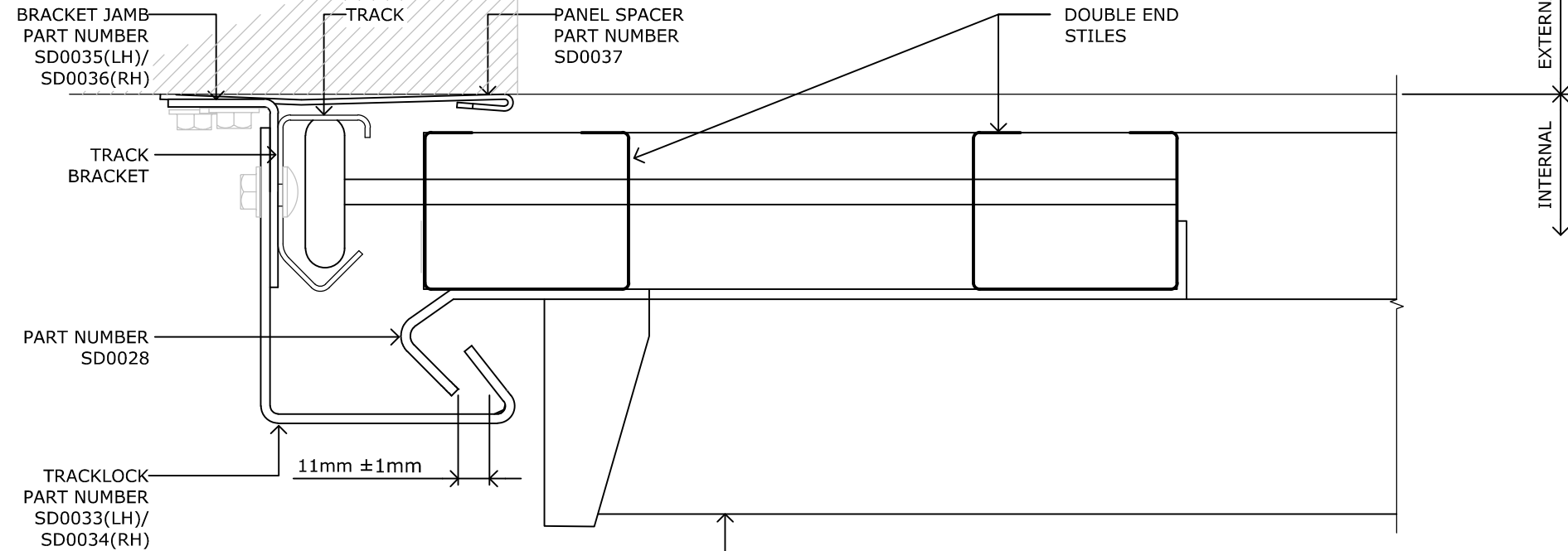

DETAIL B
1:2
TRACKLOCK SUPPORT BRACKET - PART PLAN (CROSS SECTION)

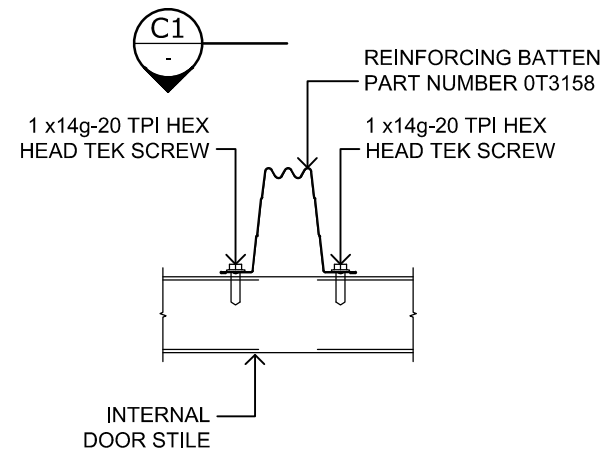

DETAIL C
1:2
TYPICAL AT ALL INTERSECTIONS OF REINFORCING BATTENS AND INTERNAL DOOR STILES

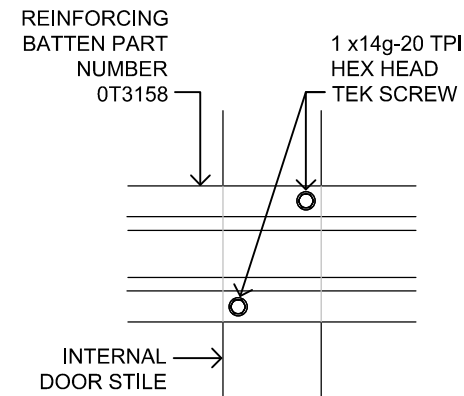

SECTION C1
1:2

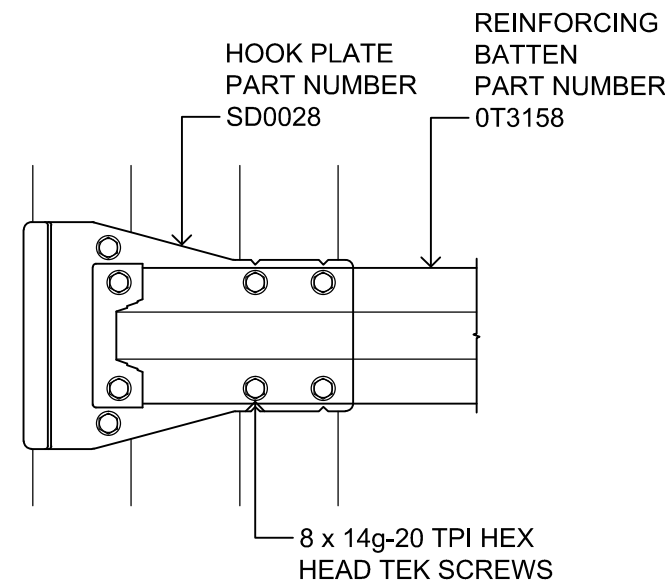

DETAIL D
1:5
TYPICAL AT EACH ENDS OF REINFORCING BATTENS

TABLE 1

FASTENING SPECIFICATIONS ONTO COLD FORMED STEEL ABUTMENT SUPPORTS COMPLYING WITH AS 1397-2011

MATERIAL THICKNESS (t)mm	GRADE	YIELD STRENGTH	TENSILE STRENGTH	SPACING (mm)
1mm	G550	550 MPa	550 MPa	125mm
1.2mm	G500	500 MPa	520 MPa	150mm
1.5mm	G450	450 MPa	480 MPa	200mm
1.9mm	G450	450 MPa	480 MPa	250mm

ISSUE	DATE	AMENDMENTS
B	13.11.15	ISSUED FOR CONSTRUCTION
C	30.03.16	ISSUED FOR CONSTRUCTION
D	04.03.17	ISSUED FOR CONSTRUCTION
E	14.10.21	ISSUED FOR CONSTRUCTION
F	04.04.23	ISSUED FOR CONSTRUCTION

CLIENT	B&D AUSTRALIA PTY LTD
PROJECT	B&D STORM SHIELD HIGH WIND SECTIONAL DOOR

DRAWING	DETAILS	SCALE	
JAMES ELLIS & ASSOCIATES Consulting Structural Engineers	DESIGNED	J.E.	
	DRAWN	AAB	
	CHECKED & APPROVED		
	DATE	April 2023	

DRAWING No.	S02 F
PROJECT No.	2422

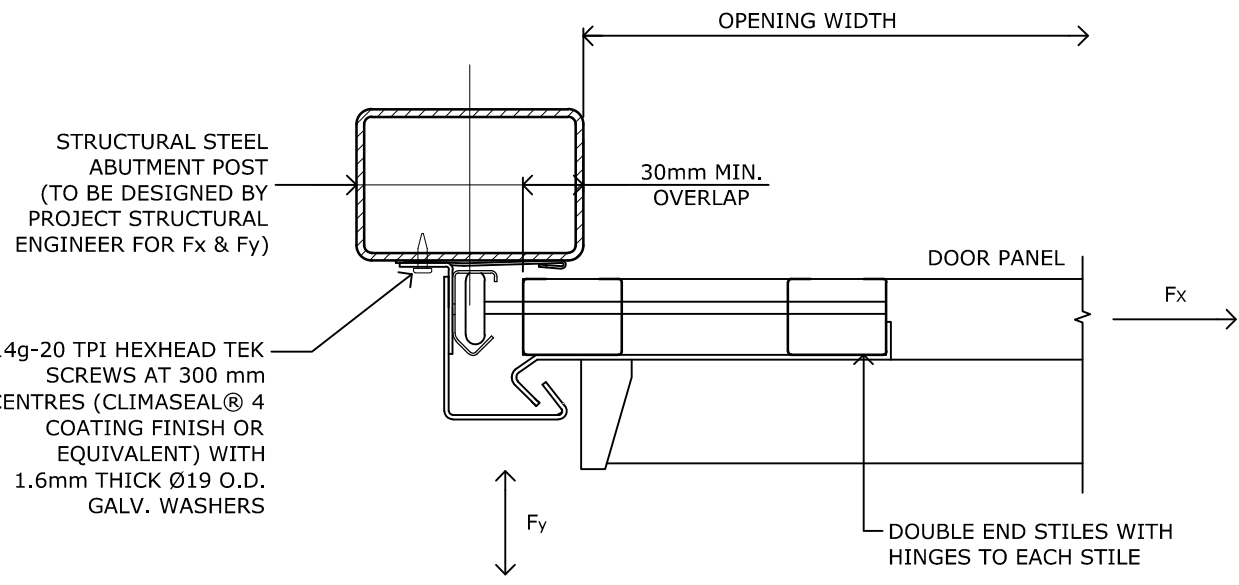

SECTION 1
1:5
PLAN OF TRACK
FIXING TO STEEL
ABUTMENT SUPPORT POST.

NOTE: $F_y = \frac{Wl}{2}$
WHERE F_y = MAXIMUM OUT OF PLANE ULTIMATE DESIGN ABUTMENT FORCE PER METRE
 W = ULTIMATE DESIGN WIND PRESSURE (kPa)
 L = DOOR WIDTH (SPAN) (m)

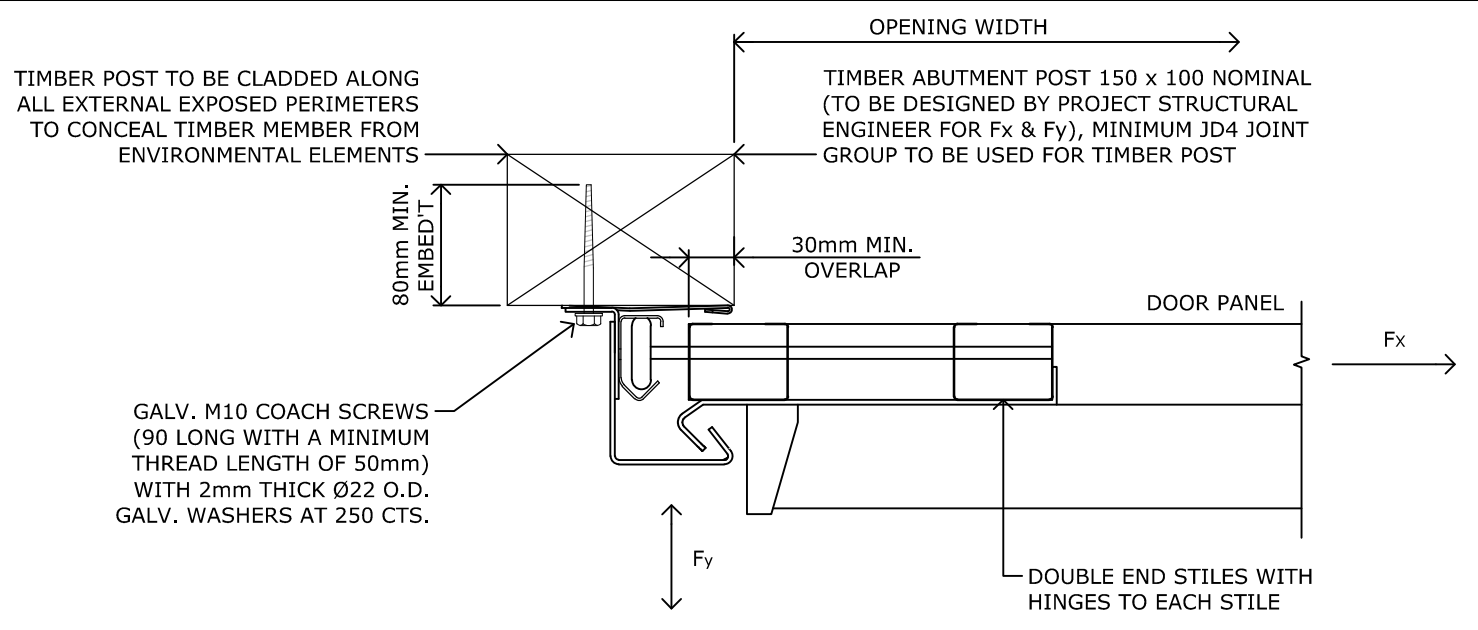

SECTION 1
1:5
PLAN OF TRACK
FIXING TO TIMBER
ABUTMENT SUPPORT POST.

NOTE: $F_y = \frac{Wl}{2}$
WHERE F_y = MAXIMUM OUT OF PLANE ULTIMATE DESIGN ABUTMENT FORCE PER METRE
 W = ULTIMATE DESIGN WIND PRESSURE (kPa)
 L = DOOR WIDTH (SPAN) (m)

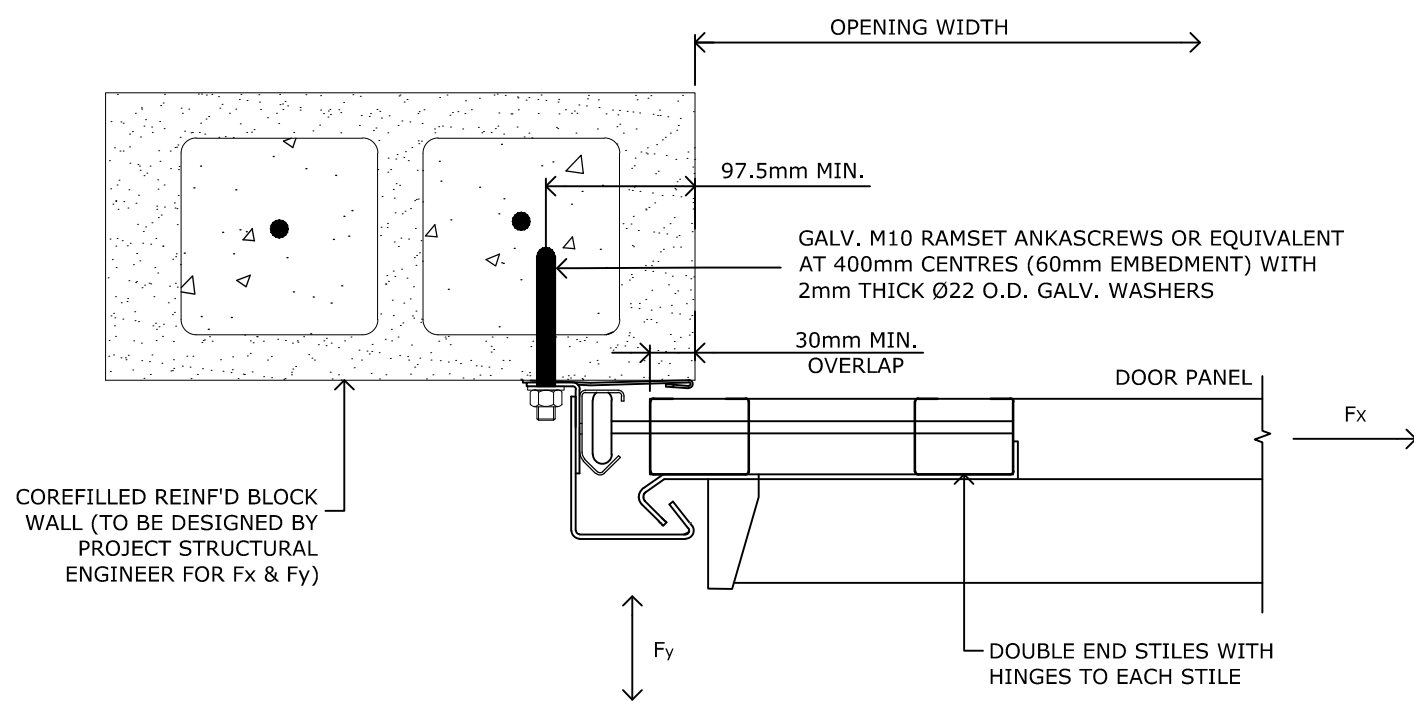

SECTION 1
1:10
PLAN OF TRACK
FIXING TO REINFORCED
COREFILLED BLOCKWORK
ABUTMENT SUPPORTS.

NOTE: $F_y = \frac{Wl}{2}$
WHERE F_y = MAXIMUM OUT OF PLANE ULTIMATE DESIGN ABUTMENT FORCE PER METRE
 W = ULTIMATE DESIGN WIND PRESSURE (kPa)
 L = DOOR WIDTH (SPAN) (m)

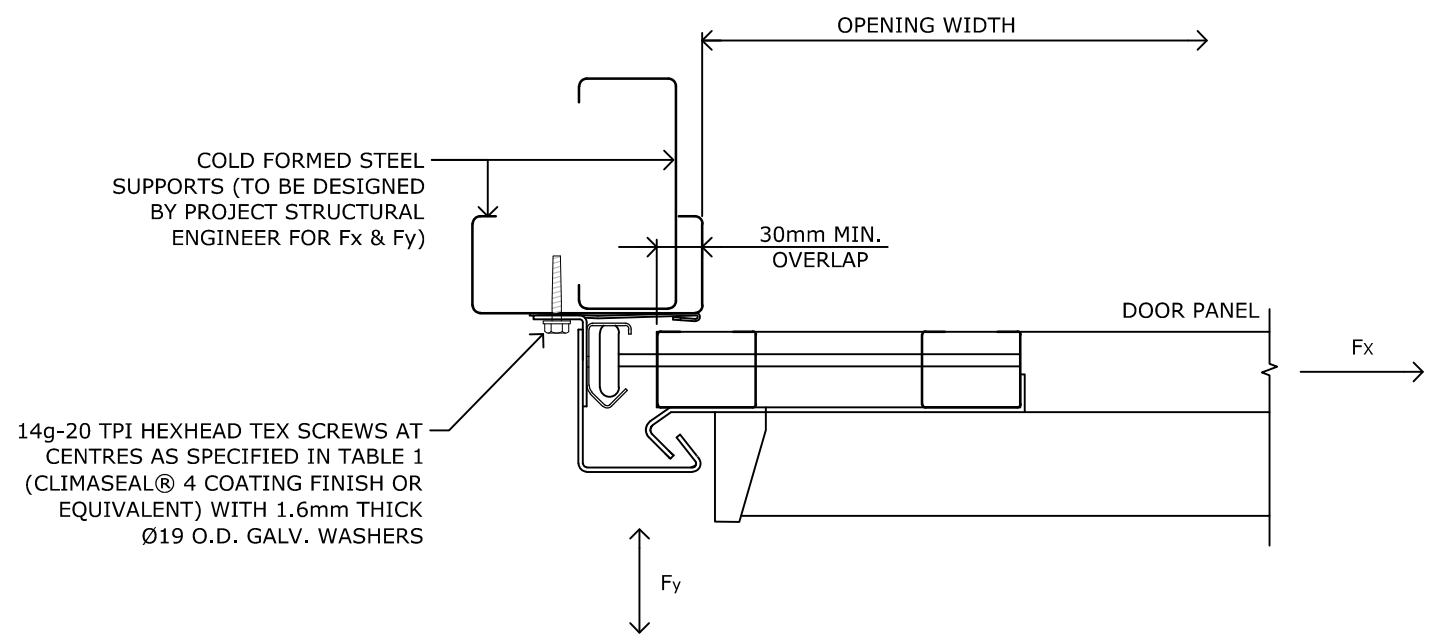

SECTION 1
1:5
PLAN OF TRACK
FIXING TO COLD FORMED
STEEL ABUTMENT SUPPORTS.

NOTE: $F_y = \frac{Wl}{2}$
WHERE F_y = MAXIMUM OUT OF PLANE ULTIMATE DESIGN ABUTMENT FORCE PER METRE
 W = ULTIMATE DESIGN WIND PRESSURE (kPa)
 L = DOOR WIDTH (SPAN) (m)

ISSUE	DATE	AMENDMENTS
B	13.11.15	ISSUED FOR CONSTRUCTION
C	30.03.16	ISSUED FOR CONSTRUCTION
D	04.03.17	ISSUED FOR CONSTRUCTION
E	14.10.21	ISSUED FOR CONSTRUCTION
F	04.04.23	ISSUED FOR CONSTRUCTION

CLIENT	B&D AUSTRALIA PTY LTD
PROJECT	B&D STORM SHIELD HIGH WIND SECTIONAL DOOR

DRAWING SECTIONS

JAMES ELLIS & ASSOCIATES PTY LTD
Consulting Structural Engineers

www.jamesellisengineers.com.au
PO Box 251, Padstow NSW 2211
Ph: 8764 1035

SCALE	DESIGNED J.E.	DRAWING No.	S03 F
DRAWN AAB	CHECKED & APPROVED	PROJECT No.	2422
DATE April 2023			