

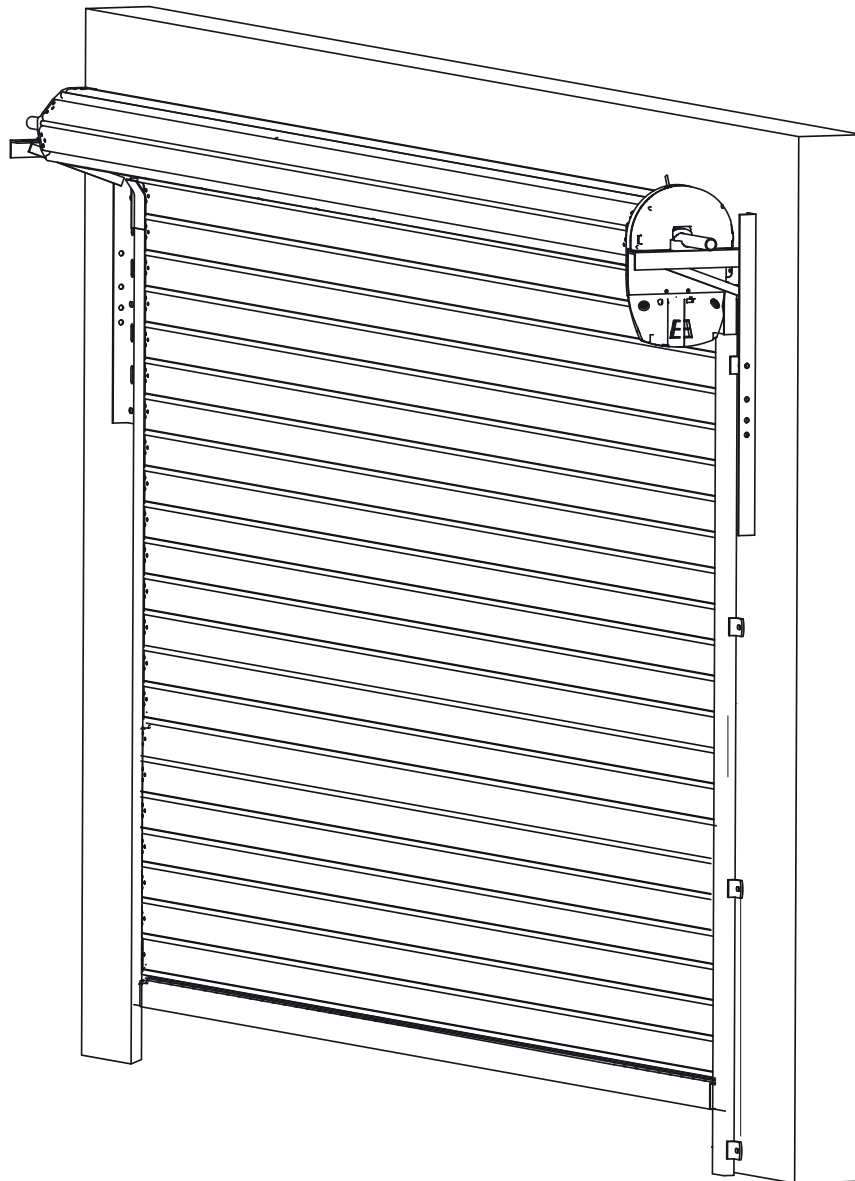

ESY Shutter™

installation instructions



These instructions are intended for professional garage door installers. All references are taken from inside looking out.

DOC# 165023_02
Released: 02/10/23

www.bnd.com.au



contents

1.0 before you start	3		
1.1 safety checklist	3		
1.2 fastener recommendations	5		
1.3 preparation	6		
1.4 before installation	6		
1.4.1 requirements	6		
1.4.2 measurements	6		
1.5 specifications	8		
1.6 parts checklist	9		
2.0 installation	10		
2.1 install first bracket	10		
2.2 install second bracket	10		
2.3 mounting the opener	11		
2.4 position the drum assembly on brackets	11		
2.5 install the guides and safety beams	12		
2.5.1 positioning the guides	12		
2.5.2 positioning the safety beams	12		
2.5.3 mounting the bracket	12		
2.5.4 aligning the transmitter and receiver	13		
2.6 pre-tension the shutter	13		
2.7 checking spring tension	13		
2.8 adjusting spring tension	14		
2.9 final adjustments	14		
2.9.1 final door setup	14		
2.9.2 final automation setup	14		
3.0 automation setup	15		
3.1 setting limits			
3.1.1 limit positions	15		
3.1.2 clearing the shutter limit positions	16		
3.1.3 refilling the shutter	16		
3.2 autoclose	16		
		3.3 safety obstruction force test	17
		3.3.1 testing the close cycle	17
		3.3.2 testing the open cycle	17
		3.4 coding transmitters	17
		3.4.1 transmitter button to operate	17
		3.4.2 erasing programmed codes	18
		3.4.3 selecting the function to code	18
		3.4.4 installing a wall remote control	18
		4.0 operation instructions	19
		4.1 opener safety & security	19
		4.1.1 the shutter CAN NOT be used:	19
		4.1.2 the shutter CAN be used:	19
		4.1.3 to disengage the opener:	19
		4.1.4 to re-engage the opener:	19
		4.2 how to operate the opener	19
		4.2.1 to operate the opener	19
		4.2.2 user operating controls	20
		4.3 shutter status indicators	20
		4.4 troubleshooting guide for opener	21
		5.0 after installation care	22
		5.1 service checklist	22
		5.2 Battery Replacement	23
		5.3 Battery Disposal	23
		5.4 care for your ESY Shutter™	24
		6.0 appendix	25
		A - adjustment mode parameters	25
		B - setting the PET Mode position	26
		C - LED status	26
		D - setting limits via transmitter	27
		E - additional transmitter functions	28
		F - optional extended battery backup	29



1.0 before you start

1.1 safety checklist

This B&D ESY Shutter™ is designed and tested to provide security, attractive appearance and smooth , low effort operation provided it is installed and operated in strict accordance with the following safety warnings. Failure to comply with the following instructions may result in death, serious personal injury or property damage.

NOTE: No guarantee will be given or responsibility accepted by the manufacturers if the shutter is not installed as instructed. The warranty will be null and void if the shutter is installed with any other opener product, other than the GDO-12V2 RAS.

These safety alert symbols indicate a personal safety or property damage instruction exists. **READ THESE INSTRUCTIONS CAREFULLY.**



WARNING!

CRUSH INJURY FROM UNSECURED SHUTTER

- Place a 2 metre exclusion zone around area under the garage opening while installing shutter. If sufficient area is not available DO NOT install shutter.
- Do not move under a shutter while it is on the shutter support (or lifting device).
- Follow the installation instructions.
- Fit shutter support (or lifting device) snugly under shutter before lifting.
- Ensure shutter support (or lifting device) is on flat ground.
- Ensure the shutter is immediately fastened to the bracket with the "U" Bolt.
- Ensure no-one walks under a shutter sitting on brackets.

TENSION SPRINGS

- Ensure shutter is correctly secured at all times when making adjustments.
- Ensure the correct length pipe wrench is utilised.
- Ensure that pipe wrench is fitted correctly to the axle and if it is gripped onto the axle do not underestimate the tension in the spring when undoing the clamps.
- Ensure correct bolts are tightened or loosened to ensure there is no release or controlled release of energy from the spring through the pipe wrench.
- Keep head clear of the pipe wrench at all times.

AUTOMATION OPERATION

- To reduce the risk of injury to persons – Use this operator only with a rolling shutter. The drive must not be used with a shutter incorporating a wicket shutter, unless the drive cannot be operated with the wicket shutter open.
- This operator is a plug in domestic appliance and is designed for shutter use only. It must be installed in a dry position that is protected from the weather.
- The shutter MUST be fitted with safety beams.
- Activate the operator only when the garage shutter is in full view, free of obstructions and with the operator properly adjusted.
- The network device allows for operation of the shutter when not in line-of-sight of the shutter and operator. Therefore the shutter may operate unexpectedly, therefore do not allow anything to stay in or near the path of the shutter.
- Watch the moving shutter and keep people away until the shutter is completely opened or closed.



ELECTROCUTION:

SITE REQUIREMENTS

- Check risk assessment for any highlighted electrical power concerns.
- Ensure power source is isolated prior to commencement of job.
- Turn off electricity to site when necessary.
- Wear rubber soled footwear.

AUTOMATION INSTALLATION

- Check Installation and wiring must be in compliance with your local building and electrical codes.
- This operator is not equipped for permanent wiring. Contact a qualified electrician to install a suitable receptacle if one is not available.
- To reduce the risk of electric shock, this opener has a grounding type plug that has a third (grounding) pin. This plug will only fit into a grounding type outlet. If the plug does not fit into outlet, contact a qualified electrician to install the proper outlet. Do not change the plug in any way.
- If the power cord is damaged, it must be replaced by the manufacturer, its service agent or a similarly qualified person in order to avoid a hazard.
- Connect the power cord only to properly earthed mains. If an extension lead must be used, make sure it is a 3-core lead and approved to 7 amp capacity.
- This unit is not user serviceable. Unplug the power cord before removing the cover. Ensure that the power cord is attached clear of all moving parts. Ignoring these instructions can cause electric shock.





CAUTION:

MUSCULAR STRAIN

- Practice correct lifting techniques when required to lift the shutter.
- Use mechanical aids such as lifting devices, forklift and cranes where possible.
- Avoid twisting.
- Use correct technique of knotted rope installation aids.

FALL FROM LADDER

- Ensure ladder is the correct type for job.
- Ensure ladder is on flat firm ground that will take the weight without the legs sinking.
- Ensure user has 3 points of contact while on ladder.
- Do not work off the top rung.

HAND TOOLS

- Wear appropriate PPE and utilise operators manual of all tools.
- Use appropriate noise/hearing protection in the form of ear plugs or ear muffs.
- Ensure appropriate fire protection available and housekeeping to ensure that flammable liquids or materials are removed from the area of work.

ENTANGLEMENT

- Keep hands and loose clothing clear of moving shutter and guides at all times.
- To avoid serious personal injury from entanglement, remove all unnecessary ropes or chains and disable any equipment such as locks which are not needed for powered operation.
- Do not wear rings, watches or loose clothing while installing or servicing a shutter operator.

AUTOMATION OPERATION

- If your garage has no pedestrian entrance shutter, an emergency access device should be installed. This accessory allows manual operation of the garage shutter from outside in case of power failure.
- Keep the garage shutter balanced. Sticking, binding or shutters with damaged slats must be repaired. Garage shutters, shutter springs, brackets and their hardware are under extreme tension and can cause serious personal injury. Do not attempt any garage shutter adjustment. Do not use if repair or adjustment is needed. Call for professional garage shutter service.
- Position the Garage Shutter Opener so that the power plug is accessible when inserted into the power outlet.
- Install the wall transmitter in a location where the garage shutter is visible, but out of the reach of children at a height of at least 5 feet (1.53m).
- Activate the opener only when the shutter is in full view, free of obstructions and with the opener properly adjusted.
- The opener is not intended for use by young children or infirm persons without supervision.
- Keep transmitters away from children.
- Do not allow children to play with shutter controls.



LACERATION:

- Wear appropriate PPE (Dyneema cut off gloves) and keep hands well clear of pinch points.
- Follow instructions explicitly, particularly for the installation of some parts of the shutters, as the unrolled cut out edges presents a very sharp edge.



TWO PERSON LIFT:

- With the use of a mechanical aid this product requires a two person lift to raise onto the brackets. Use proper techniques and equipment to lift the shutter from the trailer and up onto brackets.



1.2 fastener recommendations for fitting shutters

WARNING! The installer must select and use fasteners appropriate to the material into which they are being fixed.

WARNING! Refer to the weight label on the packaging or the B&D Product Guide to ensure the selected fastener is appropriate.

material	fastener type(s)	diameter or type		length of fastener (see note)	BKT	GUIDE
New Hollow Brick (core filled)	HRD-VGK or HGK-VGS (Hex Head) Frame Anchors	10mm	x	60mm	•	•
New Solid Concrete	Coach Bolts (Hex Lag Screw) - combined with wall plugs	5/16"	x	1½"		•
		3/8"	x	2"	•	•
	Macplugs (wall plugs) to suit above	5/16"	x	50mm		•
		3/8"	x	60mm	•	•
HLC Sleeve Anchors (Dyna Bolts)	12mm	x	55mm	•		
Steel Framing e.g. BHP Framing (with rear access)	Hex Head Bolt Zinc Plated, Hexagon Nuts Zinc Plated, Washers Zinc Plated	5/16"	x	1"		•
		3/8"	x	1"	•	•
		10mm	x	25mm	•	•
		12mm	x	25mm	•	
Heavy Gauge Steel	Hex Head Tek	14-20	x	22mm	•	•

important notes

- a) For installation to materials not covered in the chart, the installer should seek expert advice from a qualified builder.
- b) Minimum length of fastener does not exclude use of longer lengths. Decision must be made by fitter to ensure adequate strength.
- c) Recommendations for old materials or materials not in good condition are not included. If in doubt about the strength of the material seek specialist advice.
- d) Fasteners for brackets in masonry should be at least 5/16" x 2.5" long or metric equivalent.

STEEL CONSTRUCTION

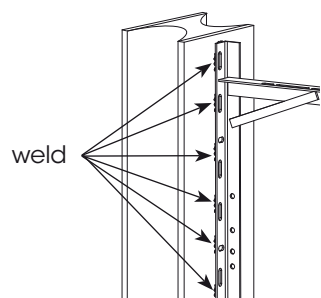

OR

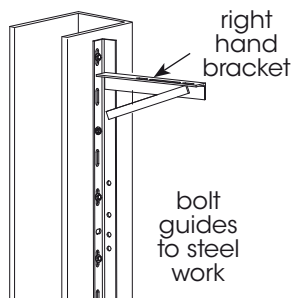

SECURE GUIDE

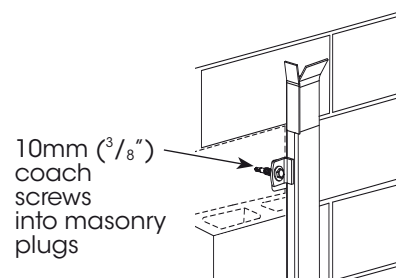

MASONRY BLOCK CONSTRUCTION

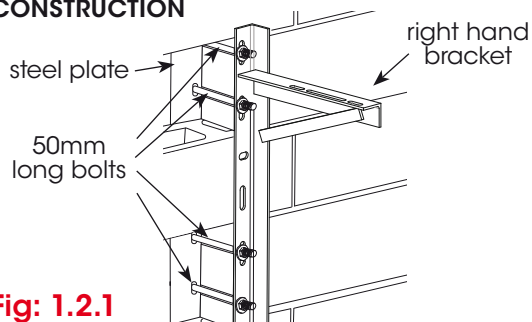

WARNING! Masonry blockwork should be properly filled and reinforced if brackets are to be mounted directly to blockwork with masonry anchors. Where the blockwork is not solidly filled but structurally sound, long bolts should be passed through the blockwork using suitable steel plates under bolt heads. Special consideration should be given to brick type and construction of wall, to ensure satisfactory fixing e.g. welding detail if fixed to steel.

Fig: 1.2.1

1.3 preparation



WARNING! If you need to remove an old shutter prior to installing a B&D shutter ensure to:

- Roll the curtain up and secure curtain around the middle.
- Use correct lifting techniques and machinery.
- Fit machinery snugly under shutter before loosening the brackets or locating U bolts.
- Slowly undo bolts to release the spring tension and the shutter from the brackets.
- Slowly lift the shutter from the brackets keeping it balanced as it is lowered to the ground.

1.4 before installation

1.4.1 requirements

mounting - The shutter is designed to be mounted behind the opening.

obstructions - Ensure that the surface where the shutter will be fitted is flush and smooth, and the area behind the opening is free from any protrusions.

structural suitability - Ensure the opening is strong enough to support the shutter. If unsure, consult a builder.

level and plumb - The shutter must be installed in an absolutely level position, if opening is not level and square, appearance and/or sideroom requirements will be affected. The floor should be level or recessed across the opening to avoid gaps.

power supply - The opener must be connected to a properly earthed 3 pin single-phase power supply.



WARNING! Using a portable power generator is not recommended. The opener may appear to malfunction due to spikes, surges and fluctuations in the generated voltage.

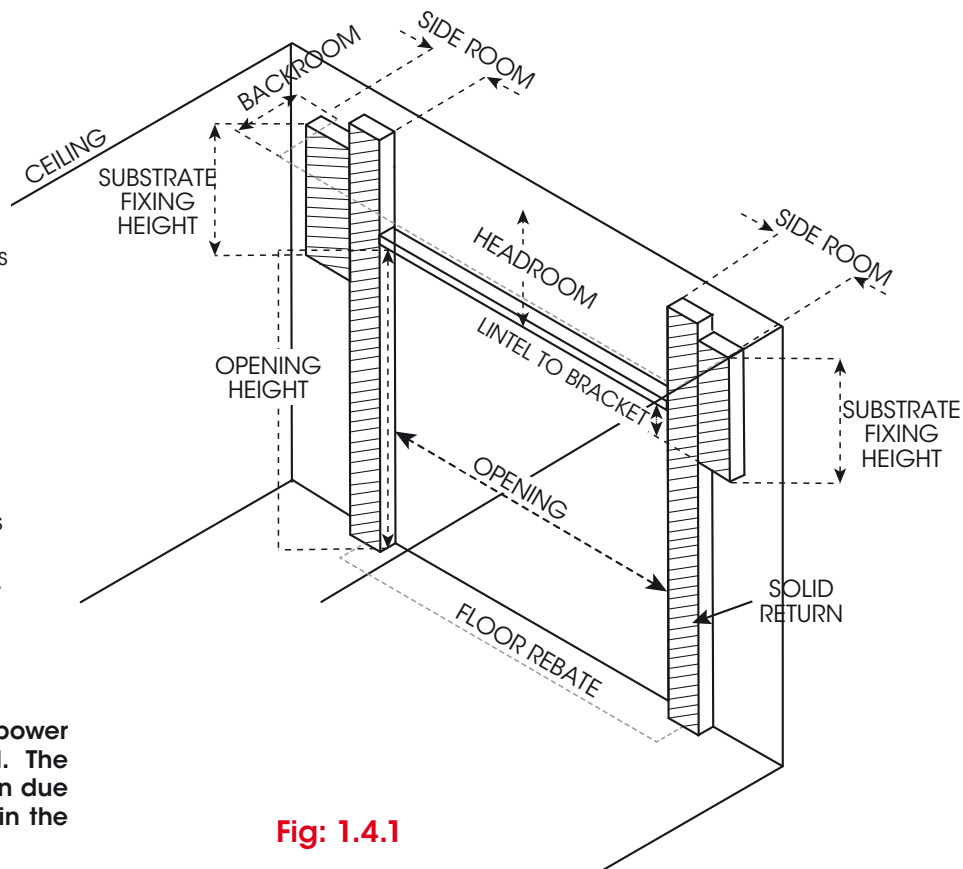

Fig: 1.4.1

1.4.2 measurements

opening width - Check the width of the curtain with the width of the opening and ensure that when the fixing holes in the curtain are lined up with the fixing studs on the drum, the curtain overlaps on each side of the opening by 70mm, therefore shutter curtain, including clips should be 140mm wider. **(Fig 1.4.1)** Position the drum in front of the opening so that the drum tube (excluding the gear wheel) is exactly in the centre of the opening.

opening height - The shutter opening height indicates the distance between the ground and rubber seal at the bottom of the shutter, with shutter fully open.

headroom - A minimum headroom is required for all shutters. Refer to **Fig 1.4.2 - 1.4.3** for measurements. If the shutter is installed lower into the opening than shown in Fig 1.4.2, additional loss of shutter opening height will result.

backroom - A minimum of 700mm of backroom is required for ESY Shutters. Extra room would be required for installing large shutters.

side room - A minimum of 220mm of side room piers or shutter posts must extend beyond the top of the opening to provide fixing for the support brackets



1.4.2 measurements continued...

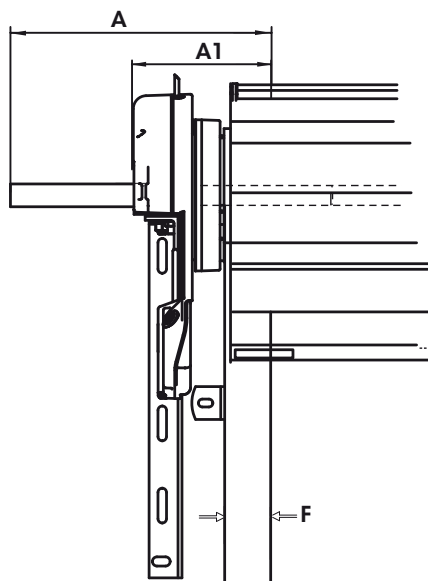

Fig: 1.4.2

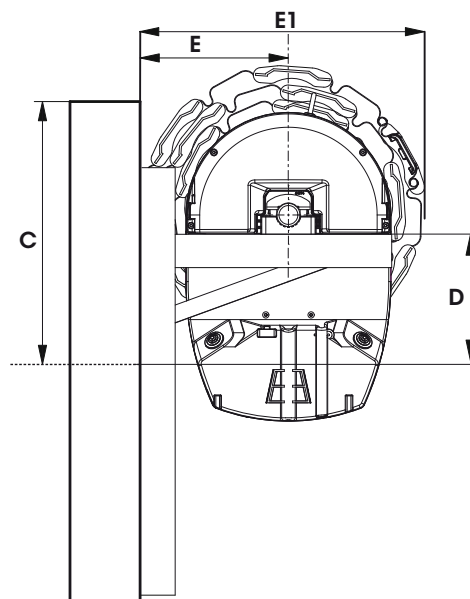
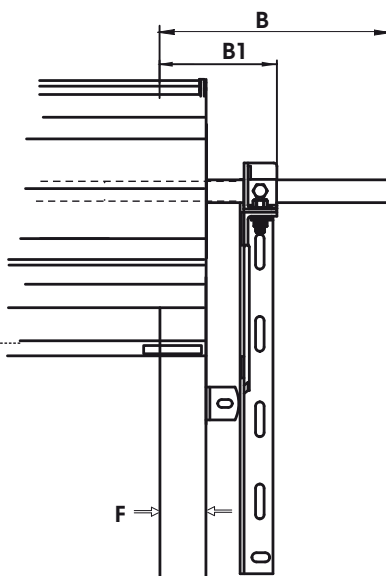

Fig: 1.4.3

dimension table												
Door Model Code	Door height (mm)	Door width (mm)	Drum Size	Minimum Sideroom Opener Side		Minimum Sideroom Plain Side		Recommended Headroom	Lintel to bracket	Recommended Backroom		Width of Guide
				Axle	Opener	Axle	Bracket			Axle to Wall	Curtain	
				A	A1	B	B1			C	D	
RASE	up to 2000	up to 4300	8'	330	240	330	180	660	405	260	700	77
	2001 - 3000							696	423	278		
	3001 - 4000							710	430	285		
	4001 - 4600							754	452	307		



WARNING! No guarantee will be given or responsibility accepted by the manufacturers if the shutter and opener are not installed as instructed.

For satisfactory shutter operation please follow the instructions carefully.



CAUTION: Opener adaptor is factory fitted to specified side at time of order. Therefore there is only one side the opener can be fitted to.

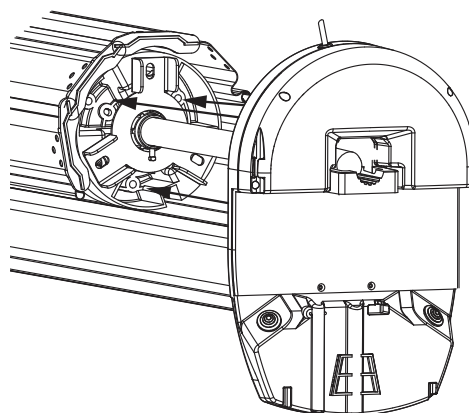

MW* = mounting weight of curtain/drum assembly

height	width							
	2100	2500	2800	3100	3400	3700	4000	4300
	MW*	MW*	MW*	MW*	MW*	MW*	MW*	MW*
2100	147	172	191	210	229	248	267	286
2500	155	182	202	222	242	262	282	302
2800	162	189	210	231	252	273	293	314
3100	168	197	218	240	261	283	305	326
3400	174	204	227	249	271	294	316	338
3700	181	212	235	258	281	304	327	350
4000	187	219	243	267	291	315	339	362
4300	194	226	251	276	301	325	350	375
4600	199	233	259	284	310	335	361	386



CRANE LIFT: this product requires proper techniques and equipment to raise the shutter up and onto the brackets. Refer to mounting weight table for crane lifting capacity.



1.5 specifications

Shutter must be well balanced and able to be operated by hand, as per warranty conditions and standard AS/NZS 4505:2012

Shutter Technical Specifications	ESY Shutter™ (RASE)	Opener Technical Specifications	GDO-12RAS Hiro (GDO-12V2RAS)
Drum Type:	Welded spiral steel tube (raw finish) w/ polymer drums	Rated voltage range	230V - 240V
Axle:	33.7 OD x 4mmT	Rated frequency	50Hz / 60Hz
Spring:	Helical torsion spring (15,000 cycle life)	Rated power input	150W
Axle Wall Brackets:	Welded 50m x 50m x 5m angle steel (dacromat coated)	Rated operating time:	6 min
Type of shutter: Max Shutter Height: Max Shutter Width:	Sprung Shutter 4600mm 4300mm	Rated operating temperature	-10 °C to +55 °C
Balanced Door Weight	20kg	Rated load	500N
Curtain details: Slat Type: Slat Clips:	Galvanised Steel 6/100 (0.6mm) Nylon clip	Type of shutter: Max curtain weight:	ESY Shutter 270kg ¹
Bottom Rail	Aluminium extruded T section bottom rail with weather seal	IP rating	IP20
Guides	Standard 77mm Galvanised Steel guides	Receiver type	Multi-frequency UHF
Operation	Automated by GDO-12RAS	Receiver code storage capacity	64 x 4-button Transmitters
Optional Locking (Not recommended)	Internal & External Slide Bolt	Transmitter battery	CR2032 (3 Volts)
		Courtesy light	LED (Light Emitting Diodes)
		Battery Backup	1.2aH/24V - 3 ²
		Manual Engage / Disengage	Pull action on cord to engage / disengage manual operation
		Monitored Wired Safety Beam	Standard safety device for obstruction detection ³
		Auto-Close	Includes programmable time
		Travel Speed	Adjustable speeds
		Network connectivity	Requires optional (Smart Phone control Kit)

1. Gross curtain weight, incl all fittings. Does not include drum weight.
2. Cycles in a 2hr period when mains not available. One cycle is a complete open and close.
NOTE: Optional 5.0aH battery pack available for higher capacity.
3. Opener functions are disabled if Safety Beams are not installed.



1.6 parts checklist

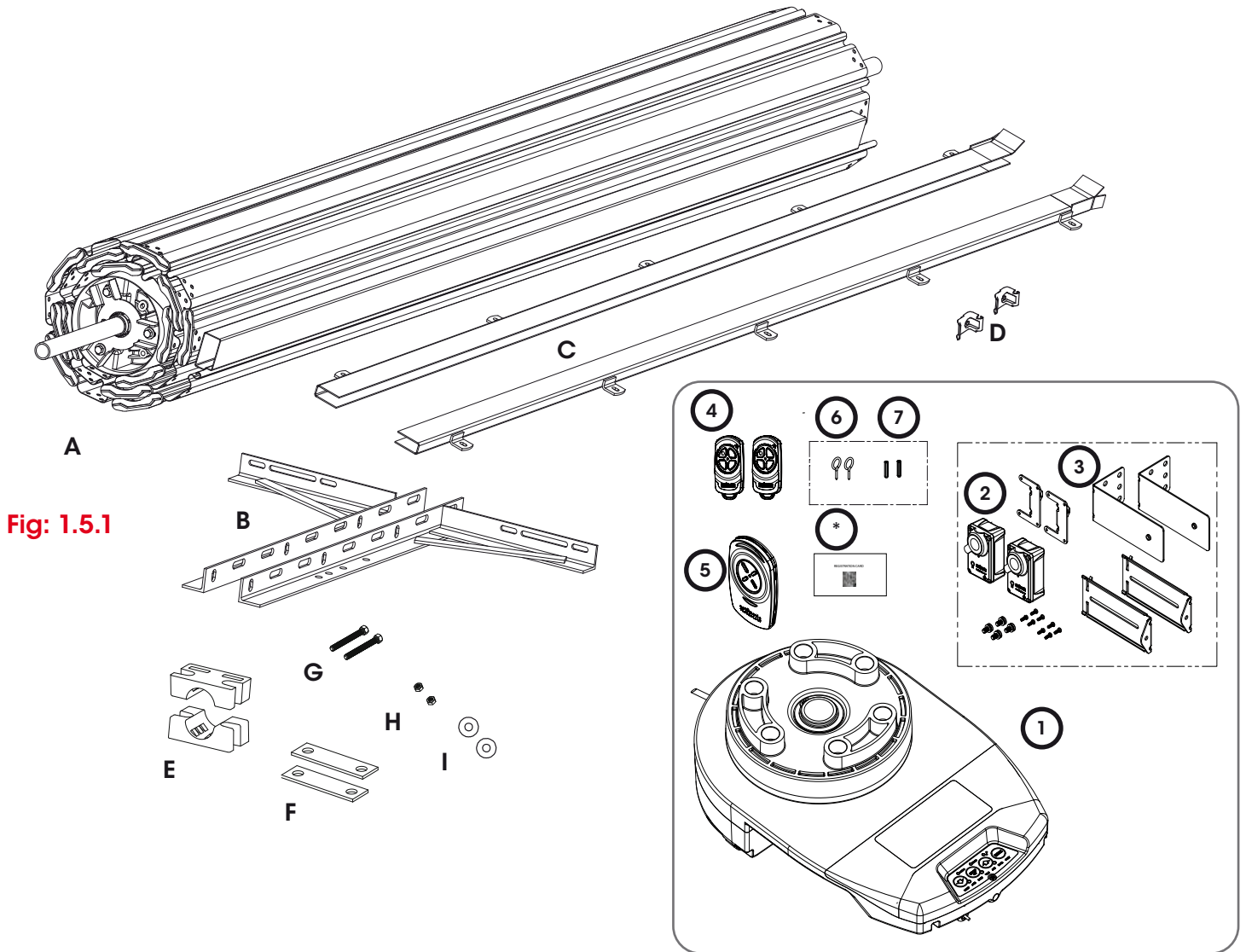

Fig: 1.5.1

ESY SHUTTER		RASE
ITEM	DESCRIPTION	QTY
A	ROLLED SHUTTER	1
B	BRACKETS, LEFT AND RIGHT HANDED	2
C	SHUTTER GUIDES LEFT AND RIGHT HANDED	2
SMALL PARTS BAG CONTAINING		
D	BOTTOM RAIL STOPS AND SCREWS	2
E	SADDLE KITS INDUSTRIAL	1
F	SADDLE PLATES INDUSTRIAL	2
G	BOLT 3/8" X 3 1/2" HT HEX HD ZP	2
H	NUT HEX 3/8" UNC ST ZP	2
I	WASHER FLAT M10 ZP	2

GDO-12RAS HIRO OPENER		GDO-12V2RAS
ITEM	DESCRIPTION	QTY
1	GDO-12 DRIVE UNIT	1
2	WIRED PE3V1 EASYBEAM	2
3	PE BEAM MOUNTING KIT	2
4	4 BUTTON TRANSMITTERS	2
5	4 BUTTON WALL TRANSMITTER	1
GUIDE PACK VR12		
6	SCREW-EYE	2
7	PLASTIC WALL PLUG 6.9 X 25 (1")	2
* REGISTRATION CARD (Please retain for optional smart phone control kit)		

2.0 installation

2.1 install first bracket

dimension table						
	height (mm)	width (mm)	A1	B1	C	D
RASE	up to 2000	up to 4300	240	180	660	405
	2001 - 3000				696	423
	3001 - 4000				710	430
	4001 - 4600				754	452

Fig: 2.1.1

- Use above diagrams **Fig 2.1.1** and **2.1.2** for head and sideroom clearances.
- Mark three hole positions using slots of the bracket **(B)**.
- Drill holes, then attach bracket using six 10mm (3/8") bolt size masonry anchors; (dynabolts or similar).

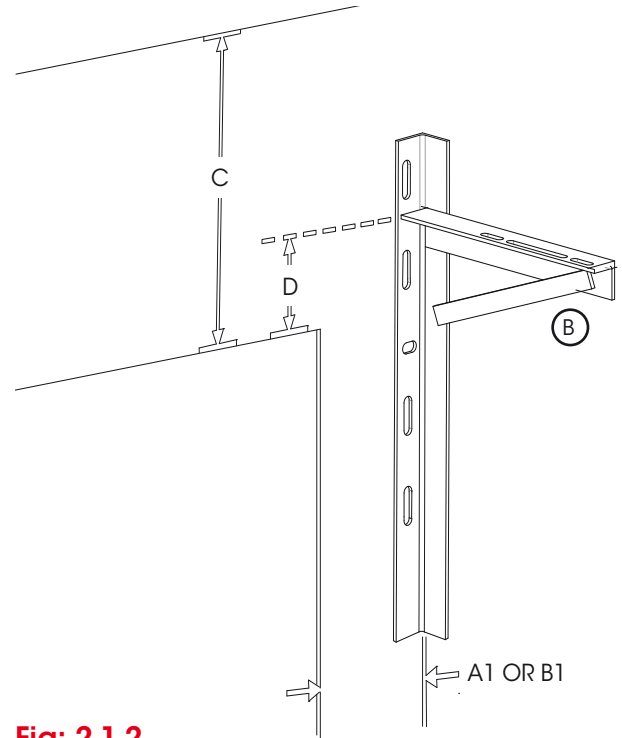

Fig: 2.1.2

2.2 install second bracket

- Using a laser level or water level, mark the position for the second bracket (**Fig 2.2.1**)
- Re-check levels then drill and fix as with first bracket.

CAUTION: The brackets must be perfectly level for the shutter to operate.

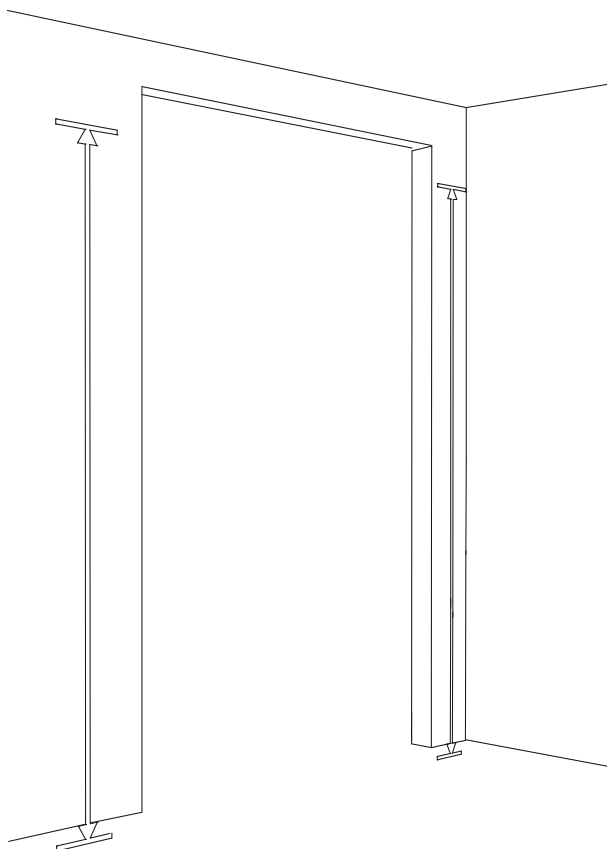

Fig: 2.2.1



2.3 mounting the opener

- a) Carefully raise the shutter off the ground to waist height, ensuring the drum is balanced.
- b) Open the opener box and check the drive gear rotates freely, by pulling the string handle down (there will be a click) to disengage opener. Then move the forks from side to side by hand.
- c) Loosen the U-bolt and slide the opener ① over the shutter axle and into the drum of the shutter as shown in **Fig 2.3.1a**.
- d) Ensure the internal gear is pushed in as far as possible (without interfering with the shutter curtain) and that the shutter drum's outer wheel spokes are completely between the opener's drive forks.
- e) Loosely tighten the U-bolt around the axle as shown in **Fig 2.3.1b** so the axle can still move.

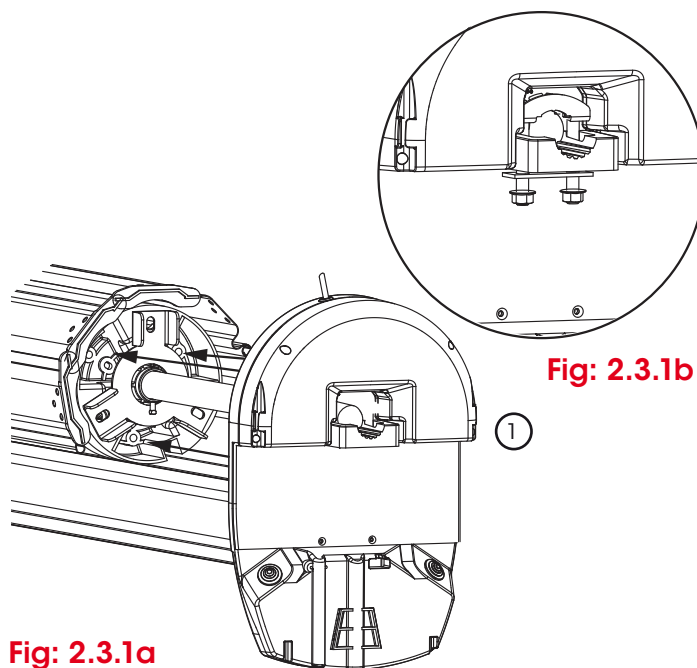

Fig: 2.3.1a

Fig: 2.3.1b

2.4 position the drum assembly on brackets



TWO PERSON: this product requires two persons to secure onto the brackets. Use proper techniques and equipment to raise the shutter up and onto the brackets. Refer to weights table in **section 1.4.2** for equipment lifting capacity.



CAUTION: DO NOT UNTIE THE CURTAIN YET

- a) Check the axle length and cut if sideroom is limited.
- b) With the shutter the correct way round (the curtain rolls down the rear of the opening) carefully lift shutter onto the brackets using suitable lifting equipment – to avoid curtain and or opener damage.
- c) Referring to **Fig 2.4.1** position the saddle plate ⑥ and bottom saddle ⑤ on the bracket ③ to non-opener end, so that the middle is the distance **E** in the dimension table from the wall. Secure top saddle ⑤ and saddle plate ⑥ with bolts ⑦, nuts ⑧ and washers ⑨.
- d) Raise the curtain slowly and rest the axle onto saddle. Before tightening the bolts, ensure the shutter evenly overlaps the opening on both sides and the bottom rail is able to pass the lintel when the shutter is rotated.
- e) Rotate both drum and axle so that the bottom rail is level with the bracket arm or at 9 o'clock. Tighten the saddle bolts evenly, ensuring that there are washers under the nuts, to a torque of 40Nm or 30 ft.lb.
- f) Tighten the U-Bolt screws evenly on the opener, to a torque of 40Nm or 30 ft.lb.

dimension table			
	height (mm)	width (mm)	E
RASE	up to 2000	up to 4300	230
	2001 - 3000		248
	3001 - 4000		255
	4001 - 4600		277



WARNING: The axle must be securely clamped otherwise the shutter will lose tension.

- g) Connect the power cord on the opener to a suitable power point, but DO NOT switch on.
- h) Secure the power cord away from any moving object (eg. the shutter) with a screw eye ⑥ and wall plug ⑦.



CAUTION: If the manual release handle on the opener is more than 1.8metres from floor level, adjust the handle to a height less than 1.8 metres.

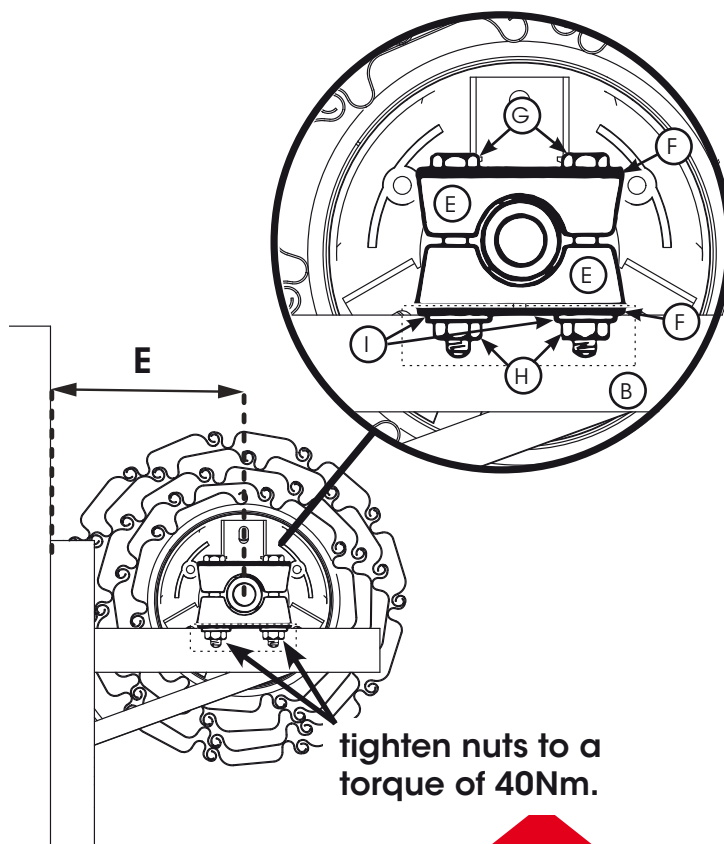

tighten nuts to a torque of 40Nm.

Fig: 2.4.1



2.5 install the guides and safety beams

2.5.1 positioning the guides

Guides must be correct length. The guide stop should be water level and in line with the bottom of the lintel for aluminum bottom rail installation. Guides can be shortened by cutting the bottom of guide.

- Position guides © true and plumb at each side of the opening. Allow 3-5 mm of working clearance between the shutter and the inside of each guide as per Fig 2.5.1.
- Using the guides brackets as a template mark out and drill holes in the wall to match the spacing of the fixing bolt holes in the guides bracket.
- Mark, drill holes and loosely fix the first guide. Select the appropriate fixing as per Section 1.2.
- Using a laser level, transfer position of top of first guide arm to opposite side of opening, then mark, drill and fix second guide. Ensure that the guides are secure.

CAUTION: The guides must be perfectly plumb and level for correct shutter operation.

tip **HELPFUL TIP:** Lightly grease the guides with general purpose grease prior to operating.

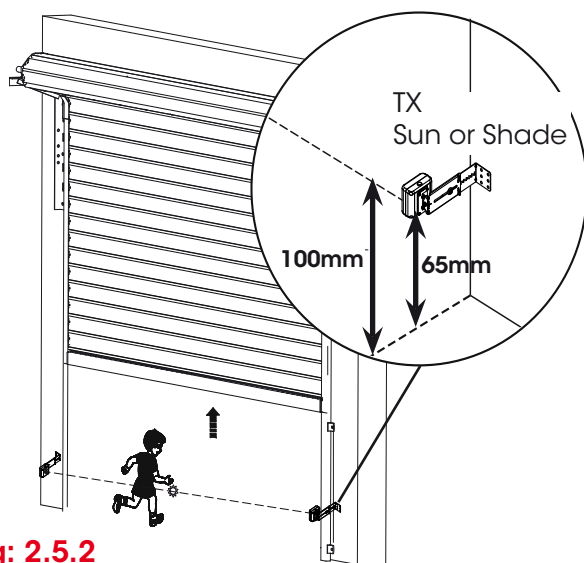

Fig: 2.5.2

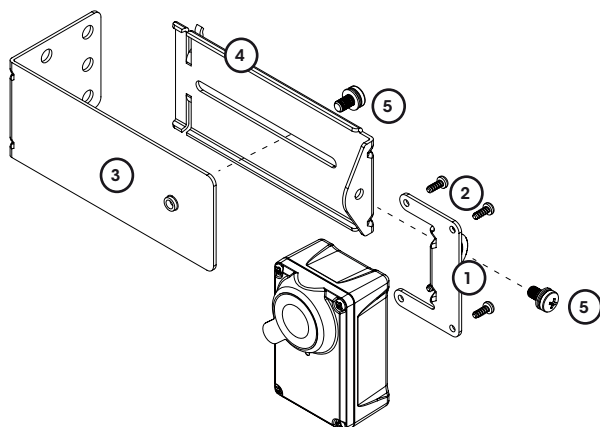

Fig: 2.5.3

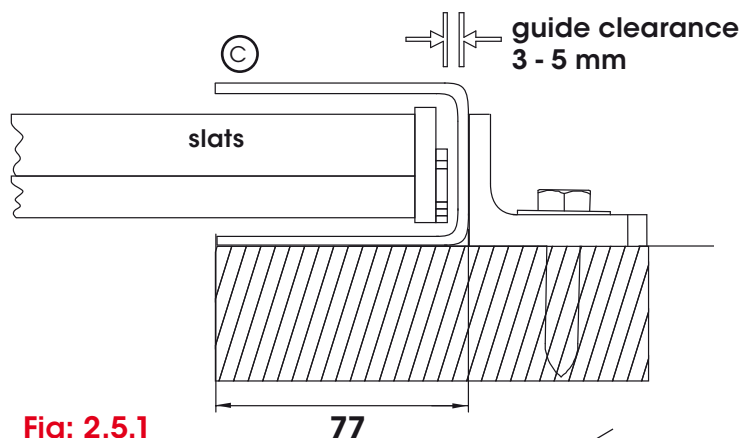
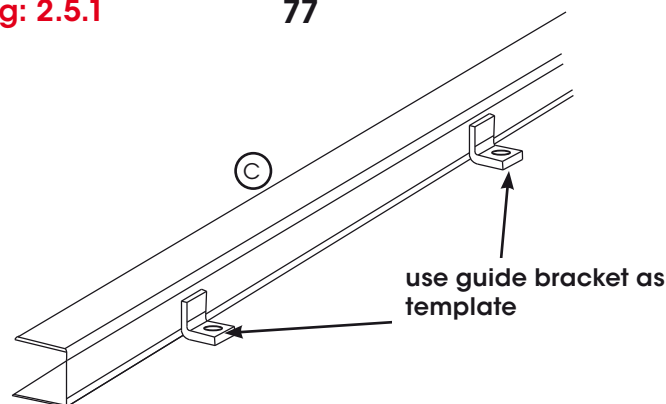

Fig: 2.5.1



2.5.2 positioning the safety beams

WARNING! It is compulsory to have Safety Beams installed to operate the GDO-12RAS Hiro opener.

The Safety Beam Kit provides additional safety by preventing the shutter closing when the beam is blocked by a car, child etc. Without the Safety Beam Kit installed the GDO-12RAS Hiro opener will **NOT** operate. The Auto-close feature can be enabled if required.

The transmitter and receiver need to be placed in line of sight, with the beam 100mm above the ground level (as per AS/NZS 60335-2-95:2012 Amendment 2:2018). This can be achieved by ensuring the bottom of the receiver and transmitter are 65mm above ground level. They should also be placed as close as possible to the shutter opening with the receiver (RX) in shade and the transmitter (TX) in sun or shade (Fig. 2.5.2).

2.5.3 mounting the bracket

- Attach the bracket ① to the Safety Beam Transmitter (TX) using four (4) M3 x 5 Taptite screws ② (Fig. 2.5.3).
- Connect the mounting bracket ③ to the adjustment bracket ④ with a M5 x 10 pan head screw ⑤.
- Affix the bracket ① with safety beam to the adjustment bracket with the remaining M5 x 10 pan head screw ⑤.
- Repeat steps (a) and (b) to assemble the Safety Beam Receiver (RX).
- Locate the each Safety Beam bracket next to the shutter guide, ensuring the bottom of the receiver and transmitter are 65mm above ground level as per (Fig. 2.5.2). The mounting surface should be rigid.



2.5.4 aligning the transmitter and receiver

- a) Wire the PE Beams as per Wiring Diagram (Fig. 2.5.4).
- b) Power up the opener with the safety beams connected. The green LED on the transmitter should turn ON to indicate power is present.
- c) If the receiver is connected to power and the red LED is flashing while the green LED on the transmitter is on, the transmitter and receiver are not aligned.
- d) Make horizontal and/or vertical adjustment on the transmitter and/or the receiver (Fig 2.5.5) until the red LED on the receiver turns on, indicating alignment.

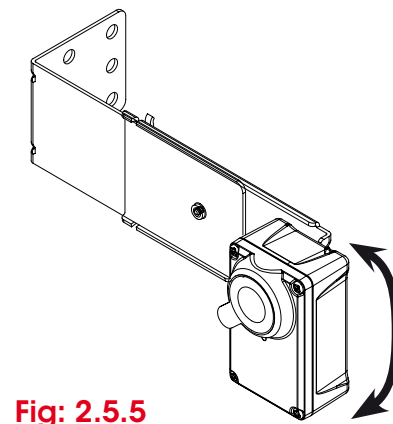
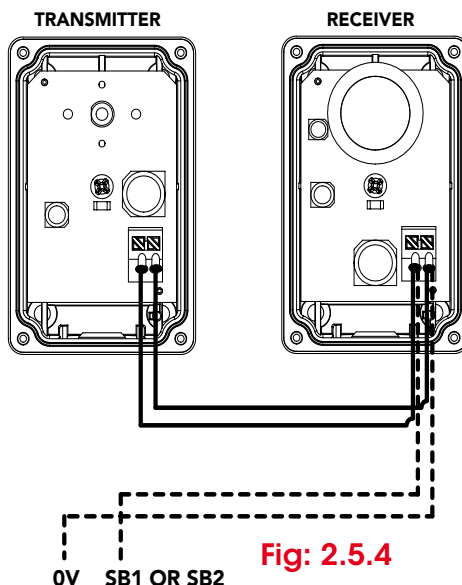

2.6 pre-tension the shutter

Tension the shutter counterbalance springs in the following manner:

- a) Rotate the door approximately **2 complete** turns in a forward direction to apply spring pre-tension (Fig 2.6.1)
- b) When satisfied, pull the disengagement cord on the opener to lock the door.

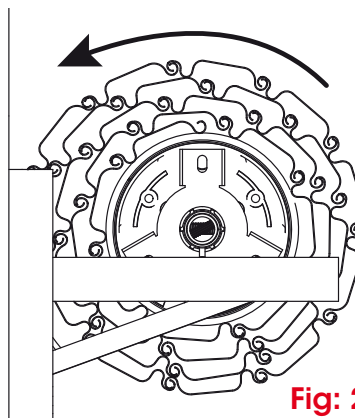

WARNING! Check the opener is engaged. The door should not be able to move.

- c) Carefully remove the straps holding the bundled roll, disengage opener and lower bottom rail into the guides.

WARNING! When the bands holding the shutter curtain rolled up are cut, there will be a strong tendency to rise and revolve. If uncontrolled, the rapidly unrolling shutter could cause damage or injury.

- d) Fit bottom rail stops (D) using self locking nuts provided. Allow the door to rise and rest against the head stop (Fig 2.6.2)

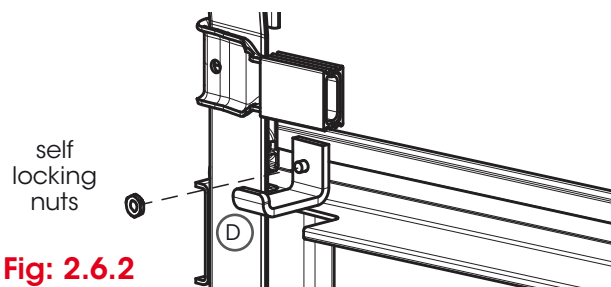

2.7 checking spring tension

WARNING! Only use the OPEN and CLOSE Buttons during this setup. DO NOT set limits at this point.

- a) Switch power on, engage the opener and press and hold the BLUE CLOSE button the move the shutter all the way to the floor.

HELPFUL TIP: If the shutter moves in opposite direction, press and hold the OPEN and CLOSE buttons at the same time (approx 3 seconds) until you hear a beep. This will reverse the direction of the motor.

- b) Disengage the opener and check the door balance, by manually raising and lowering the door.

WARNING! A balanced shutter should not weigh more than 40kg in manual operation. Please ensure proper lifting techniques are used when manually operating the shutter.

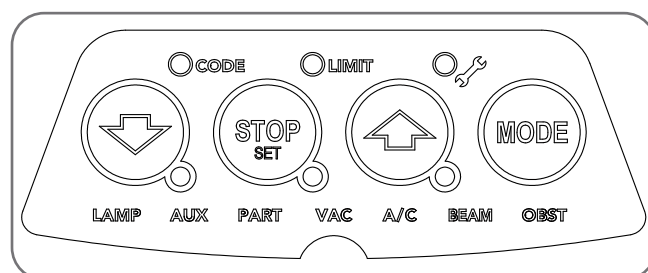

- c) Manually move the door to 1 metre from the floor. and check door balance.

- d) If adjustments are required, raise door to the open position by reengaging the opener and follow Section 2.8.

2.8 adjusting spring tension

WARNING! Ensure that pipe wrench is fitted correctly to the axle and if it is gripped onto the axle do not underestimate the tension in the spring when undoing the clamps.

CAUTION: THIS ADJUSTMENT REQUIRES 2 PERSONS TO COMPLETE.

- Raise door to the fully open position using the GREEN OPEN button on the opener.
- With a person at each end of the shutter, hold the axle firmly with a large pipe wrench (Stillson) at least 450mm long.
- Loosen the axle nuts at both ends and **KEEP A FIRM GRIP ON WRENCH.**
- Rotate the axle in the required direction (**Fig 2.8.1**).
- Re-tighten the axle nuts to a tension of 40 Newton metres or 30 ft.lbs **BEFORE** releasing pipe wrench.
- To Test, repeat steps in 2.7.1. if further adjustment is necessary repeat steps above.

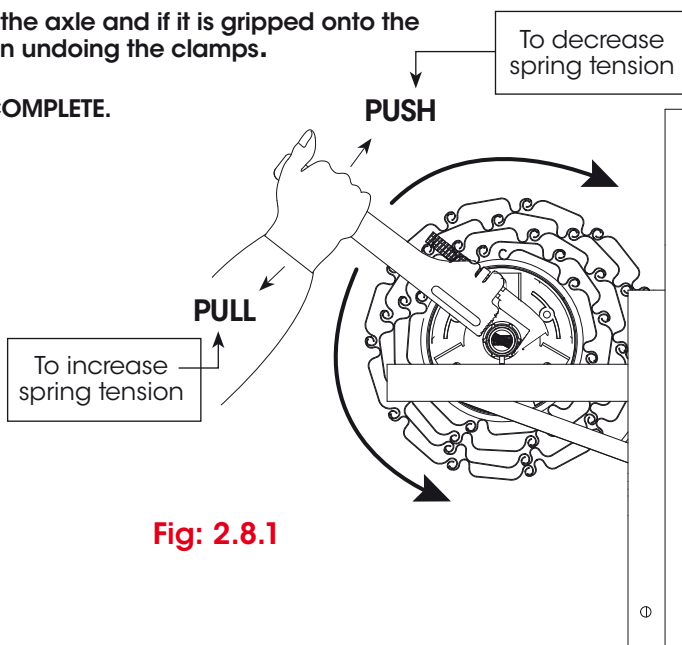

Fig: 2.8.1

2.9 final adjustments

2.9.1 final door setup

Operate the shutter up and down a number of times with the opener to check operation. If operation is uneven or not smooth, rectify as below:

Symptom	Possible cause	Remedy
Shutter is hard to operate in ANY DIRECTION	Shutter jamming in the guides	Check: a) the guide clearances b) the guides are plumb c) that the guide surfaces are clean and free from oil d) ensure guides are lightly greased with general purpose grease
The shutter is hard to operate in ONE DIRECTION	The spring tension requires adjustment	a) if the shutter is hard to lift, but tends to drop, refer to section 2.8 to increase the spring tension b) if the shutter is hard to close, but tends to rise, refer to section 2.8 to decrease the spring tension
Shutter stiff to work and rattles over lead-in on top of guides	Guide are too long	Check the guide clearances
	Shutter too far from lintel	Refer to section 2.4 and ensure shutter is positioned correctly as per table.
Shutter scraping in the guides	Brackets are not level	Make sure brackets are level, refer to step 2.2.
	Guides are not plumb	Make sure the guides are plumb, refer to step 2.5.

2.9.2 final automation setup

- Mount battery backup pack ① onto support chassis by sliding down over the slots. Connect the coupling wire to the battery as shown (**Fig 2.9.1**).

WARNING! After Step (b) the opener may become active (even when power is off). This is a result of a residual charge in the batteries.

- Connect battery harness ② plug through opening to control board.

WARNING! Secure the manual release handle and string with the accessory supplied, so that the string is away from moving parts.

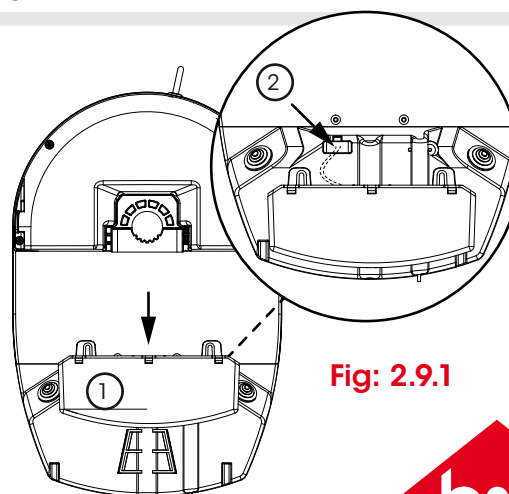

Fig: 2.9.1







3.0 automation setup

3.1 setting limits





3.1.1 limit positions



SETTING LIMITS

tip When setting the Close limit, ensure the position is when the door makes first contact with the ground. Alternatively for the Open limit the position should be at the height of the garage opening.





STEP ONE	STEP TWO
   <p>Switch power on. BLUE LED will flash</p>	 <p>To move the door to the halfway point.</p>



CLOSE LIMIT POSITION





STEP ONE	STEP TWO
  <p>HOLD</p> <p>Take note of the speed as door moves</p>	<p>If Close speed not suitable, release button, THEN</p>    <p>HOLD</p> <p>Each press changes speed as per table</p>





BEEPER	SPEED MODE
3 x 	FAST (Default)
2 x 	MEDIUM
1 x 	SLOW

OPEN LIMIT POSITION

STEP ONE	STEP TWO
  <p>HOLD</p> <p>Take note of the speed as door moves</p>	<p>If Open speed not suitable, RELEASE button, THEN</p>    <p>HOLD</p> <p>Each press changes speed as per table</p>

BEEPER	SPEED MODE
3 x 	FAST (Default)
2 x 	MEDIUM
1 x 	SLOW

STEP THREE	STEP FOUR
   <p>RELEASE HOLD</p> <p>When at desired speed Press to close door</p>	 <p>When door near close, single presses inch door</p> <p>CLOSE limit should be when rubber strip touches the ground</p>

STEP THREE	STEP FOUR
   <p>RELEASE HOLD</p> <p>When at desired speed Press to open door</p>	 <p>When door near open, single presses inch door</p> <p>OPEN limit should be the height of the garage opening</p>

WARNING! In setting the close limit position, do not force the door into the floor. Once the bottom rail touches the floor, set the Limit. No more than 2 -3 slats should be compressed. Failure to do so will interfere with the operation of the manual release mechanism.

WARNING! The door will automatically close. open and close again after the next step. Ensure that nothing is in the door's path.

STEP FIVE

If door overshoots







Press Press to position Press to set

STEP FIVE

If door overshoots













Press Press to position Press to set

Door will open & close to calculate safety obstruction settings

NOTE: If unhappy with the speed or travel limit setting, restart this procedure by clearing the shutter limit positions as per below first.

3.1.2 clearing the shutter limit positions

STEP ONE	STEP TWO
 Switch power OFF	   Switch power ON
STEP THREE	
 LIMIT LED will flash	 SET Close & Open limits

tip **HELPFUL TIP:** Alternatively set travel limits using a transmitter, allowing free movement around the garage to better assess the desired limit positions. See Appendix D.

tip **HELPFUL TIP:** The shutter can be set to a partial open position and programmed to a transmitter button. Refer to Appendix B.

3.2 autoclose

Auto-Close mode is a function that automatically closes the shutter after a pre-set time. There are two types of Auto-Close available:







- (i) Standard auto-close - the shutter will Auto-Close after a programmed time. In this mode the timer starts to countdown as soon as the shutter is fully open. This function is useful in case the safety beam does not get triggered.
- (ii) Safety Beam triggered auto-close - the shutter will auto-close after a programmed time. In this mode the timer starts counting down only when the safety beam is triggered. ie car leaving the garage.

WARNING! It is compulsory to have Safety Beams installed to operate the opener.















3.1.3 reprofiling the shutter

tip Re-profiling is a simple way of re-learning the travel characteristics of a previously setup Limit Switch travel. Re-profiling is used when travel characteristic change due to mechanical adjustments.

To initiate a re-profile: LIMITS must already be set.

STEP ONE	STEP TWO
Remove controls cover  Press repeatedly	  till LIMIT LED lit
STEP THREE	
 Press repeatedly	  till OBST LED lit
 HOLD for 2 secs	The shutter will open and close by itself to record profile

TO ENABLE THE AUTO-CLOSE FUNCTION

STEP ONE		
Remove controls cover  Press repeatedly	  till Spanner LED is lit	  One of the word LED's will light up
STEP TWO	STEP THREE	
 Press repeatedly	  till A/C LED lit	 Press x 2 PE Auto x 3 Std Auto
 Press to enter parameter		
STEP FOUR		
 Press to move through options as per table	  Press to save	OR  Press to leave unchanged

LED Indicators	Parameter	OPEN	OPEN & STOP	STOP	CLOSE & STOP	CLOSE
A/C LED	A/C Function	90s	60s	30s	15s	OFF
A/C & BEAM LED'S	PE A/C Function	60s	30s	15s	5s	OFF

3.3 safety obstruction force test

WARNING! Take care when testing or adjusting the Safety Obstruction Force. Excessive force may cause **SERIOUS PERSONAL INJURY** and/or **PROPERTY DAMAGE**.

WARNING! If the shutter fails these tests, put the opener into manual mode, only operate the shutter by hand and call for service.

3.3.1 testing the close cycle

- Press the OPEN button to open the shutter.
- Place a piece of timber approximately 40mm high on the floor directly under the shutter (**Fig. 3.3.1**).
- Press the CLOSE button to close the shutter. The shutter should strike the object and start to re-open.

3.3.2 testing the open cycle

- Press the CLOSE button to close the shutter.
- Press the OPEN button to open the shutter. When the shutter reaches the half open point, grab the bottom rail of the shutter firmly and the shutter should stop.
- If the shutter does not reverse readily when closing, or stop when opening, the force may be excessive and need adjusting.

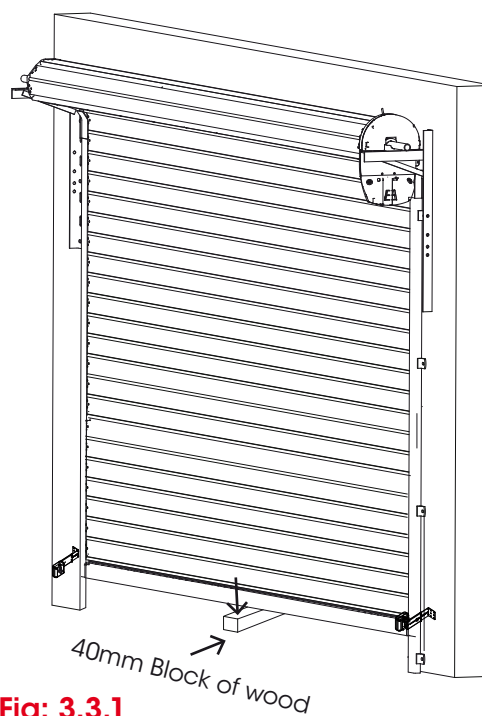

Fig: 3.3.1

3.4 coding transmitters

3.4.1 transmitter button to operate shutter

tip The opener can only be operated from remote controllers that have been programmed into its memory. Up to 64 remotes can be programmed.

STEP ONE	STEP TWO
<p>remove controls cover</p>	<p>Press repeatedly till CODE LED is lit</p>
STEP THREE	
<p>Press repeatedly</p>	<p>till all three LED's are lit</p>
STEP FOUR	STEP FIVE
<p>HOLD to enter coding</p> <p>HOLD for 3 sec RELEASE HOLD for 3 sec Release both buttons</p>	<p>To exit coding</p> <p>Then replace controls cover</p>
STEP SIX	
<p>Press to test</p>	

tip **HELPFUL TIP:** Refer to Appendix for Additional Transmitter coding functions



3.4.2 erasing programmed codes



STEP ONE	STEP TWO
<p>Switch power OFF</p>  <p>Switch power ON till Code LED flashes</p>	<p>Follow Section 3.4.1 to store new transmitter codes</p>

3.4.3 selecting the function to be coded





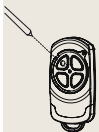

NOTE: Only the function of the existing transmitter button can be assigned to new transmitter. Please read instructions prior to proceeding - there is a time-out facility for security reasons.

- a) Using the existing transmitter, operate the Shutter with the transmitter button which has the function to be coded (e.g. Button 1 has been coded with the OSC function assigned).
- b) If the button's function activates the Shutter (PART, OSC, CLS, STP or OPN) wait for the Shutter to complete its cycle.

! tip Remotely coding works when you have a pre-coded remote control and are in range of the opener.

STEP ONE	STEP TWO
 <p>Take a pre-coded remote and press the button to duplicate</p>	 <p>Use a pen, HOLD for 2 sec the middle button through the coding hole</p>
STEP THREE	STEP FIVE
<p>Opener flashes & beeps</p>  <p>Take new remote</p> <p>HOLD for 3 sec RELEASE HOLD for 3 sec RELEASE</p>	<p>Opener stops flashing & beeping</p>  <p>Press to test</p>

3.4.4 installing a wall remote control

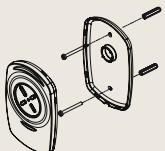
STEP ONE	STEP TWO
 <p>remove controls cover</p>	 <p>Press repeatedly till CODE LED is lit</p>
STEP THREE	
 <p>Press repeatedly</p>	 <p>till all three LED's are lit</p>
STEP FOUR	STEP FIVE
 <p>HOLD to enter coding</p>  <p>HOLD for 3 sec RELEASE HOLD for 3 sec Release both buttons</p>	 <p>To exit coding</p> <p>Then replace controls cover</p>
STEP SIX	
<p>Mount in view of door, away from children & at least 1.5m above floor.</p> 	

4.0 operation instructions

4.1 opener safety & security

4.1.1 the shutter CAN NOT be used when:

- a) There is a locking device installed.
- b) There is a power failure and batteries are not charged.

4.1.2 the shutter CAN be used when:

- a) There is an emergency, by disengaging the opener.
- b) There is a power failure, by the in built battery backup or by disengaging the opener.

4.1.3 to disengage the opener:

- a) It is recommended to do so with the shutter in the closed position.
- b) Pull down on the manual release cord, until you hear a click.

 **CAUTION!** When the opener is manually disengaged, the shutter is no longer locked. To lock the shutter manually, re-engage the opener after the shutter is closed.

- c) Move the shutter manually.

4.1.4 to re-engage the opener:

- a) Check the shutter has not been locked by a locking device.
- b) Pull down on the manual release cord, until you hear a click.
- c) The shutter will now operate from the opener.

 **WARNING!** Please test the manual release mechanism to ensure that the manual release is easy to operate. No more than 20kg of force should be required to disengage the shutter using the manual release cord. If excessive force is required reset the close limit position (Section 3.1.2 Resetting Shutter Limit Positions).

4.2 how to operate the opener

For maximum efficiency of your opener, your shutter must be in good operating condition. An annual service of your shutter by shutter professional is recommended.

4.2.1 to operate the opener:

- a) Press the programmed transmitter button until your shutter begins to move (usually 2 seconds). Make sure you can see the shutter when you use the transmitter (**Fig 7.1.1**).
- b) If you are in a vehicle you should aim the transmitter through your windscreen as shown.
- c) Check that the shutter is fully open or closed before you drive in or away.
- d) If you press the transmitter whilst the shutter is moving the shutter will stop. The next press of the transmitter will move the shutter in the opposite direction.

 **WARNING!** This operator has a grounding type plug and there are no user serviceable parts inside this operator.

 **CAUTION:** Activate the operator only when the shutter is in full view, free of obstructions and with the operator properly adjusted. No one should enter or leave while the shutter is in motion. Do not allow children to play near the shutter.

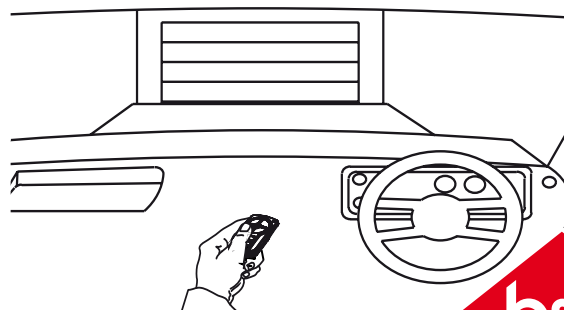

MANUAL RELEASE



WARNING! When operating the manual release (while the door is open) the door may fall rapidly due to weak or broken springs, or due to being improperly balanced. Do not disengage the operator to manual operation with children/persons or any objects including motor vehicles within the doorway.

IN THE EVENT THE DOOR BECOMES OBSTRUCTED DETACH DOOR FROM OPENER AS FOLLOWS:

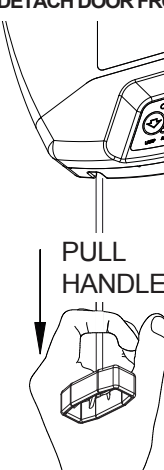

PULL HANDLE

1. TO DISENGAGE:
PULL HANDLE DOWN & RELEASE

2. TO RE-ENGAGE:
REPEAT ACTION

Fig: 4.1.1



4.2.2 user operating controls

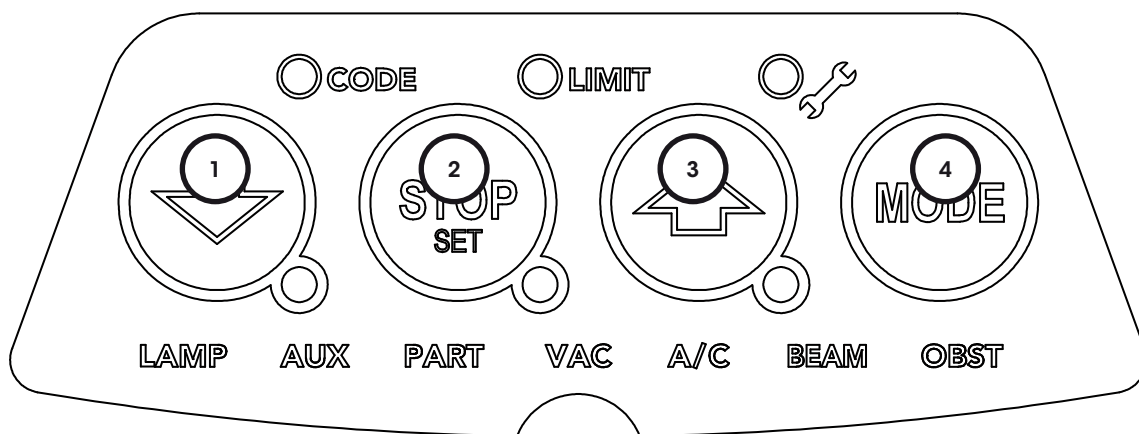

Button	Function
1. BLUE DOWN ARROW	Close Button
2. RED STOP/SET	Stop / Set Button
3. GREEN UP ARROW	Open Button
4. MODE	Mode Selection Button

4.3 shutter status indicators

Shutter Status Indicators	OPEN LED (green)	CLOSE LED (blue)	STOP (red)
Open	On		
Close		On	
Opening	Flashing		
Closing		Flashing	
Shutter travel stopped	Flashing	Flashing	Flashing
Shutter obstructed when opening	Flashing		On and shutter will stop
Shutter obstructed when closing		Flashing	Beeps while shutter is moving
Opener overloaded	Alternating flashes	Alternating flashes	
Mains power interrupted	Rapid flashes		

tip HELPFUL TIP: Refer to Appendix C for Additional LED Indicators



4.4 troubleshooting guide for opener

Symptom	Possible cause	Remedy
The opener does not work from the transmitter	<p>Garage shutter in poor condition e.g. springs may be broken</p> <p>The opener does not have power</p> <p>The battery in the transmitter is flat</p> <p>The opener has been put into "Vacation Mode"</p> <p>The transmitter button is not programmed to operate the shutter</p> <p>Shutter Code LED is flashing yet the opener is not working.</p>	<p>Check the shutter's operation (Section 2.7)</p> <p>Plug a device of similar voltage (e.g. a hairdryer) into the power point and check that it is OK</p> <p>Replace the battery (Section 5.2)</p> <p>Turn off "Vacation Mode" (Appendix E, Vacation Mode)</p> <p>See coding transmitter procedure (Section 3.4.1)</p> <p>Ensure the correct button on the transmitter is being pressed.</p>
The motor is running but the shutter remains stationary	The opener is disengaged	Re-engage the opener (Section 4)
The transmitter range varies or is restricted	<p>Variations are normal depending on conditions e.g. temperature or external interference</p> <p>The battery life is exhausted</p> <p>Position of the transmitter in the motor vehicle</p>	<p>See instructions for correct use of transmitter (Section 4.2.1)</p> <p>Refer to battery status (Section 5.2)</p> <p>Change the position (Section 4.2.1)</p>
The shutter reverses for no apparent reason	<p>This may occur occasionally from environmental conditions such as areas that are windy, dusty or have extreme temperature changes.</p> <p>If Safety Beams are installed they may be partially obstructed.</p>	<p>Put the shutter into manual (Section 4, take note of the CAUTION) and contact 1300 133 944.</p> <p>Ensure the beam path is not obstructed. If continues, contact your optional extras dealer.</p>
The shutter opens but will not close	Safety Beam (Optional Accessory) not operating correctly	Contact your optional extras dealer for support.
The Open (Green) LED and Close (Blue) LED are flashing alternatively	Opener is overloaded	Discontinue use and contact 1300 133 944 for support.
The Open (Green) LED continues to flash	Shutter obstructed when opening	Clear away any obstructions and test shutter opens correctly. (If shutter is damaged, contact a shutter professional).
The Close (Blue) LED continues to flash	<p>Shutter obstructed when closing</p> <p>Limits may be cleared</p>	<p>Clear away any obstructions and test shutter closes correctly. (If shutter is damaged, contact your dealer).</p> <p>Remove all power sources. Wait till all lights are out (10-15 secs), then reconnect power. If Blue LED is flashing, limits are not set. See Section 3.1 to set LIMITS.</p>



5.0 after installation care

5.1 service checklist

Preventative servicing of your shutter and opener, is just as important as servicing your car. Much like the engine of your car, your shutter is made up of numerous moving parts designed to lift and lower your door safely and efficiently.

Ongoing preventative servicing ensures that your shutter continues to function within factory specifications, greatly reduces the risk of failure and repair bills down the track and ensures you maintain your Warranty.



Run the Safety Testing procedures MONTHLY in Section 3.3 to ensure shutter is fit for use.



WARNING! Failure to maintain your shutter voids the warranty on your shutter opener.



DO NOT DO IT YOURSELF:
Door adjustments should only be carried out by experienced persons, as this function can be dangerous if not performed under strict safety procedures.

TECHNICIAN CHECKLIST

1. Lubrication of the critical moving parts including chain drive, tracks, wheels or cable drum.
2. Tightening of door mounting points along with door bolts, screws, cables and connectors.
3. Adjustment of spring tension to limit 'spring fatigue'.
4. Adjustment of opener travel limits and force margin to ensure the door opens and closes to specification.
5. Assessment and adjustment of safety components and accessories including safety beams, Auto-Lock and Safe Lock (if installed)
6. Assessment of the door alignment and the diagnosis of irregular operation remedies.
7. Record Cycle count at each service to establish next date of service (as per table)



	SERVICE 1 (12 months after installation or 3,000 cycles)		SERVICE 2 (3 years after installation)		SERVICE 3 (5 years after installation)	
DATE:						
BUSINESS NAME:						
TECHNICIAN NAME:						
PG3 COUNTERS	OPEN	CLOSE	OPEN	CLOSE	OPEN	CLOSE
STALLS						
OBSTRUCTIONS						
SENSOR FAULTS						
OVERLOADS / CUT-OUTS						
WARRANTY CYCLES						
FIRMWARE UPDATE AVAILABLE? IF 'YES' PLEASE UPDATE FIRMWARE	YES	NO	YES	NO	YES	NO
CURRENT FORCE MARGIN						
TECHNICAL SIGNATURE:						

	SERVICE 4 (7 years after installation)		SERVICE 5 (9 years after installation)	
DATE:				
BUSINESS NAME:				
TECHNICIAN NAME:				
PG3 COUNTERS	OPEN	CLOSE	OPEN	CLOSE
STALLS				
OBSTRUCTIONS				
SENSOR FAULTS				
OVERLOADS / CUT-OUTS				
WARRANTY CYCLES				
FIRMWARE UPDATE AVAILABLE? IF 'YES' PLEASE UPDATE FIRMWARE	YES	NO	YES	NO
CURRENT FORCE MARGIN				
TECHNICAL SIGNATURE:				



5.2 Battery Replacement

 **tip** Battery Type: 1 x CR2032.

STEP ONE	Light Status	Battery
 <p>Check Light Status Table </p> <p>HOLD</p>	Solid	OK
	Flashing	Replace
	No light	Replace

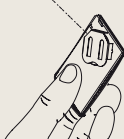
STEP TWO	STEP THREE
 <p>Use screwdriver to remove screws and open</p>	 <p>Use non-metallic object to push out.</p>

 **WARNING!** The battery is hazardous and must be kept out of reach of children. The battery can cause severe or fatal injuries within 2 hours or less if swallowed or placed inside any part of the body. If you suspect the battery has been swallowed or placed inside any part of the body, **SEEK IMMEDIATE** medical attention.

5.3 Battery Disposal

When batteries reach the end of their usual life in accordance with Australian Battery Recycling Initiative please follow the next simple steps for protecting the environment.

 **DO NOT** throw the batteries in municipal waste. This symbol of the crossed out wheeled bin indicates that the battery should not be placed in the municipal waste. Check your local regulations for appropriate disposal of the batteries.

Recycling all batteries will have other environmental and social benefits:

- Some batteries are less toxic but hazardous for other reasons. Lithium batteries can explode or catch fire in landfill, while button cells are dangerous if swallowed by children. Recycling offers a safe and environmentally responsible solution for end of life batteries.
- Battery recycling recovers non-renewable materials such as lead, cadmium, steel, zinc, manganese, cobalt, silver, plastics and rare earth elements.
- Removal of batteries and other hazardous household products from household waste facilitates the recovery of organic materials through alternative waste technologies such as composting. Batteries and heavy metals are known contaminants in compost.
- The community supports recycling because it reduces waste to landfill and achieves environmental benefits.

 **WARNING!** Prior to disposal, recycling, or collection, all battery terminals must be securely insulated with a non conductive material to prevent any two batteries from short circuiting and generating heat during storage or transport. Battery terminals may be insulated with electrical tape; or batteries may be individually packaged in a non conductive material (e.g. plastic bag or original packaging).



5.4 care for your ESY Shutter™

Your B&D ESY Shutter has been manufactured from galvanised or powder coated steel, which is one of the best paint films commercially available today. However, all exposed surfaces require some attention to guard against the premature onset of corrosion and any other harmful atmospheric effects. In our atmosphere there are harmful deposits that gather on the shutter surface and if not removed regularly, will seriously affect the appearance and life of the shutter.

Note: Be aware of electric shock.

Washing of the shutter with clean water and a cloth is recommended – particular care should be taken to clean areas of the shutter not normally washed by rain.

lock

Your lock does not require special maintenance, however, if the mechanism becomes stiff, the application of a suitable lubricant is advised.

regular maintenance required

B&D recommends that you check the operation of your ESY Shutter at least every six months (more regularly in extreme environments or frequent use). The effort required to manually open and to manually close the shutter should be about the same (if shutter has an automatic opener, put into manual mode before testing shutter).

Note: The shutter guide grease should be cleaned out and replaced least annually or more frequently in extreme conditions.

If the shutter is difficult to operate in either direction (up or down) then check that the inside surfaces of the guides are clean and free of obstructions.

If the shutter is still difficult to operate, then your shutter will need a service to adjust the spring tension and possibly other operational parts of the shutter.

This service should only be carried out by an experienced shutter technician, using the correct tools.

If you have an automatic opener fitted to your shutter, it is particularly important that you ensure the optimum operation of the shutter, otherwise you may reduce the effective life of the opener.

To keep your shutter running well, it is recommended that your shutter be serviced, by an experienced shutter technician, every 12 months (more regularly in extreme environments or frequent use), or earlier if required.

spring tension

It is natural for springs to lose tension over time. When spring tension is adjusted or when your shutter is first installed it is usual to apply a little more tension than is required for balanced operation, to allow for the normal "settling in" of the springs.

WARNING: The springs on the shutter are under extreme tension. On NO account should they be adjusted by an inexperienced person. B&D recommends regular servicing and safety checks be carried out at least annually, more frequently in extreme conditions or in high use environments.

warranty

B&D ESY Shutter and GDO-12RAS Hiro opener is covered by a 2 year or 10,000 cycle warranty for complete shutter, opener and parts, surface (excludes salt corrosion). Opener warranty is conditional on proper servicing as listed in 5.1 Service Checklist.

Warranty conditional on proper care as recommended above. Full details of the warranty are available from www.bnd.com.au



6.0 appendix

A - adjustment mode parameters

STEP ONE

Remove controls cover

Press repeatedly till Spanner LED is lit One of the word LED's will light up

STEP TWO

Press to move to particular parameter LED Press to enter parameter

STEP THREE

will flash to indicate parameter value in table below

STEP FOUR

Use either button to scroll through

If no beep is heard, max or min setting is reached.

LED Indicators	Parameter	OPEN	OPEN & STOP	STOP	CLOSE & STOP	CLOSE
LAMP LED	Light Time	180s	120s	60s	30s	0s
AUX LED	Aux Time / Mode	Toggle	60s	30s	1s	Mimic Light
A/C LED	A/C Function	90s	60s	30s	15s	OFF
A/C & BEAM LED'S	PE A/C Function	60s	30s	15s	5s	OFF
OBST LED	Margin Setting	20 units	15 units	12 units	9 units	7 units
OPEN / STOP / CLOSE LED'S	PG3 custom setting	When all three lights are illuminated a custom setting is in place. Parameters can be still adjusted to those listed above.				

STEP FIVE

Press to save Press to leave unchanged Press to exit

Operating MODE is entered after 5 secs, unless a new adjustment is started or saved.

Auxiliary Output



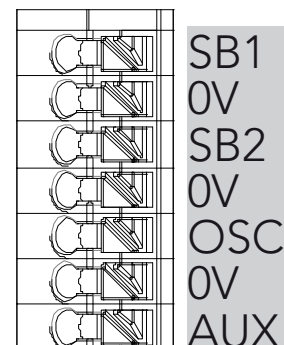

The auxiliary output can be used to control alarm or another garage shutter opener. A valid transmission from the pre-coded transmitter will cause the auxiliary output to pulse for approximately 1 (one) second. The maximum DC voltage must not exceed 35 volts DC. Maximum current must not exceed 80 ma.



B - setting the PET Mode position

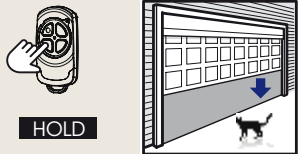

When activated, PET mode drives the door to a preset position from the close position, therefore allowing a pet or parcel to go under the door.

STEP ONE	STEP TWO
 <p>HOLD</p> <p>Close to desired position</p>	<p>Remove controls cover</p>  <p>Press repeatedly till LIMIT LED is lit</p>
STEP FOUR	STEP FIVE
 <p>Press repeatedly</p> <p>till PART LED lit</p>	 <p>HOLD for 2 secs</p> <p>Release</p> <p>Proceed to Appendix E to code a remote button to PART Mode</p>

C - LED status

The below table displays the status of the opener when LEDs are activated.

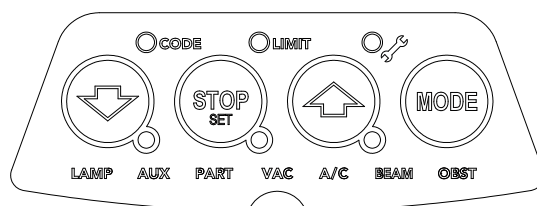

LED Indicators		Status
CODE LED		Flickers with transmitter activity or indicating transmitter may not be coded to the opener.
LIMIT LED		Indicates the opener is in Limit Set Mode
SPANNER LED		Indicates the opener is in Adjustment Mode
CLOSE / STOP / OPEN LED'S		Indicate the shutter status currently in use (except during power failure, auto-close and part open)
LAMP LED		Only illuminates during the Adjustment Mode to change the light time parameter
AUX LED		Indicates the AUX output is activated, once a transmitter has been coded to the AUX function.
PART LED		Indicates the shutter is in one of the part open positions.
VAC LED		Indicates the Vacation Mode is active
A/C LED	On STEADY	means the auto-close timer was paused due to the beam being blocked.
	FLASHES	to indicate the auto-close timer is running
BEAM LED	On STEADY	when a beam is blocked.
	FLASHES	when there is a P.E Fault
OBST LED	On STEADY	Obstruction was detected. If shutter open then obstruction was while closing and vice versa.
	FLASHES	Stall / Overload detected. If shutter open then stall / overload while closing and vice versa.
SPANNER LED	On STEADY	Indicates the service is due. Beeps three times at start of a drive cycle
	MAIN LIGHT FLASHES	Two flashes indicates that the battery is faulty. Five Flashes indicates that periodic maintenance is due after 3000 drive cycles.
	FLASHES	Indicates a fault. The details is indicated on the other LEDs.
	+ OBST LED + OPEN LED + CLOSE LED + LIMIT LED + CODE LED + OPEN & CLOSE LEDs	Indicates current sensor fault Indicates failed to profile open travel - during limit setting only indicated failed to profile close travel - during limit setting only indicates position wrap fault / position sensor fault indicates memory fault indicates direction fault

D - setting limits via transmitter

The GDO-12RAS Hiro has the ability to set travel limits using a transmitter, allowing free movement around the garage to better assess the desired limit positions. In order to use a transmitter, it must first have at least one of its buttons coded to the shutter controller. The function assigned to the transmitter's buttons is of no concern here as the buttons are temporally assigned to OPEN, SET, CHANGE DIRECTION and CLOSE (Fig. D.1).

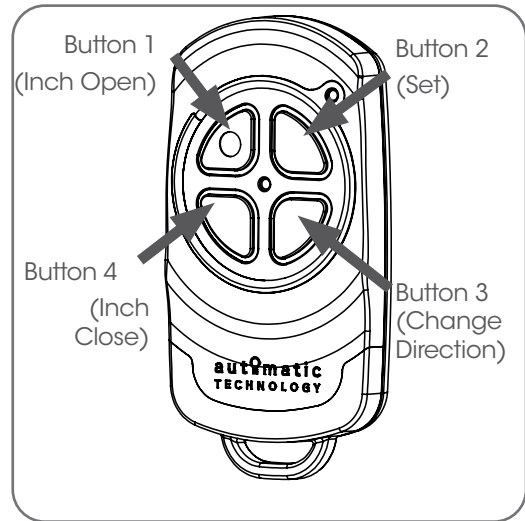









Fig: D.1

D.1 code a transmitter for limit setting



tip The SPEED setting on the opener CAN NOT be adjusted when setting limits via the transmitter. Follow section 12.1 to set limits and adjust speed.

STEP ONE	STEP TWO
   <p>Switch power on. BLUE LED will flash</p>	  <p>Press repeatedly till CODE LED is lit</p>

STEP THREE	
 <p>OR</p>  <p>Press repeatedly</p>	   <p>till all three LED's are lit</p>

STEP FOUR	STEP FIVE
  <p>HOLD to enter coding</p> <p>HOLD for 3 sec RELEASE HOLD for 3 sec Release both buttons</p>	 <p>To exit coding</p> <p>Then replace controls cover</p>



CLOSE LIMIT POSITION

STEP ONE	STEP TWO
  <p>HOLD to Close</p> <p>Button 4 is factory coded to CLOSE function.</p>	 <p>When door near close, single presses inch door</p> <p>CLOSE limit should be when rubber strip touches the ground</p>

WARNING! In setting the close limit position, do not force the door into the floor with excessive force, as this can interfere with the ease of operation of the manual release mechanism.

STEP THREE	
<p>If door overshoots</p>  <p>Press to Open</p>	<p>Press to set</p>   <p>Button 2 is factory coded to SET function</p>

OPEN LIMIT POSITION









STEP ONE	STEP TWO
  <p>HOLD to Open</p> <p>Button 1 is factory coded to OPEN function.</p>	 <p>When door near open, single presses inch door</p> <p>OPEN limit should be the height of the garage opening</p>

WARNING! The door will automatically close. open and close again after the next step. Ensure that nothing is in the door's path.









STEP THREE		
<p>If door overshoots</p>  <p>Press to Close</p>	 <p>Press to Open position</p>	 <p>Press to set</p>

E - additional transmitter functions









E.1 transmitter button to the courtesy light

STEP ONE		STEP TWO	
 remove controls cover		 Press repeatedly till CODE LED is lit	
STEP THREE			
 OR 		LAMP	
Press repeatedly		till LAMP LED lit	
STEP FOUR		STEP FIVE	
 →  HOLD to enter coding		 → To exit coding Then replace controls cover	
HOLD for 3 sec RELEASE HOLD for 3 sec Release both buttons		STEP SIX	
		 Press to test	







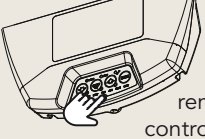

E.2 transmitter button to enable AUX output

STEP ONE		STEP TWO	
 remove controls cover		 Press repeatedly till CODE LED is lit	
STEP THREE			
 OR 		AUX	
Press repeatedly		till AUX LED lit	
STEP FOUR		STEP FIVE	
 →  HOLD to enter coding		 → To exit coding Then replace controls cover	
HOLD for 3 sec RELEASE HOLD for 3 sec Release both buttons		STEP SIX	
		 Press to test	

E.3 transmitter button to operate PART Mode

STEP ONE		STEP TWO	
 remove controls cover		 Press repeatedly till CODE LED is lit	
STEP THREE			
 OR 		PART	
Press repeatedly		till PART LED lit	
STEP FOUR		STEP FIVE	
 →  HOLD to enter coding		 → To exit coding Then replace controls cover	
HOLD for 3 sec RELEASE HOLD for 3 sec Release both buttons		STEP SIX	
		 Press to test	

E.4 transmitter button to activate vacation mode

STEP ONE		STEP TWO	
 remove controls cover		 Press repeatedly till CODE LED is lit	
STEP THREE			
 OR 		VAC	
Press repeatedly		till VAC LED lit	
STEP FOUR		STEP FIVE	
 →  HOLD to enter coding		 → To exit coding Then replace controls cover	
HOLD for 3 sec RELEASE HOLD for 3 sec Release both buttons		STEP SIX	
		Turn on → Turn off  →  HOLD for 4 sec RELEASE Press, then try another remote	



F - optional extended battery backup

a) To mount battery backup pack ① onto the wall, use the battery pack as template to mark where to drill holes as per **Fig F.1**. Pre-drill holes and affix to wall with appropriate screws.

! WARNING! After Step (b) the opener may become active (even when power is off). This is a result of a residual charge in the batteries.

b) Connect battery harness ② plug through opening to control board on the GDO-12 RAS as shown in **Fig F.1**.

! WARNING! Secure the manual release handle and string with the accessory supplied, so that the string is away from moving parts.

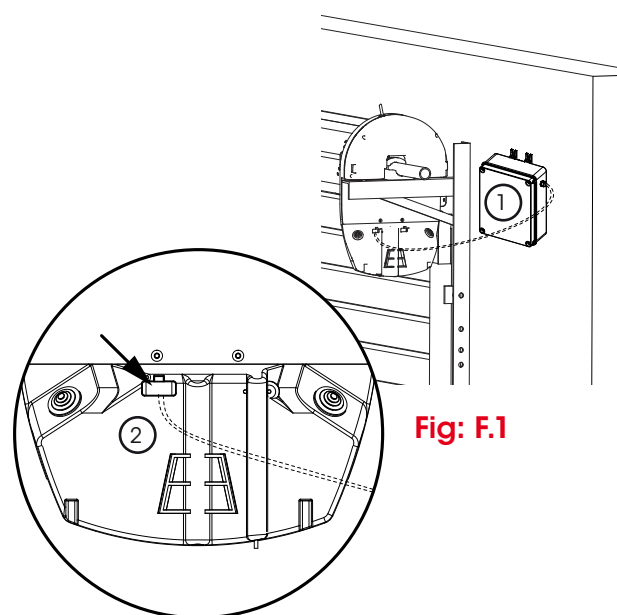

Fig: F.1

b&d doors office locations

Head Office	6-8 Fiveways Blvd, Keysborough 3073	Phone (03) 9791 2000
New South Wales	34 Marigold St, Revesby 2212	Phone (02) 9722 5555
Queensland	17 Oasis Court, Clontarf 4019	Phone (07) 3883 0200
Victoria	147-153 Canterbury Rd, Kilsyth 3137	Phone (03) 9237 7766
South Australia	23 Frederick Rd, Royal Park 5014	Phone (08) 8440 4747
Western Australia	96 Mulgool Rd, Malaga 6090	Phone (08) 9247 8777
International/Export	34 Marigold St, Revesby 2212	Phone +61 (0)2 9722 5555

your representative is

Prefixed trademarks are the property of B&D Australia Pty Ltd. B&D Doors & Openers is a division of B&D Australia Pty Ltd. ABN 25 010 473 971. © 2018 B&D Australia Pty Ltd.

www.bnd.com.au

