

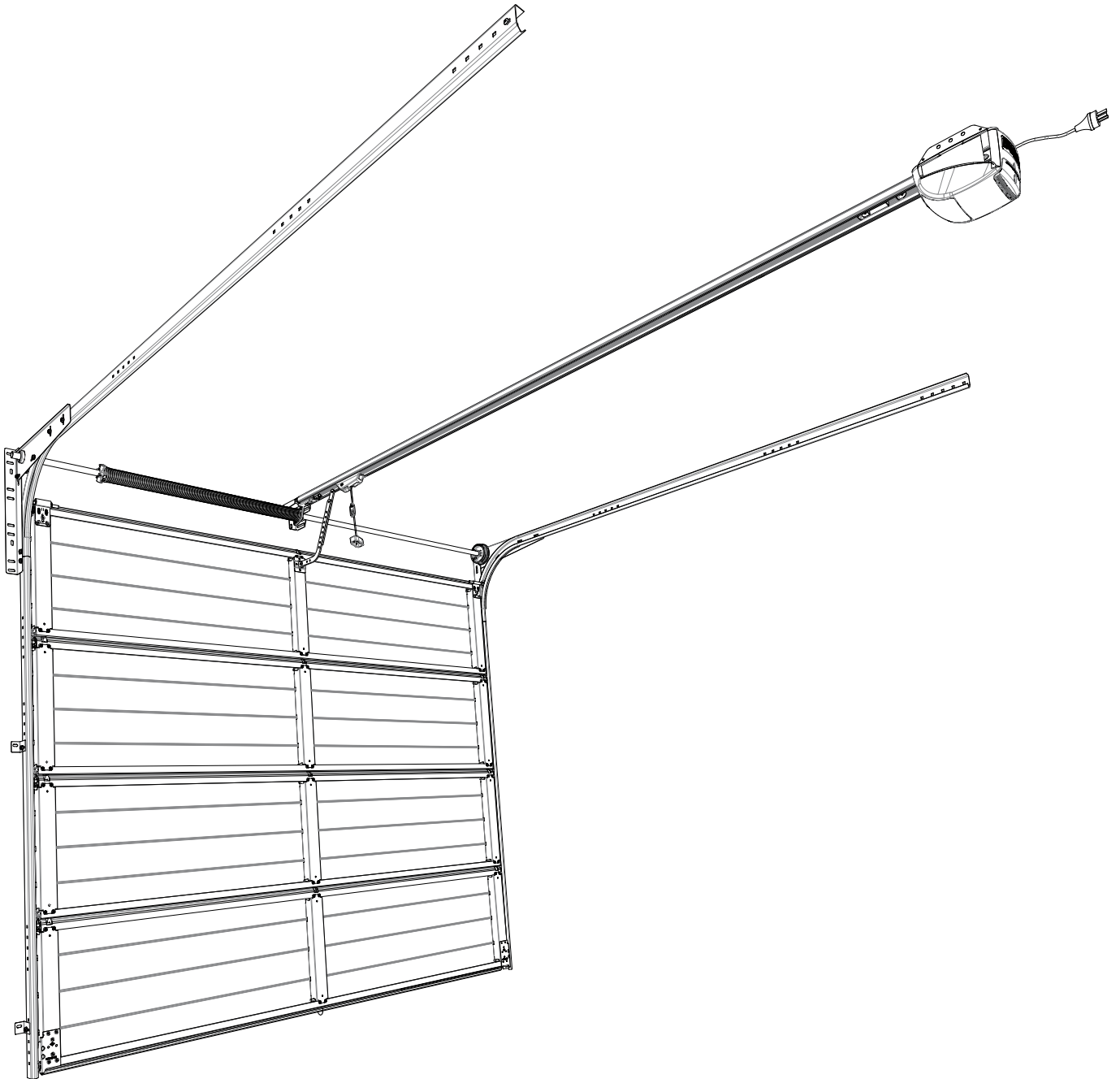

**b&d**

# Panelift® B

Model: PFH installation instructions



These instructions are intended for professional garage door installers. All references are taken from inside looking out.

DOC# 165002\_05  
PART NO# MS0153  
RELEASED: 19/09/2023

[www.bnd.com.au](http://www.bnd.com.au)



**b&d**

## contents

<b>1.0 before you begin</b>	<b>3</b>
1.1 installation safety warnings	3
1.2 fastener recommendations for fitting Panelift® B	4
1.3 parts checklist	5
1.4 requirements before installation	6
1.4.1 measurements	6
1.4.2 initial calculations	6
1.5 tools	6
<b>2.0 assembly</b>	<b>7</b>
2.1 vertical tracks	7
2.2 door panels	7
<b>3.0 installation</b>	<b>9</b>
3.1 installing vertical tracks	9
3.2 adding panels	10
3.3 fitting reinforcing	11
3.4 installing horizontal tracks	12
3.5 standard spring counterbalance system	13
3.6 install torsion bar	14
3.7 adding tension to spring	15
3.8 final checks	16
<b>4.0 troubleshooting</b>	<b>17</b>
<b>5.0 appendix</b>	<b>19</b>
5.1 hinged tapers	19
5.2 after installation care	20

# 1.0 before you begin

## 1.1 installation safety warnings

This B&D Door is designed and tested to provide security, attractive appearance and smooth , low effort operation provided it is installed and operated in strict accordance with the following safety warnings. Failure to comply with the following instructions may result in death, serious personal injury or property damage.

**NOTE:** No guarantee will be given or responsibility accepted by the manufacturers if the door is not installed as instructed.



### WARNING!

Crush injury from unsecured door

Tension Springs

- Place a 2 metre exclusion zone around area under the garage opening while installing door. If sufficient area is not available DO NOT install door.
- Follow the installation instructions.
- Ensure correctly fitting winding bar is used.
- Ensure the correct length winding bar is utilised.
- Ensure winding bar is placed appropriately in the torsion socket plug.
- Ensure correct bolts are tightened or loosened (or clamp pliers) to ensure there is no release or controlled release of energy from the spring either through the torsion bar or the winding bar.
- Keep hands clear of the torsion plug at all times.
- Keep head clear of the tensioning bar at all times.



### ELECTROCUTION!

- Check risk assessment for any highlighted electrical power concerns.
- Ensure power source is isolated prior to commencement of job.
- Turn off electricity to site when necessary.
- Ensure you check the substrate for electrical wiring prior to penetration.
- Wear rubber soled footwear.



### LACERATION:

- Wear appropriate PPE (Dyneema cut off gloves) and keep hands well clear of pinch points.
- Follow instructions explicitly, particularly for the installation of some parts of the panel doors, as the unrolled cut out edges presents a very sharp edge.



### CAUTION:

Muscular strain

Fall from ladder

Hand Tools

Entanglement

- Practice correct lifting techniques when required.
- Use mechanical aids such as lifting devices, forklift and cranes where possible.
- Avoid twisting.
- Ensure ladder is the correct type for job.
- Ensure ladder is on flat firm ground that will take the weight without the legs sinking.
- Ensure user has 3 points of contact while on ladder.
- Wear appropriate PPE and utilise operators manual of all tools.
- Use appropriate noise/hearing protection in the form of ear plugs or ear muffs.
- Ensure appropriate fire protection available and housekeeping to ensure that flammable liquids or materials are removed from the area of work.
- Keep hands and loose clothing clear of moving door and guides at all times.



### TWO PERSON LIFT:

- Depending on the size of the door, this product may requires a two person lift. Use proper techniques and equipment to lift the door from the trailer and into position.

## 1.2 fastener recommendations for fitting Panelift® B

substrate type	fastener required	washer required	plug required	drilled hole ø (mm)	min hole depth (mm)		B&D fastner pack	
					Unlined	Plaster Lined	100pk	500pk
solid brick (>10 MPa)	screw, coach 5/16 - 9tpi x 50	washer flat M8	plug, nylon 5/16 x 50	10	60	90	FK0011	FK0012
three hole brick (> 30 MPa)	screw anka M8 x 75 flange hex head	washer 3/8"	n/a	8	75	75	FK0024	FK0023 (50PK)
ten hole brick (>15 MPa)	screw anka M8 x 75 flange hex head	washer 3/8"	n/a	8	75	75	FK0024	FK0023 (50PK)
concrete block (> 8 MPa)	screw anka M8 x 75 flange hex head	washer 3/8"	n/a	8	75	75	FK0024	FK0023 (50PK)
concrete (> 15 MPa)	screw, coach 5/16 - 9tpi x 80	washer flat M8	plug, nylon 5/16 x 80	10	60	90	FK0013	FK0014
timber	screw, coach 5/16 - 9tpi x 50	washer flat M8	n/a	5	60	90	FK0011	FK0012
steel section (0.9-2mm thick)	screw tek 14g - 20tpi x 25 flange hex head ZP	washer flat M8	n/a	n/a	n/a	n/a	FK0019	FK0020

### important notes

1. For installation to substrate materials not covered in the above chart, the installer should seek expert advice
2. Substitute fasteners are not recommend unless approved.
3. The above chart specifies the fasteners for new substrate materials only. Seek specialist advice regarding pre-existing substrate materials.
4. It is important that correct washer and plug is used and the correct pilot hole drilled where specified.



### WARNING!

The installer must select and use fasteners appropriate to the material into which they are being fixed.

## 1.3 parts checklist

### 1.3.1 pack contents

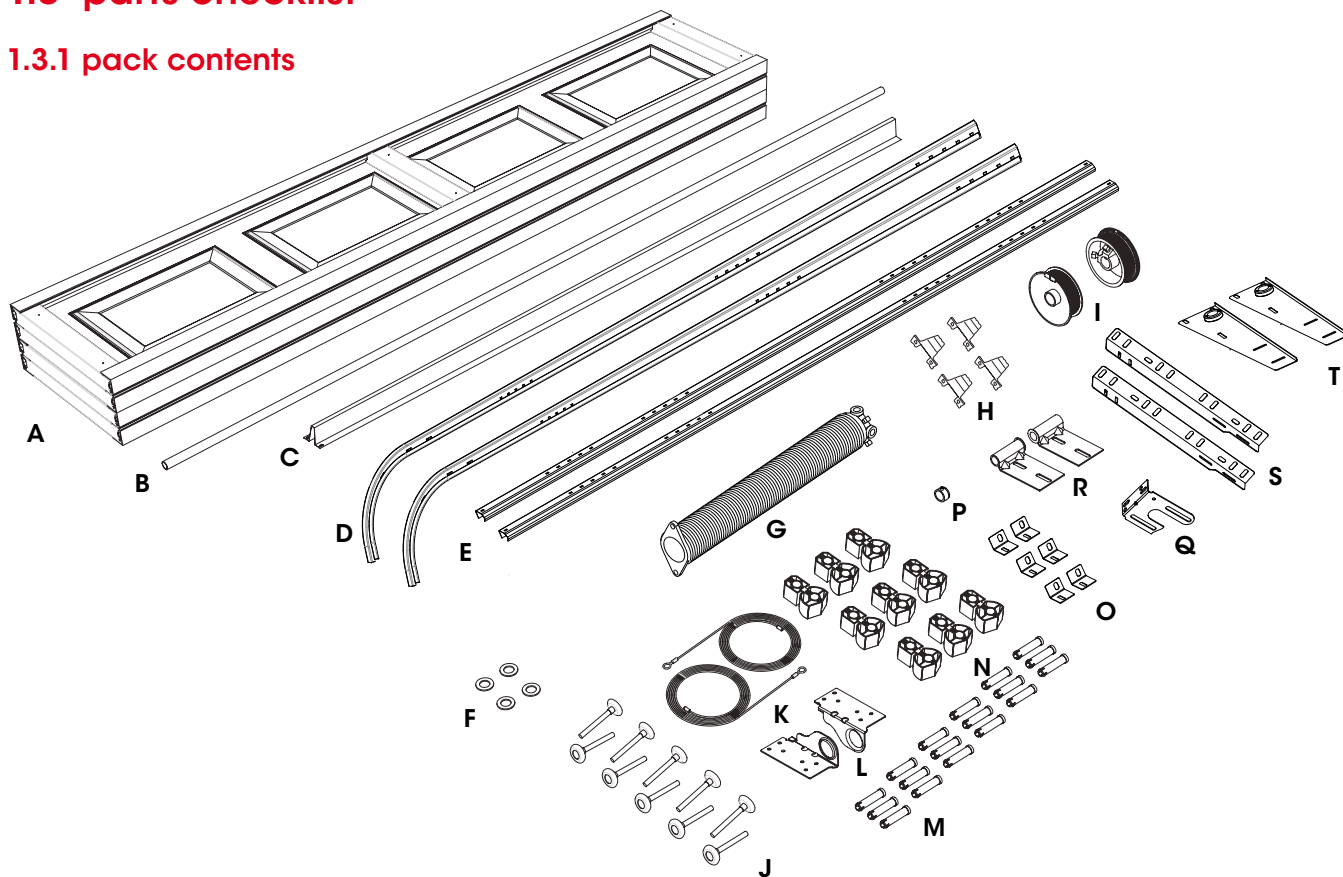

PANELIFT SECTIONAL DOOR		
ITEM	DESCRIPTION	QTY
A	DOOR PANELS PACKAGE	1
B	TORSION BAR (TUBE OR SOLID)	1
C	PANEL REINFORCING	1+
D	HORIZONTAL TRACKS	2
E	VERTICAL STRAIGHT TRACKS	2
F	WASHERS	4
G	TENSION SPRING	1-4
H	REINFORCING END CAPS	2+
I	CABLE DRUMS	2
J	WHEEL AXLES 48mm	10+
	WHEEL AXLES 46mm	2
K	LIFTING CABLE	2
L	BOTTOM HANGERS	2
M	HINGE PINS	18+
N	HINGE LINKS	9+
O	SMALL ANGLE JAMB BRACKETS	6+
P	SHAFT COLLAR	1
Q	SPRING ANCHOR BRACKET	1
R	TOP HANGER	2+
S	TOP ANGLE BRACKET	2
T	TOP BEARING BRACKET	2

## 1.4 requirements before installation

**mounting** - The door is designed to be mounted behind the opening.

**obstructions** - Ensure that the surface where the door will be fitted is flush and smooth, and the area behind the opening is free from any protrusions.

**structural suitability** - Ensure the opening is strong enough to support the door. If unsure, consult a builder.

**level and plumb** - The door must be installed in an absolutely level position, if opening is not level and square, appearance and/or sideroom requirements will be affected. The floor should be level or recessed across the opening to avoid gaps.

### 1.4.1 measurements

**opening width** - As the door overlaps each side by 30mm or more, the door should be 60mm wider than the opening. A wider door can be fitted as long as additional sideroom and fixing is available. (Fig 1.4.1)

**opening height** - The door will fit any opening height up to the marked door size.

**sideroom** - A minimum of 120mm (140mm for double wheels and axles) of sideroom is required over and above door width and should extend above the head to allow for bracket fixing.

**headroom** - a minimum of 300mm (320mm with combo brackets) of headroom is required.

**backroom** - as the door extends into the garage when opening a minimum of the door height + 350mm for tracks is required.

**level datum** - use a water or lazer level to mark a datum line on both sides of the lintel as shown. Fig 1.4.1.

**vertical track length** - the track length is calculated using the below equation see 1.4.2.

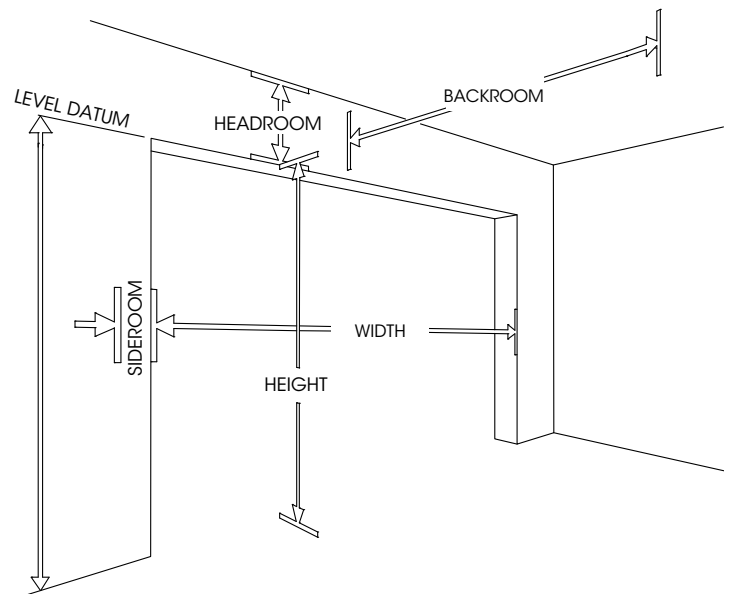

Fig: 1.4.1

### 1.4.2 initial calculations

- Open the package of door panels and locate the label on the end of the door panel.
- The label lists the Sales No: XXXXXX, then underneath DH: X,XXXmm (door height).
- Calculate the vertical track length:

**tip**  $\text{door height} - \text{headroom} = \text{vertical track length}$

standard HR 220mm  
restricted HR 345mm

- Calculate the horizontal track brace position:

**tip**  $\text{door height} \times 0.66 = \text{horizontal track brace position}$

## 1.5 tools

It is recommended that this door is installed by a professional door installer using a professional and specialised tool kit.

## 2.0 assembly

### 2.1 vertical tracks

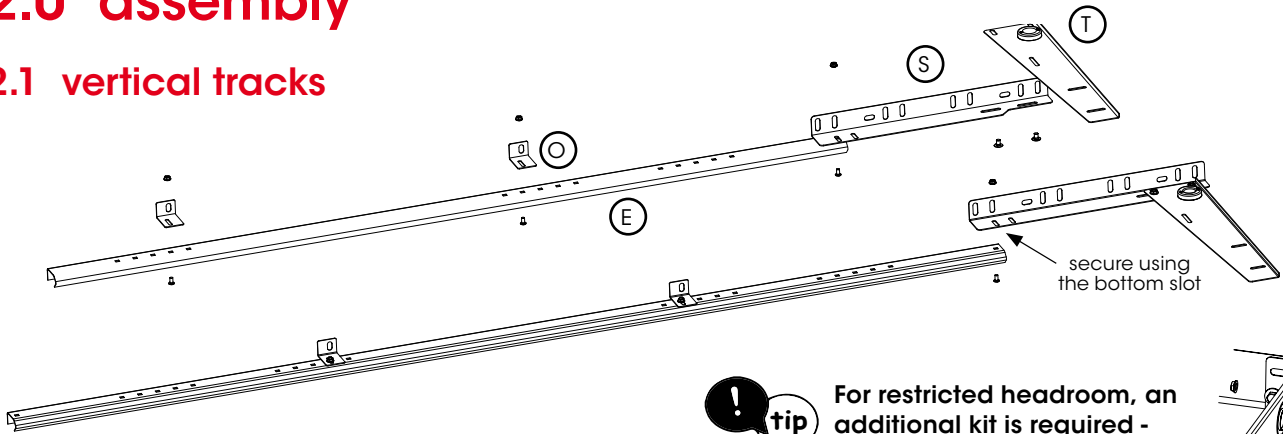

**Fig: 2.1.1**

- Before cutting the vertical tracks, measure from the horizontal datum line to the floor on each side to determine if floor is level.
- Add any difference to the vertical track cut height which calculated length is listed in section 1.4.2. Cut the Vertical Straight tracks **E**.
- Attach the top bearing bracket **T** to top angle bracket **S** using 4 x 5/16 bolts and nuts.
- Affix the top angle bracket **S** and small angle jamb brackets **O** to the vertical tracks using 6 x 1/4 bolts and nuts, noting the distance required from the wall to the track and the bottom jamb bracket should be approximately 150mm from the floor and the second half way between it and the top of the track.



**tip**

For restricted headroom, an additional kit is required - Part No: SDO368.

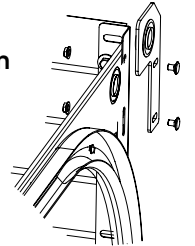

**NOTE:** The small angle jamb brackets and the top angle bracket, provide adjustable slots to move the track out from the wall. Take note of Fig 3.1.2 for measurements.

**NOTE:** The fixing flange can be placed in either the standard or limited sideroom position. For the restricted headroom quick closer system, the additional "L" shaped bearing brackets are fitted in addition to the standard bearing brackets.

brackets turned in for limited sideroom

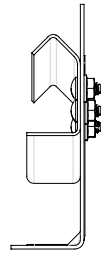

### 2.2 door panels

**NOTE:** Refer to 5.1 appendix if installing a taper.

- Open up the pack of door panels, making sure the bottom panel (weather strip seal on the bottom of the panel and bottom hinge hole) is on top of the pack. Start with the bottom panel.
- Insert each lifting cable **K**, through the holes of the left and right bottom hangers **L** Fig 2.2.1.

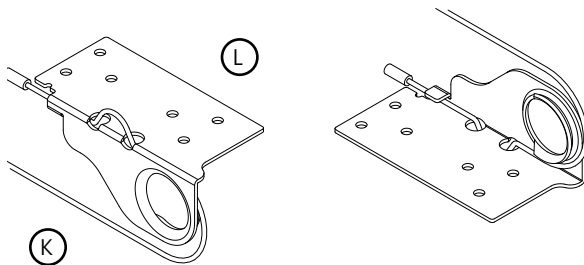

**Fig: 2.2.1**



**CAUTION:** DO NOT hold cable in place by squeezing the bracket around it as this will cause the cable to fracture and break.



**tip** Should you need to temporarily hold the cable in place during installation, before spring tension is applied, only secure with stick tape.

- Remove existing screws in the two bottom corners of the bottom panel near the weather strip and discard.

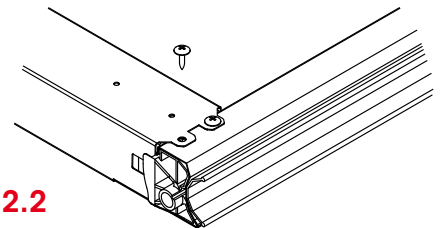

**Fig: 2.2.2**

- Attach the left and right bottom hangers to the lower end of the door using 6 x TEK screws in each and insert 2 x 46mm wheel axles **J** into bottom of panel, Fig 2.2.3.

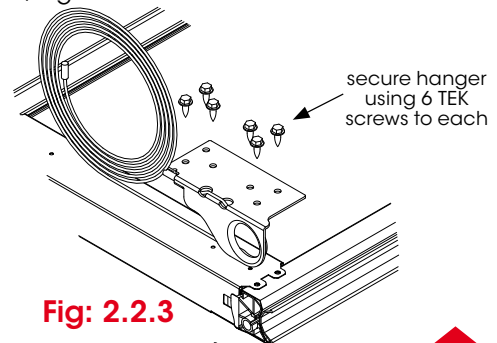

**Fig: 2.2.3**

**J** 46mm wheel axles

- e) Insert the hinge link (N) into the recesses of the top of the panel and fix into place using the white hinge pins (M). Fig 2.2.4.

**tip** There is a link for every point where there is a stile.

**CAUTION:** Ensure the axles are lightly lubricated with general purpose lithium grease before inserting.

- f) Insert 2 x the appropriate wheel axle (J) (standard, extended or smooth track) into the top of the panel.  
g) Repeat the process for fitting links, pins and wheel axles to the top of each middle panel.

NOTE: The top panel can be easily identified by always having a centre stile for use with an opener and no hinge link cut outs in the curved top edge.

**CAUTION:** Ensure the axles are lightly lubricated with general purpose lithium grease before inserting.

- h) Insert the appropriate wheel axle (J) (standard, extended or smooth track) into the top hanger (R) Fig 2.2.5.  
i) Attach the top hangers to the top corners of the panel, using the vertical slots only. Fig 2.2.6.

NOTE: The additional two fixings will be fitted to the left and right side after the panel is lowered into the tracks and adjusted to vertical.

**WARNING!** Ensure all tek screws indicated are fitted after adjusting. Fig 2.2.7.

**tip** Refer to BAL-Maze instructions to fit optional panel seals if purchased.

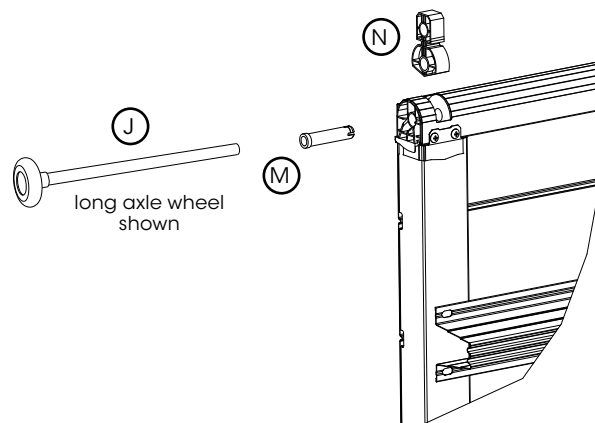

Fig: 2.2.4

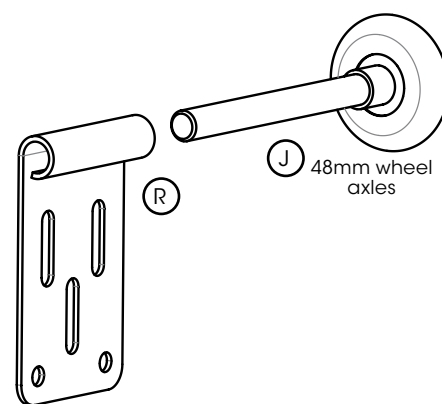

Fig: 2.2.5

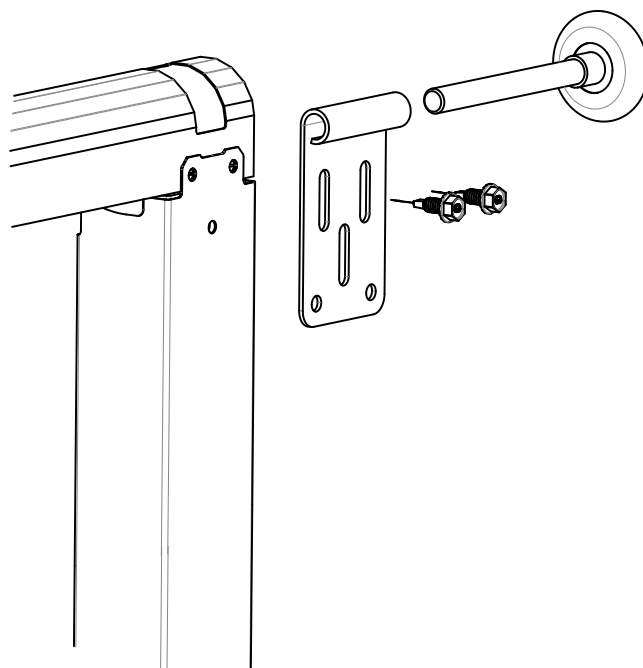

Fig: 2.2.6

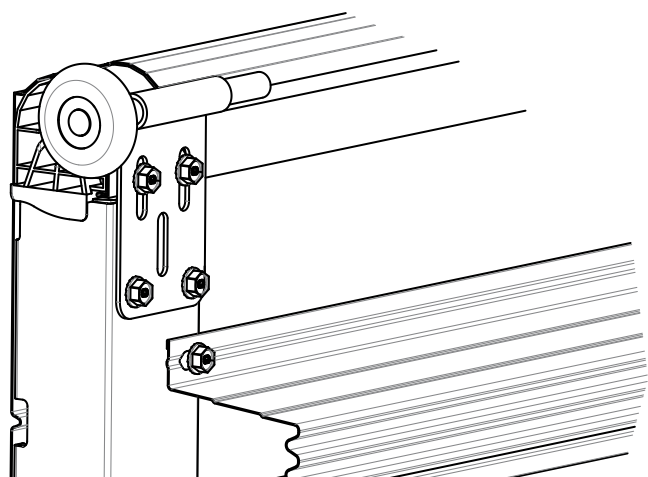

Fig: 2.2.7

## 3.0 installation

### 3.1 installing vertical tracks

**CAUTION:** If jamb seals are being fitted they should be cut 100mm taller than the door height and fitted prior to fitting the vertical tracks.

- Set the vertical tracks parallel on both sides of the door. Use the level/datum marks to ensure the tracks are level with each other or the door will not function correctly. Fig 3.1.1
- Ensure to follow the measurements as shown in Fig 3.1.2 to set out the placement of the track and brackets.

**tip** Refer to BAL-Maze instructions for measurements on track placement.

- Once satisfied temporarily fix in position with at least **three (3) fixings** to the top bracket and one to each of the lower track brackets. These will hold the tracks in position and allow for minor adjustments.

**WARNING!** All fixings with washers must be fitted after the door is fully adjusted and operating satisfactorily.

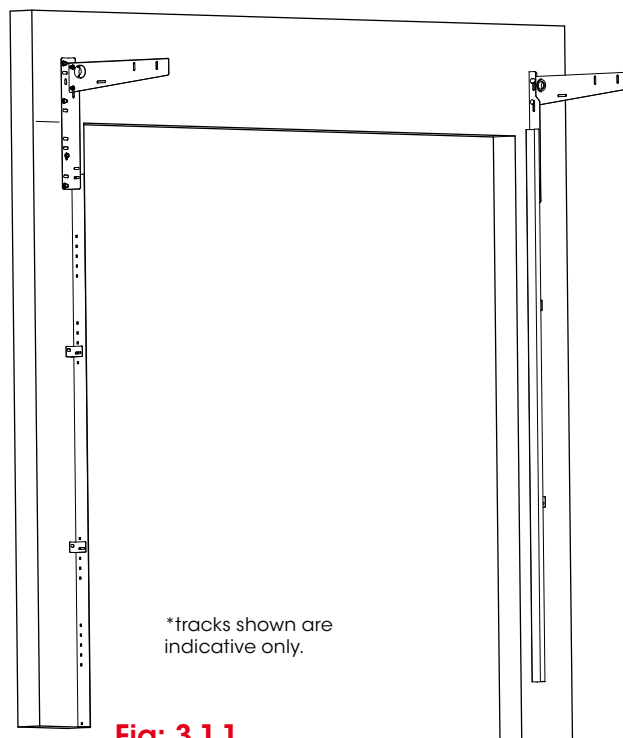

Fig: 3.1.1

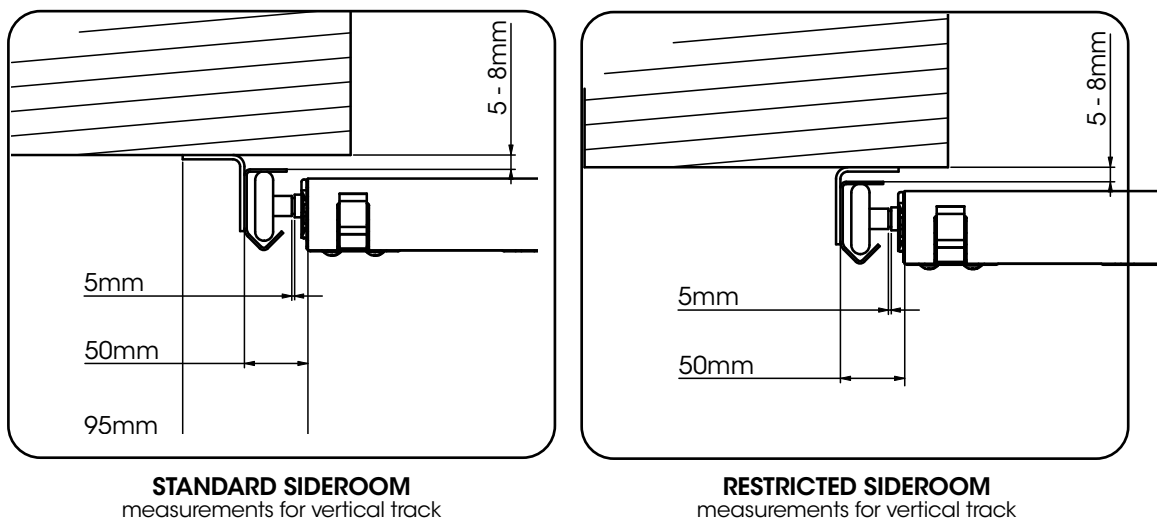

Fig: 3.1.2

## 3.2 adding panels



**TWO PERSON LIFT:** depending on the size of the door, this process may require two persons to lift into place.

- Carefully lower the wheels of the bottom panel into the tracks and lower so the panel is sitting level in the door opening. Fig 3.2.1.
- Check that the wheels are sitting in the "V" groove of the vertical track on each side and there is sufficient clearance between the panel and the track as per Fig 3.1.2.
- Insert the next panel into the tracks and rest on top of the bottom panel. Fig 3.2.2.

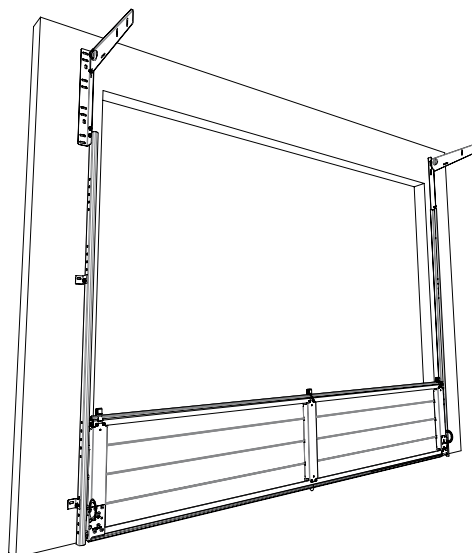

Fig: 3.2.1

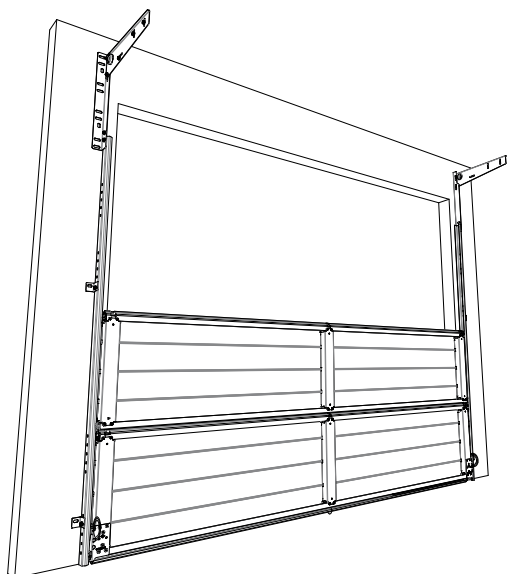

Fig: 3.2.2

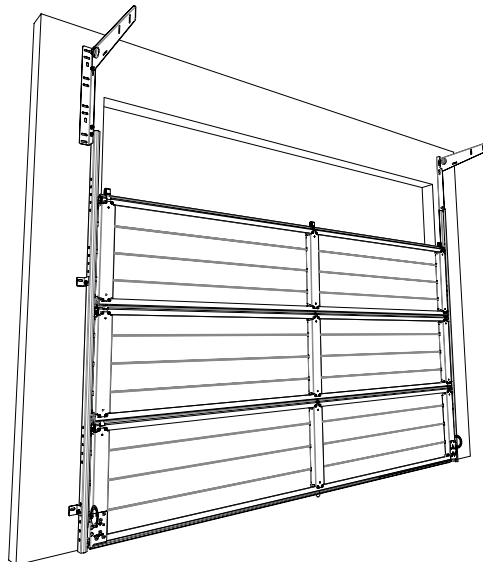

Fig: 3.2.3



**WARNING!** Use caution when adjusting and securing hinge links between panels as pinching may occur.

- Starting in the centre, lift the panel enough to ensure each link is in its respective recess and white pins are fitted to hold links in place before operating the door.
- Repeat this procedure for all other panels with the exception of the top panel which has externally mounted adjustable metal hangers.
- When finally adjusted the additional fixings must be added. Fig 3.2.4.



**CAUTION:** Ensure the warning label is placed on the door in a clearly visible position.

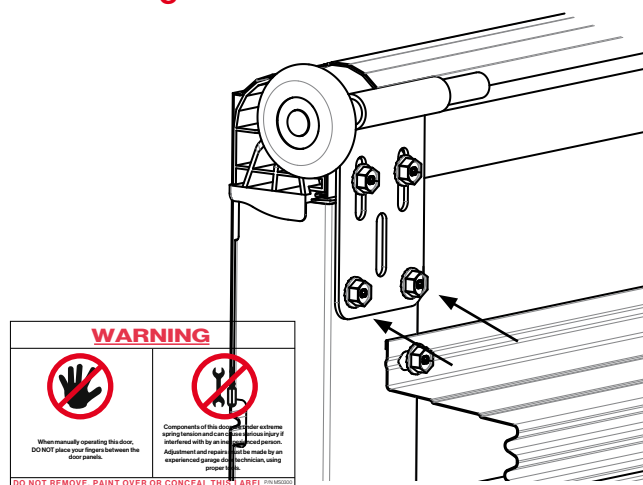

Fig: 3.2.4

### 3.3 fitting reinforcing

**! WARNING!** Doors wider than 3505mm require panel reinforcing. Failure to do so can cause damage to the panels.

The number of reinforcing required for each door is listed in the table 3.3.3.

Reinforcing always starts on the top panel. depending on the number of panels, there may be some panels without reinforcing.

- ! tip**
- 1 reo = top panel
  - 2 reo = top + bottom panel
  - 3 reo = top + bottom panel + middle panel
  - 4 reo = top + bottom panel + middle panels

The reinforcement is generally fixed across the centre of the panel, however there are two situations that require alternative placement.

Senario	Placement
top panel with automatic opener	fit reinforcing as high as possible
top panel with windows	fit reinforcing as high as possible

- a) Determine how many reinforcing bars are required using table 3.3.3.
- b) Secure the panel reinforcing bar © to the top panel with 2 screws per stile as per Fig 3.3.1.
- c) Fit 1 x reinforcing end cap ④ to each exposed end of the reinforcement bars (2 end caps per reinforcement bar). Fig. 3.2.2
- d) As per the tip, if a second reinforcement bar is required, fit it to the bottom panel; any further bars can be fitted to the middle panels.

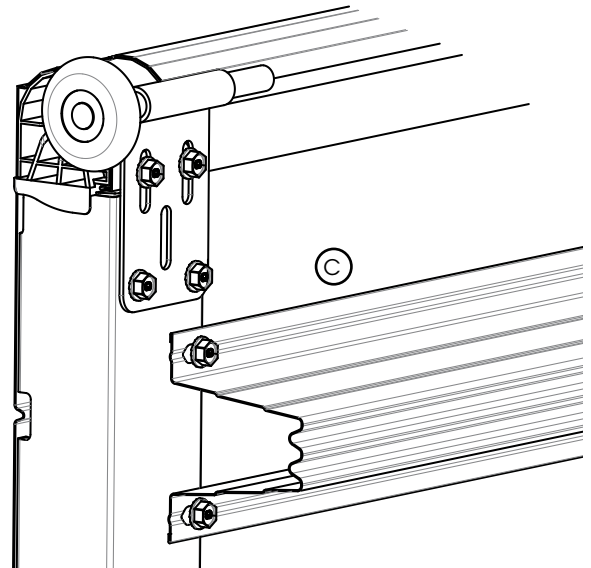

Fig: 3.3.1

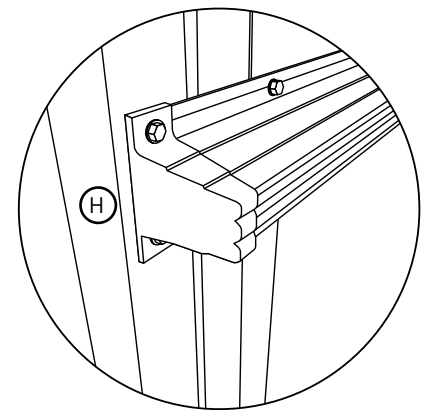

Fig: 3.3.2

panel count	width ranges (from - to, mm)										
	1750 - 3050	3055 - 3500	3505 - 4500	4505 - 4705	4710 - 5000	5005 - 5400	5405 - 5600	5605 - 5740	5745 - 5800	5805 - 6000	6005 - 6600
3	0	0	1	2	2	2	2	2	2	2	3
4	0	0	1	2	2	2	3	3	3	3	4
5	0	0	1	2	2	3	3	3	3	4	5

Table: 3.3.3

### 3.4 installing horizontal tracks

Assemble the track as shown in Figure 3.4.2, ensuring that the top bearing brackets (S) are level and the curve is aligned and butts up against the vertical track snugly.

Before bracing the horizontal tracks, ensure that they are square to the opening and level. To check whether your diagonals are equal:

- Measure from the top of the vertical track to the end of the horizontal track. Fig.3.4.1.
- Check both sides.
- Adjust if necessary.

The track support must be located along the horizontal track approximately at  $\frac{2}{3}$  door height. For doors higher than 2280mm and/or wider than 5000mm two supports will be required.

**! WARNING! Failure to position supports approximately  $\frac{2}{3}$  door height along the track can result in the tracks twisting out.**

- Calculate the horizontal track brace position as per section 1.4.2.
- Measure along the horizontal track to the desired position and find a structurally sound location to fix your support to the ceiling or side wall. Fig 3.4.1.
- Each installation must be assessed individually for ceiling fixing requirements.

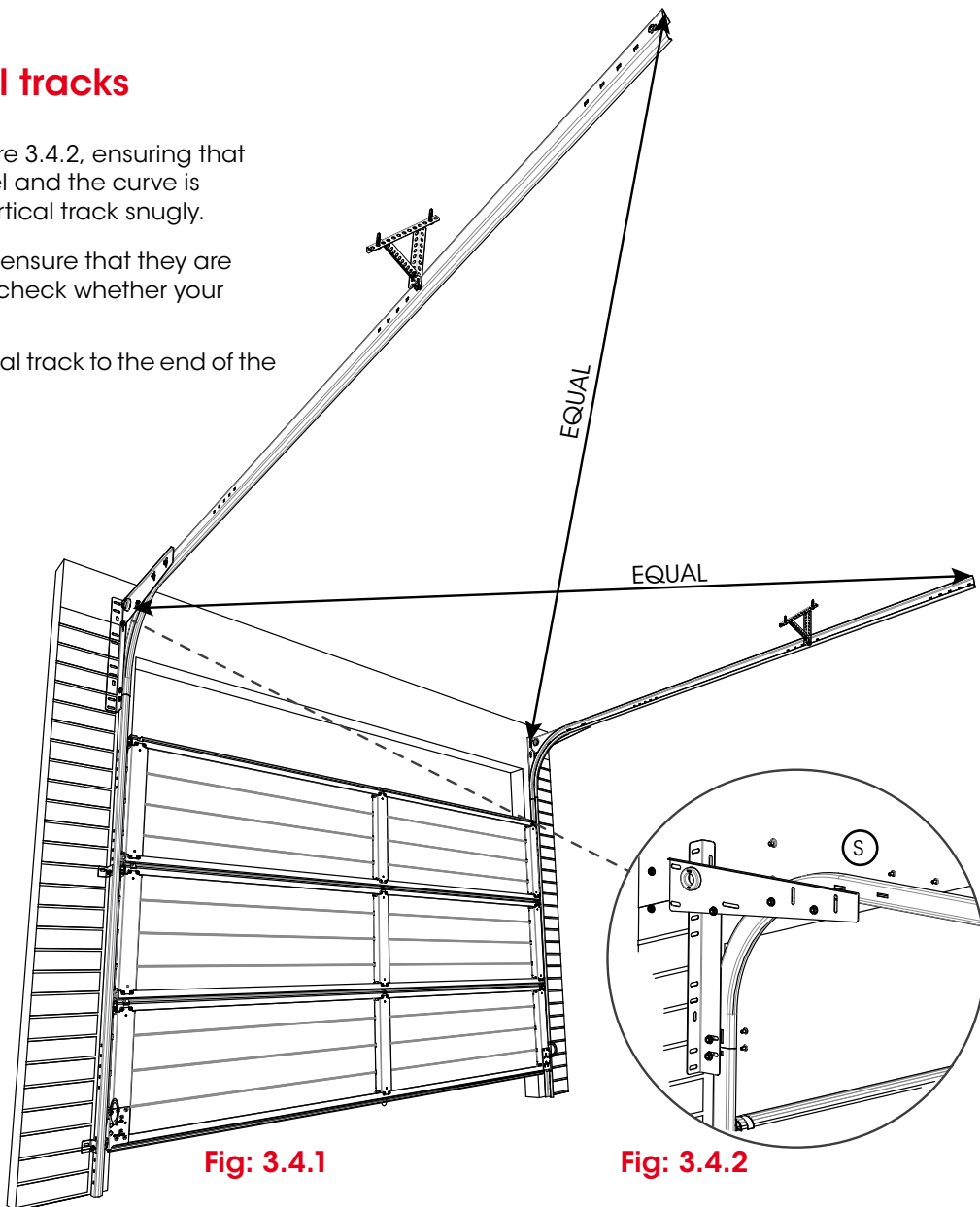

Fig: 3.4.1

Fig: 3.4.2

**! tip** Check that the clearance in the vertical tracks as per Fig 3.1.2 is also in the horizontal tracks

The safety stop must always be fitted to prevent the panels from accidentally exiting the track

- Install the safety stop at the end of the horizontal track as shown in Fig 3.4.2.

**! WARNING! The safety stop must be installed. Failure to do so may cause serious personal injury or damage to property.**

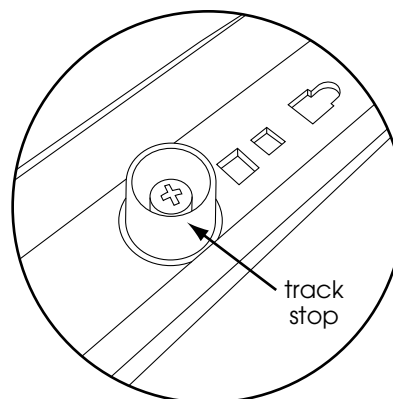

Fig: 3.4.3

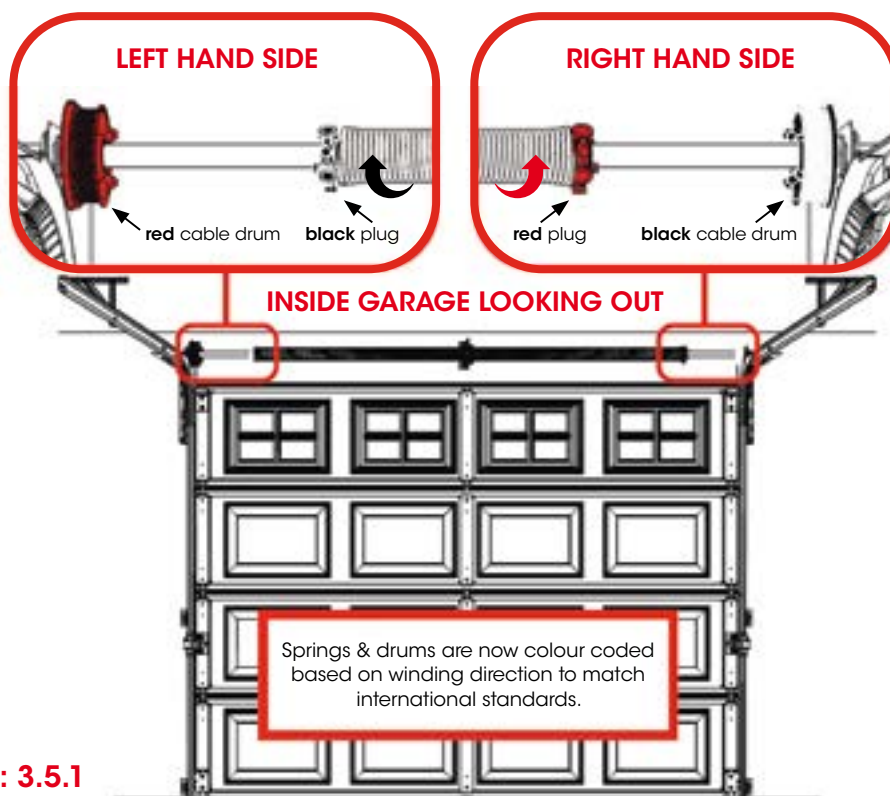

Fig: 3.5.1

### 3.5 standard spring counterbalance system

The springs and drums for the counterbalance system are now colour coded to easily identify which side of the centre bracket the spring is placed. Fig. 3.5.1.

- Place the torsion bar (B) on the floor and slide the spring anchor bracket (Q) onto the torsion bar, positioning it approximately half way along.
- Locate the cable drum/s (I), spring/s (G), shaft collar (P) and washers (F) and assemble them as shown in Fig. 3.5.2.

**NOTE:** Shaft Collar not required in double spring mountings.

- Ensure the shaft collar is butted up against the anchor bracket and fixed to axle on spring side of anchor bracket.

**CAUTION:** DO NOT tighten bolts in cable drums yet

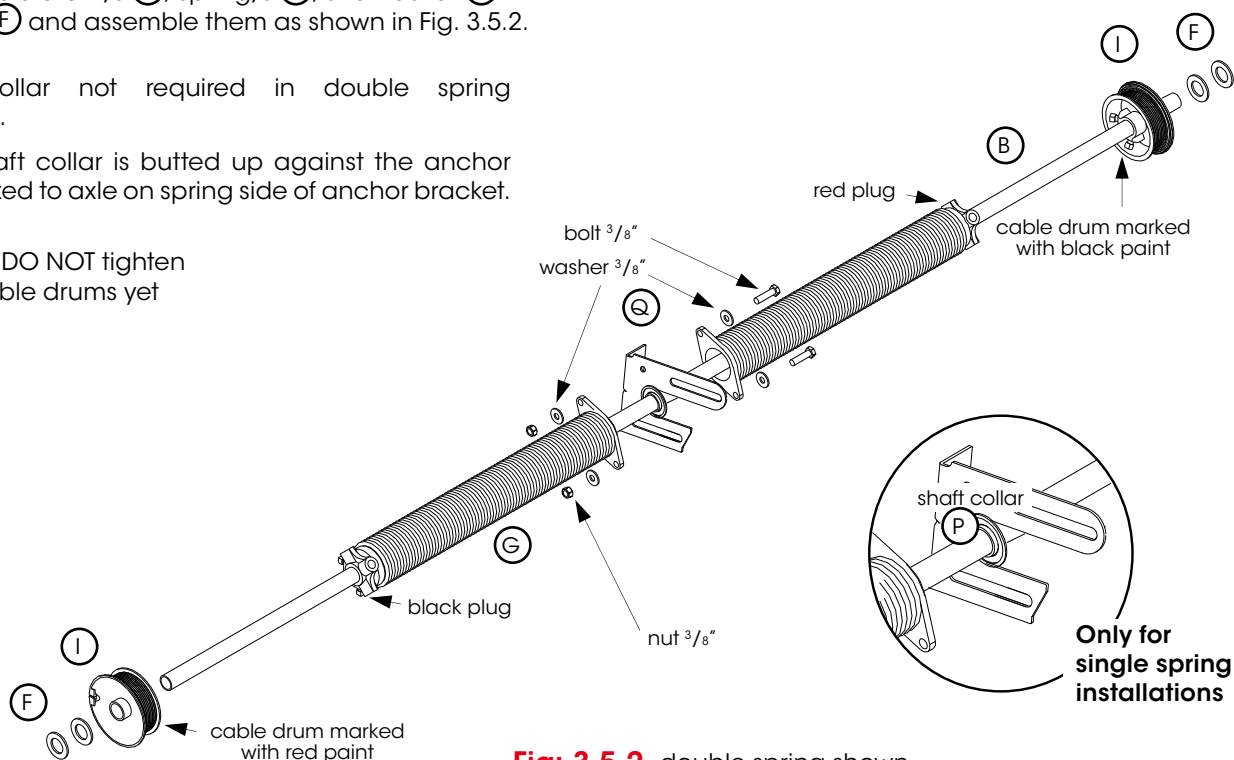

Fig: 3.5.2 double spring shown



### 3.6 install torsion bar

Before lifting the torsion bar into position, check there is a solid foundation of either brickwork, timber studs, head or ceiling that will support the lifting system correctly.

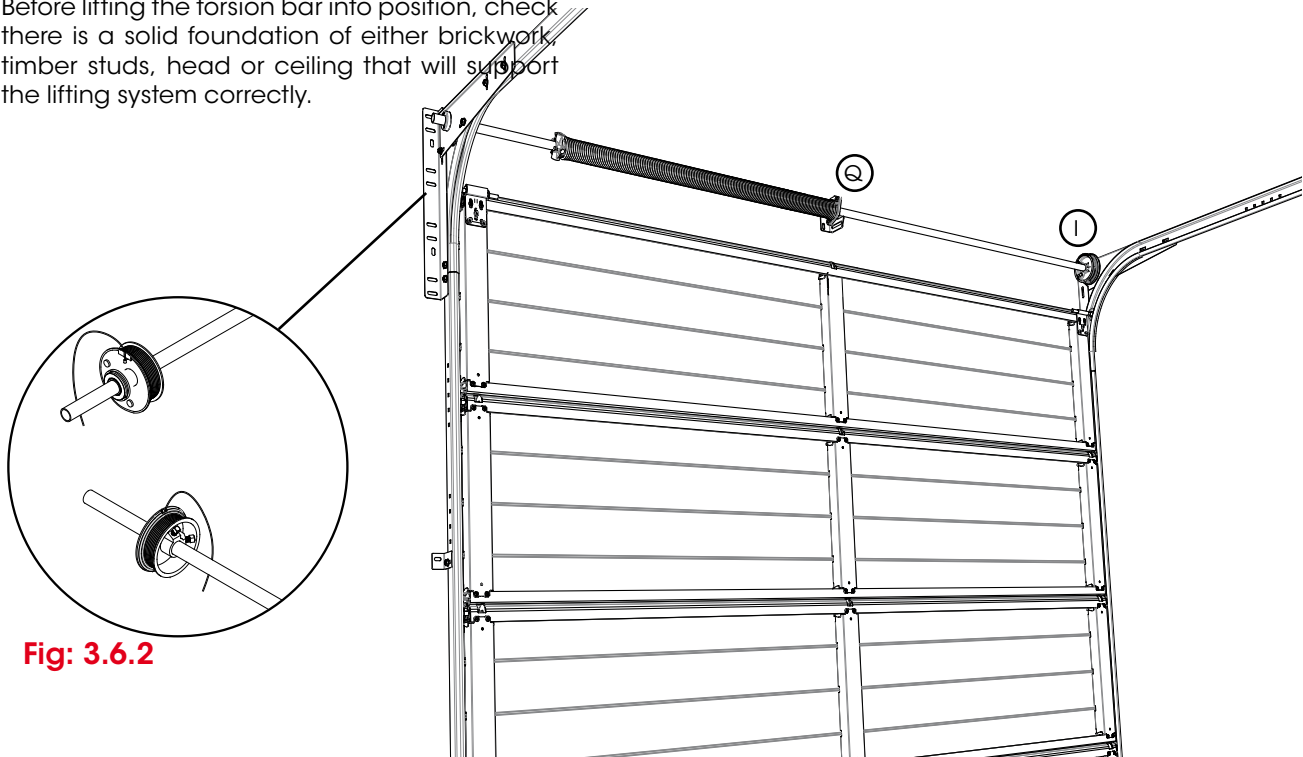

Fig: 3.6.2

Fig: 3.6.1

- Lift the torsion bar assembly into position, inserting both ends into the slots in the vertical track. Fig. 3.6.1.
- Ensure that the cable drums (I) are situated on the inside of the vertical tracks.
- Line up the spring anchor bracket (Q) with the middle of the door, so that the cut corner is facing down and the bracket can touch the wall (the axle must be parallel with the opening).
- Secure the spring anchor bracket to the wall/ceiling as shown in Fig 3.6.1.
- Attach the lifting cable to the cable drum by slipping the cable into the slot on the outside groove. (the ferrule will prevent the cable from coming out) Fig 3.6.2.
- Wind the cable by hand by turning the cable drum away from the door.
- Once the cable is taut, slide the cable drum against the track and tighten the screws to the torsion bar. Fig 3.6.3.

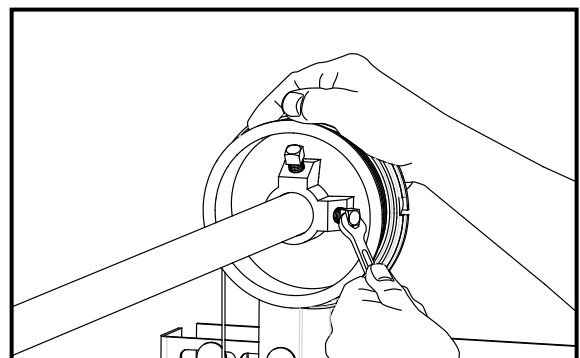

Fig: 3.6.3



**CAUTION:** Be careful not to over tighten the set-screws

### 3.7 adding tension to spring

**WARNING!** Torsion springs can cause serious injury. DO NOT underestimate the tension in the spring.

**WARNING!** Keep hands clear of the spring and the spring winding plug at all times.

The number of turns required for each spring is shown on a paper tag attached to the springs. Fig 3.7.1

- Secure the torsion bar using 2 pipe wrenches as shown in Fig 3.7.2.
- Turn the spring by inserting winding bars into the plug holes of the spring and wind up in the direction towards the opening. Fig 3.7.3.

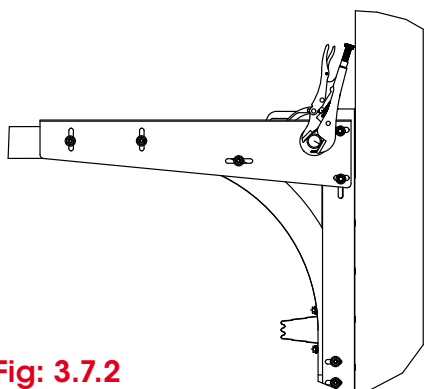

Fig: 3.7.2

**WARNING!** Always have one winding bar engaged and firmly held while turning and tightening screws.

- Once you have completed the turns required, remove one winding bar. If spring snaking occurs, tap the remaining bar back towards the spring anchor bracket.
- Maintain firm tension on the winding bar, while using a spanner to tighten the two (2) grub screws. Fig 3.7.4.

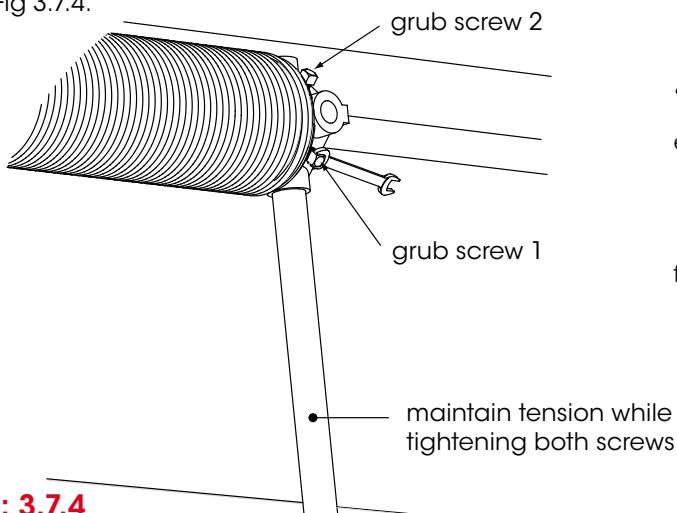

Fig: 3.7.4

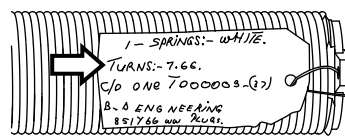

Fig: 3.7.1



The label lists how many full turns. Alternatively, a line is painted along every spring. If the spring is turned 8 times, 8 lines can be seen along the spring

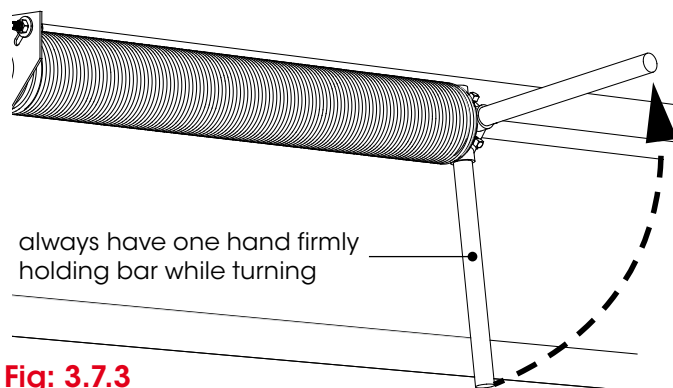
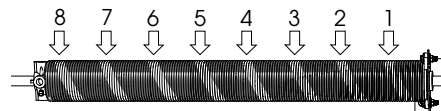

Fig: 3.7.3

**CAUTION:** Be careful not to over tighten the grub screws.

- Repeat this procedure if there is more than one spring, remembering to always wind the spring, whether left or right hand, in an up direction towards the opening.
- Check that all screws are properly tightened before removing the wrenches on the torsion bar.

### 3.8 final checks

For optimal performance the door needs to operate efficiently.

- a) Manually move the door up and down, the door should move freely without binding or sticking.
- b) The maximum force required to move the door should not exceed 20kg.
- c) Lift the door to about halfway. When released, the door should stay in place. Fig 3.8.1.
- d) Check that the clearances in the vertical tracks as per Fig 3.1.2 is also in the horizontal tracks.
- e) If you find that the door is binding, open out the horizontal tracks slightly to create the correct tolerance.
- f) Once satisfied that the operation of the door is as near perfect as possible, check that all nuts and bolts are tight.
- g) Oil the springs full length to prevent noise and reduce friction. TAL 5 or similar oil rich lubricant in a pressure spray can is acceptable. Fig 3.8.2

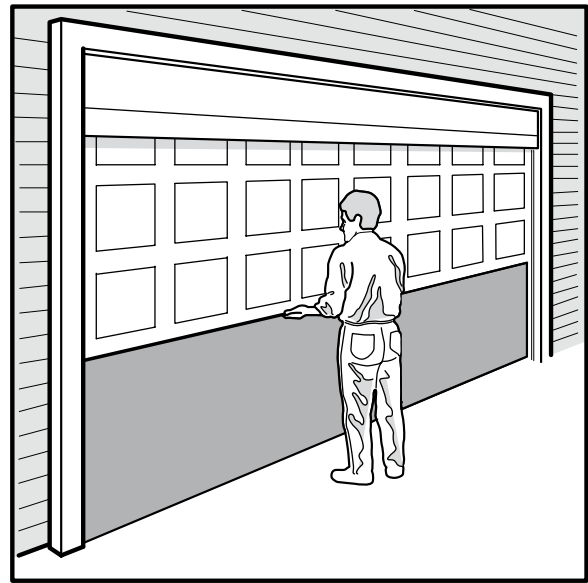

**Fig: 3.8.1**

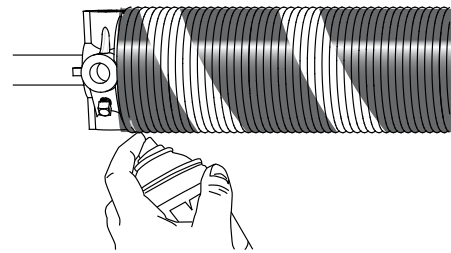

**Fig: 3.8.2**

## 4.0 troubleshooting

Symptom	Possible cause	Remedy
lifting cables loose when door is opened	cable drums have slipped diagonals out of square lifting cables not wound till taut	check the screws on the cable drums check the horizontal tracks are square loosen screws on cable drums and wind cables till taut, then tighten screws.
torsion bar moving	cable drums not adjusted correctly springs not adjusted correctly shaft collar not fitted (single spring) end bearing brackets are not straight	check and adjust check spring tension fit shaft collar, see section 3.5. check end bearing brackets are square and vertical
door will not hold up in open position	spring tension not tight enough incorrect placement of springs panel reinforcing fitted incorrectly	check the correct number of turns has been made to spring/s. refer to section 3.7. check the springs are on the correct side/s, refer to section 3.5. check the reinforcing is placed in the correct position, refer to section 3.3.
door not level	water level marks incorrect lifting cable not equally taut	check the water level marks are correct loosen screws on cable drums and wind cables till taut, then tighten screws.
door moving to one side	clearances incorrect cable drums not close to end bearing brackets	check the clearance/overlap of the door is equal on each side. loosen screws on cable drums and ensure they are hard up against the end bearing bracket and tighten screws.
door panels jamming / rubbing on tracks	incorrect clearance between wheel and vertical track door not level cable drum not lined up correctly vertical tracks not parallel lifting cables slipping	Check that the clearances per Fig 3.1.2 are the same in both vertical and horizontal tracks. check water level marks are correct. loosen screws on cable drums and ensure they are hard up against the end bearing bracket and tighten screws. Check that the clearances per Fig 3.1.2 are the same on both vertical tracks. loosen screws on cable drums and wind cables till taut, then tighten screws.
door hard to lift	spring tension spring may have slipped on set screws wrong spring panel reinforcing	check the correct number of turns has been made to spring/s. refer to section 3.7. check spring plug grub screws are tight, refer to section 3.7 check the springs are on the correct side/s, refer to section 3.5. check the reinforcing is placed in the correct position, refer to section 3.3.

## common spring problems

symptom	possible cause	rememdy
door raises from the floor and hangs down in opening	cable length too long with cable not on high portion of drum	shorten cable length until the cable rolls onto the flat portion of the drum when the door starts into the horizontal position
	springs may be too strong (too short)	replace spring
	wrong cable drums for springs (too small)	replace cable drums
door lifts from the floor and runs away at the top	door is over tensioned, too many turns on spring or wrong spring	ensure that the correct spring is supplied (if not replace) and that it has the correct number of turns applied
	wrong cable drums for spring, (too small)	replace cable drums
door falls to the floor and hangs down in the opening	door is under tensioned too few turns on spring or wrong springs	ensure that the correct spring is supplied (if not replace) and that it has the correct number of turns have been applied
	wrong cable drums for springs (too large)	replace cable drums
door falls to the floor and runs away at the top	lifting cable may be too short for high lift cable drum or vertical lift drum and is sitting too high on the spiral portion of the drum	increase the cable length to bring the cable down lower on the spiral
	torsion springs too long	shorten springs
door balances at the floor but runs up or down in between	cables in wrong position on spiral of the drums	adjust cable length
poor balance throughout	winding spring in wrong direction	wind in correct direction
	door weight incorrect	supply correct springs
	springs binding	fit torsion bar collar lubricate springs
	door not level	cable lengths are equal equal turns on both springs level door during installation

## 5.0 appendix

### 5.1 hinged tapers

Tapers are accomplished using a small customised panel, which results in a slight variation in the installation process.

- Assemble the tapered panel as shown in Fig 5.1.1 with the 2 spacers required being cut to 10-12mm long from a white link pin and fitted one to each side.
- Assemble the bottom panel taking note that the bottom hanger sits slightly higher up the panel than normal, so as not to interfere with the hinging movement. Fig 5.1.2
- There are also no wheels or weather strip on the bottom panel, these are both on the taper panel.

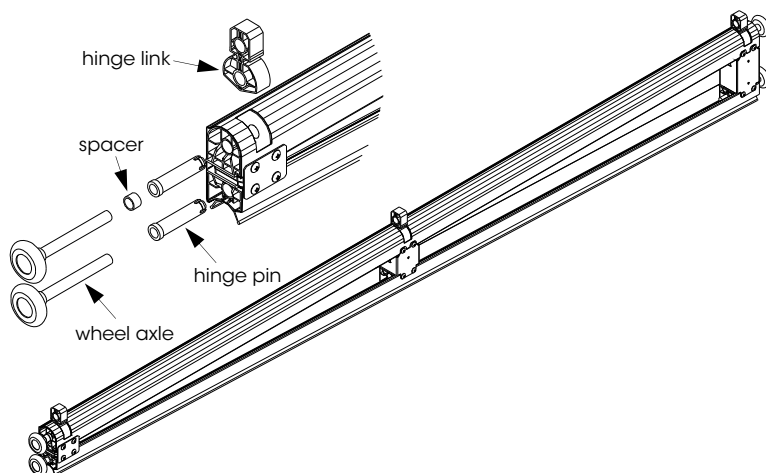

**Fig: 5.1.1**

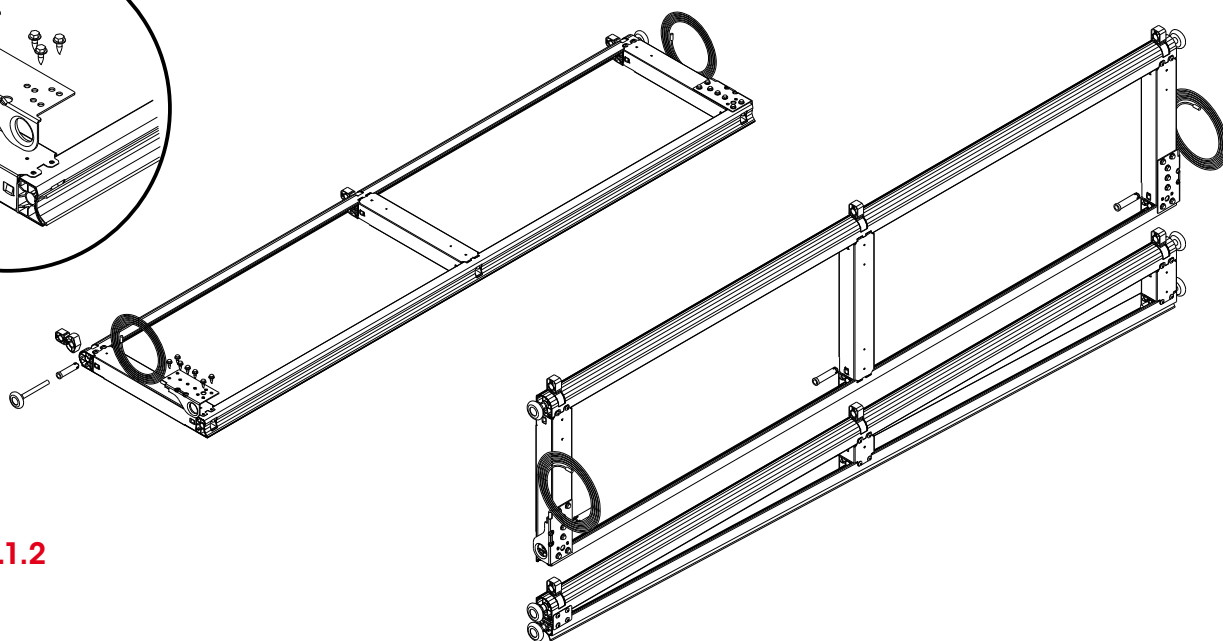
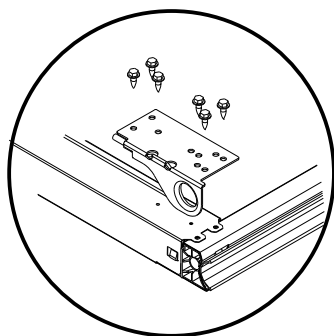

**Fig: 5.1.2**

Tracks are assembled as standard with the only difference being that one vertical track needs to be cut down to accommodate the uneven floor.

- Start with both of the verticals tracks from the ground and measure up to the level datum.
- Cut the tracks as necessary from the ground end.
- Follow the directions in section 3.1 to install tracks, before proceeding to adding panels in section 3.2.

## 5.2 after installation care

### general care of your Paneliff®

#### cleaning

##### COLORBOND® & COLOURED STEEL FINISH

Your B&D Paneliff® has been pre-painted with a high durability polyester paint system, especially designed and tested for the harsh Australian conditions. However, all exposed surfaces require some attention to guard against the premature onset of corrosion and any other harmful atmospheric effects. In our atmosphere there are harmful deposits that gather on the door surface and if not removed regularly, will seriously affect the appearance and life of the door.

Washing of the door with clean water and a cloth every 14 days is recommended – particular care should be taken to clean areas of the door not normally washed by rain.

#### lock

Your lock does not require special maintenance, however, if the keyway becomes stiff, the application of powdered graphite is recommended – do not grease or oil the lock.

**WARNING!** Do not disassemble the lock mechanism and do not allow paint to enter the lock keyway.

#### hinges & hangers

**PLASTIC HINGES:** No lubrication is generally required, however silicon spray or lithium grease may be used if necessary.

#### cables

Check the cables regularly for corrosion, fraying or tangling, if any of these are evident call your service provider.

### regular maintenance required

B&D recommends that you check the operation of your Paneliff® at least every six months (more regularly in extreme environments or frequent use). The effort required to manually open and to manually close the door should be about the same (if door has an automatic opener, put into manual mode before testing door).

If the door is difficult to operate in either direction (up or down) then check that the inside surfaces of the guides are clean and free of obstructions.

If the door is still difficult to operate, then your door will need a service to adjust the spring tension and possibly other operational parts of the door.

This service should only be carried out by an experienced door technician, using the correct tools.

If you have an automatic opener fitted to your door, it is particularly important that you ensure the optimum operation of the door, otherwise you may reduce the effective life of the opener.

To keep your door running well, it is recommended that your door be serviced, by an experienced door technician, every 12 months (more regularly in extreme environments or frequent use), or earlier if required.

### spring tension

It is natural for springs to lose tension over time. When spring tension is adjusted or when your door is first installed it is usual to apply a little more tension than is required for balanced operation, to allow for the normal "settling in" of the springs. Lightly lubricate to prevent friction between the coils.

### warranty

Warranty conditional on proper care as recommended above. Full details of the warranty are available in your owners handbook, from your nearest B&D office or visit the B&D website [www.bnd.com.au](http://www.bnd.com.au)

### b&d doors office locations

<b>Head Office</b>	6-8 Fiveways Blvd, Keysborough 3073	Phone (03) 9791 2000
<b>New South Wales</b>	34 Marigold St, Revesby 2212	Phone (02) 9722 5555
<b>Queensland</b>	17 Oasis Court, Clontarf 4019	Phone (07) 3883 0200
<b>Victoria</b>	147-153 Canterbury Rd, Kilsyth 3137	Phone (03) 9237 7766
<b>South Australia</b>	23 Frederick Rd, Royal Park 5014	Phone (08) 8440 4747
<b>Western Australia</b>	96 Mulgool Rd, Malaga 6090	Phone (08) 9247 8777
<b>International/Export</b>	34 Marigold St, Revesby 2212	Phone +61 (0)2 9722 5555

your representative is