

**b&d**

# Tilt-A-Dor®

## T-Fitting

installation instructions

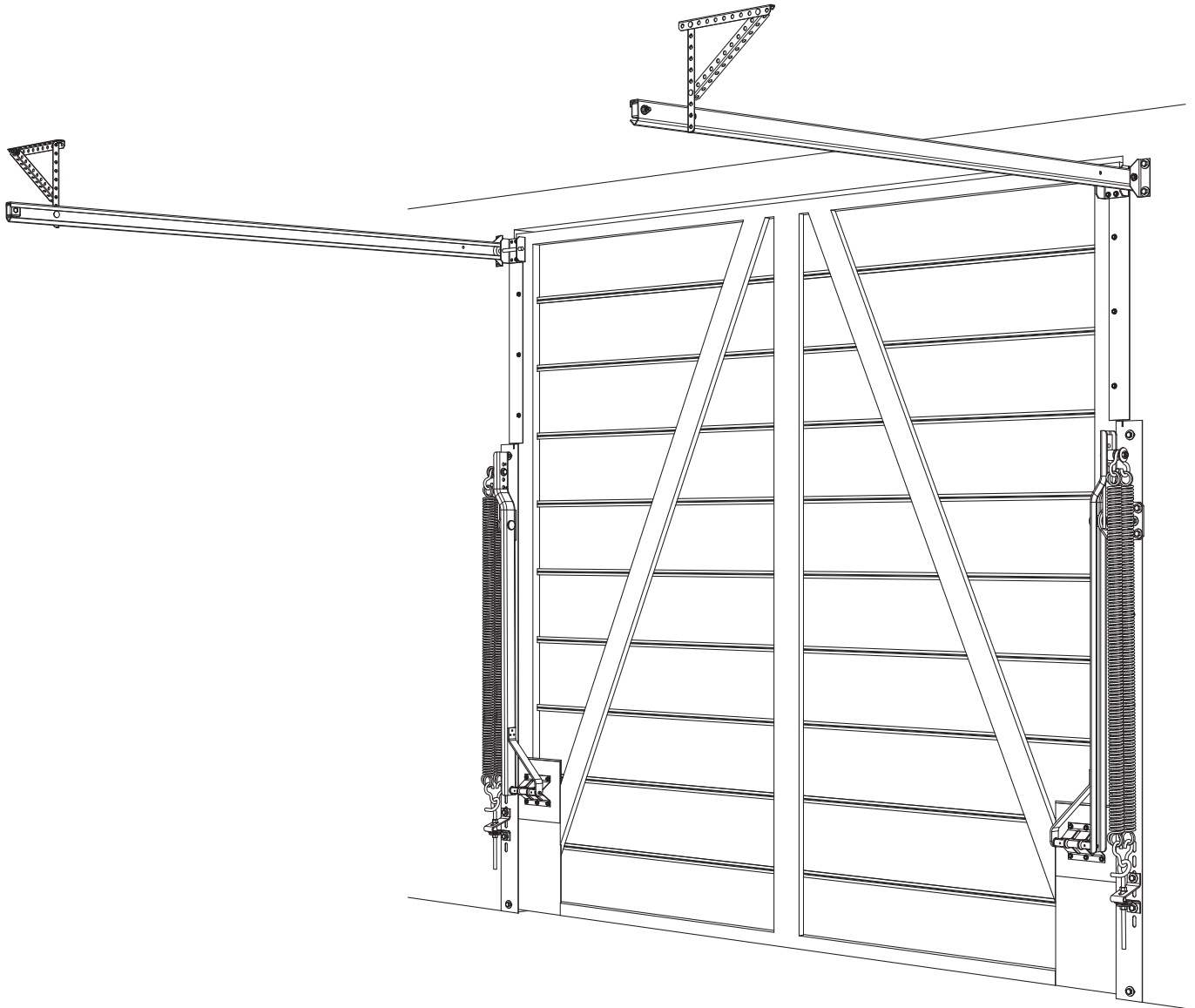

These instructions are intended for professional garage door installers. All references are taken from inside looking out.

REVISION 6 - OCTOBER 2016

[www.bnd.com.au](http://www.bnd.com.au)

**b&d**

## contents

<b>1.0</b>	<b>before you start</b>	<b>3</b>
1.1	safety checklist	3
1.2	fastener recommendations for fitting garage doors	4
1.3	tools checklist	5
1.4	checking measurements	5
1.5	check t-fitting model	6
<b>2.0</b>	<b>installation</b>	<b>6</b>
2.1	installing top weatherstrip and wheel	6
2.2	placing panel into position	7
2.3	installing tracks	7
2.4	installing weather strip and power arm	9
2.5	lifting and securing door	10
2.6	spring assembly	11
2.7	final adjustments	12
<b>3.0</b>	<b>after installation care</b>	<b>13</b>

# 1.0 before you start

## 1.1 safety checklist

The following hazards and hazard controls have been identified for installers during the installation of these fittings.

hazard	control
<ul style="list-style-type: none"> <li>Housekeeping - <b>risk of slip trip or fall</b></li> <li>Housekeeping - <b>risk of injury to other people</b> or animals in the installers work area</li> </ul>	<ul style="list-style-type: none"> <li>Tidy up site prior to start work as a minimum area should be at least the area of the installation back into the garage and 2 metres in front</li> <li>If the Site housekeeping is deemed to be unsafe do not install the door</li> <li>Keep all people well clear of installers work area with appropriate signage and discussion with owner</li> </ul>
<ul style="list-style-type: none"> <li>Weight &amp; awkwardness of lifting of springs and fittings</li> <li>Manual handling when moving the fittings from the Trailer or Ute to the installation area - <b>risk of musculoskeletal injury</b></li> <li>Manual handling when installing Doors &amp; Openers particularly above head height - <b>risk of musculoskeletal injury or twisting</b></li> <li>Manual handling when installing springs, tracks and torsion bars - <b>risk of musculoskeletal injury</b></li> </ul>	<ul style="list-style-type: none"> <li>Utilise correct lifting techniques for springs and fittings.</li> <li>Use of 2 person lifts</li> <li>Use of mechanical aids</li> <li>Avoid twisting (practice correct lifting techniques)</li> <li>Correct use of ladders while installing tracks</li> </ul>
<ul style="list-style-type: none"> <li>Working at heights and working with ladders - <b>risk of fall from height</b></li> </ul>	<ul style="list-style-type: none"> <li>Ladder check</li> <li>Ladder placement</li> <li>Do not work off the top rung</li> </ul>
<ul style="list-style-type: none"> <li>Sharp edges on tracks or related jewellery - <b>risk of laceration</b></li> </ul>	<ul style="list-style-type: none"> <li>Wear appropriate PPE (Dyneema cut off gloves)</li> </ul>
<ul style="list-style-type: none"> <li>Pinch points - <b>risk of cut, puncture or crush injury</b></li> <li>Scissor action of fittings - <b>risk of laceration</b></li> </ul>	<ul style="list-style-type: none"> <li>Wear appropriate PPE and keep hands well clear of pinch points</li> <li>Ensure hands well clear of the panels</li> <li>Follow instruction explicitly particularly for the installation as the scissor action of some fittings presents a very sharp edge</li> </ul>
<ul style="list-style-type: none"> <li>Use of hand tools - <b>risk of eye injury, laceration cut stab or puncture injuries (Tools checklist)</b></li> <li>Use of Electric/ Battery or pneumatic tools - <b>noise hazard</b></li> <li>Use of cutting tools creating sparks - <b>risk of fire</b></li> </ul>	<ul style="list-style-type: none"> <li>Wear appropriate PPE and utilise operators manual</li> <li>Use appropriate noise/hearing protection in the form of ear plugs or ear muffs</li> <li>Ensure appropriate fire protection available and housekeeping to ensure that flammable liquids or materials are removed from the area of work</li> </ul>
<ul style="list-style-type: none"> <li>Spring release of energy - <b>risk of release of stored energy (striking installer on the head or body)</b></li> </ul>	<ul style="list-style-type: none"> <li>As the spring is at it greatest tension during the time the door is being opened or closed - <b>correct fixings and correct fittings MUST be used</b> during every installation. Including the number of bolts to be used, the equaliser plate, clover hooks, pigtailed bolt and spring anchor bracket. These have been specifically designed to ensure that the spring is held in place at all times</li> <li>The <b>correct sized door MUST be used</b> for the recommended springs</li> <li>The <b>owner MUST be informed</b> of maintenance requirements</li> </ul>

## 1.2 fastener recommendations for fitting garage doors

material	fastener type(s)	diameter or type		length of fastener (see note)
New Solid Brick	Coach Bolts (Hex Lag Screw) - combined with wall plugs	5/16"	X	1½"
		3/8"	X	2"
	Macplugs (wall plugs) to suit above	5/16"	X	50mm
		3/8"	X	60mm
	HLC Sleeve Anchors (Dyna Bolts)	12mm	X	55mm
New Hollow Brick	HRD-VGK or HGK-VGS (Hex Head) Frame Anchors	10mm	X	60mm
New Solid Concrete	Coach Bolts (Hex Lag Screw) - combined with wall plugs	5/16"	X	1½"
		3/8"	X	2"
	Macplugs (wall plugs) to suit above	5/16"	X	50mm
		3/8"	X	60mm
	HLC Sleeve Anchors (Dyna Bolts)	12mm	X	55mm
Aerated Concrete e.g. (HEBEL)	Fischer Nylon Twist Lock Anchor Type GB 14	14mm	X	85mm
Steel Framing e.g. BHP Framing (with rear access)	Hex Head Bolt Zinc Plated, Hexagon Nuts Zinc Plated, Washers Zinc Plated	5/16"	X	1"
		3/8"	X	1"
		10mm	X	25mm
		12mm	X	25mm
Heavy Gauge Steel	Hex Head Tek	14-20	X	22mm
Light Steel Framing e.g. BHP House Framing (no rear access)	Heavy Duty Kap Toggle	10mm	X	100mm
		12mm	X	100mm
	Hex Head Tek	6-10	X	20mm
New Timber	Coach Bolts (Hex Lag Screw)	5/16"	X	1½"
		3/8"	X	2"
	Hex Head Tek	14-10	X	50mm

### important notes

- For installation to materials not covered in the above chart, the installer should seek expert advice from a qualified builder.
- Minimum length of fastener does not exclude use of longer lengths. Decision must be made by fitter to ensure adequate strength.
- Recommendations for old materials or materials not in good condition are not included. If in doubt about the strength of the material seek specialist advice.
- Fasteners for sectional door spring brackets and top track brackets in masonry should be at least 5/16" x 2.5" long or metric equivalent.
- HEBEL Fischer type fastener should be installed 150mm from edge of blocks. Minimum overlap of door should be approximately 115mm (S1), 110mm (S3) and 90mm (Panelift). Add 50mm more if mounted on panels instead of blocks.

### important information on fasteners

Coach bolts/screws supplied with this product are suitable for fastening to timber jambs. Correct and safe fastening to other materials may require different fasteners. The installer must select and use fasteners appropriate to the material into which they are being fixed.

### 1.3 tools checklist

The following tools are needed to install Tilt-A-Dor® T-Fitting.

- Spirit level 1200mm
- Measuring tape
- Extension lead
- Step ladder
- Speed drill and drill bits
- Impact drill and masonry bits
- Hack saw
- Open end adjustable spanner
- Set square
- Wood chisel
- Steel chisel
- Screw driver set
- Pliers
- Tin snips
- 2 vice grips
- Felt tip pen & pencil

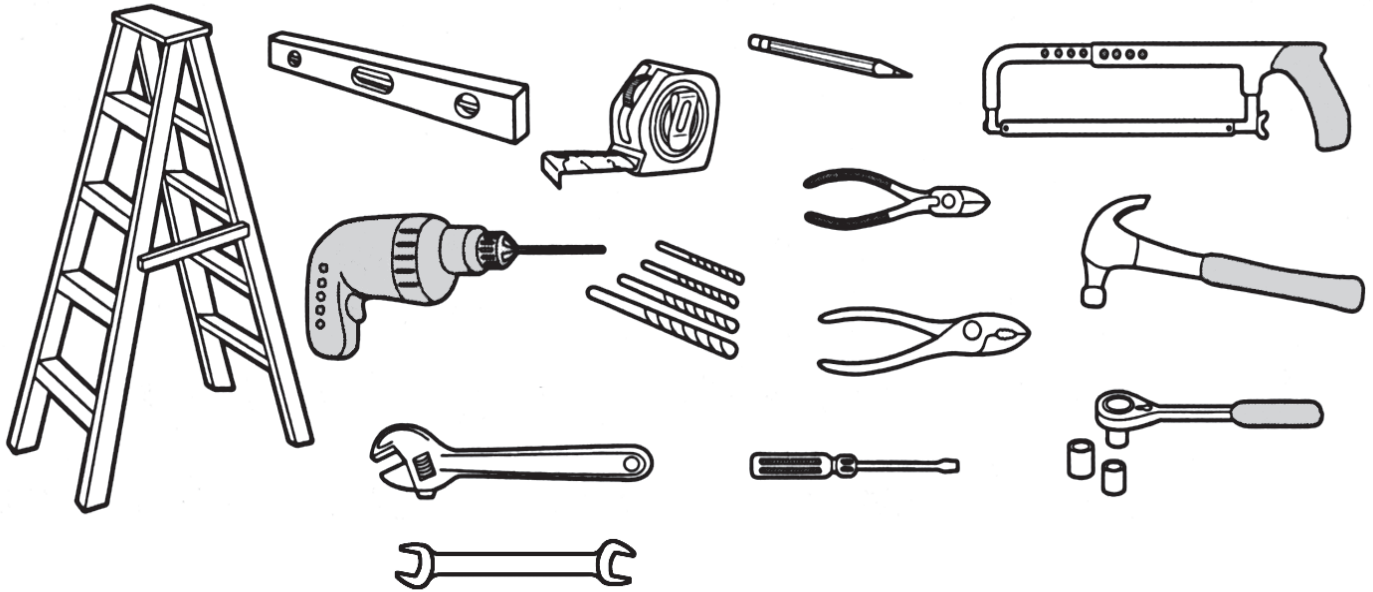

### 1.4 checking measurements

Before proceeding please check the opening measurements against the panel and ensure that the correct fitting has been obtained in regards to door weight.

<b>Door Width</b>	Opening Width - 20mm
<b>Door Height</b>	Opening Height - 27mm
<b>Min. Headroom</b>	50mm for a manually operated door 100mm with an automatic opener
<b>Min. Sideroom</b>	70mm (Model 50-T, 70-T, 100-T, 120-T) 90mm (Model 175-T)

If making jamb out of timber, we suggest using oregon timber.

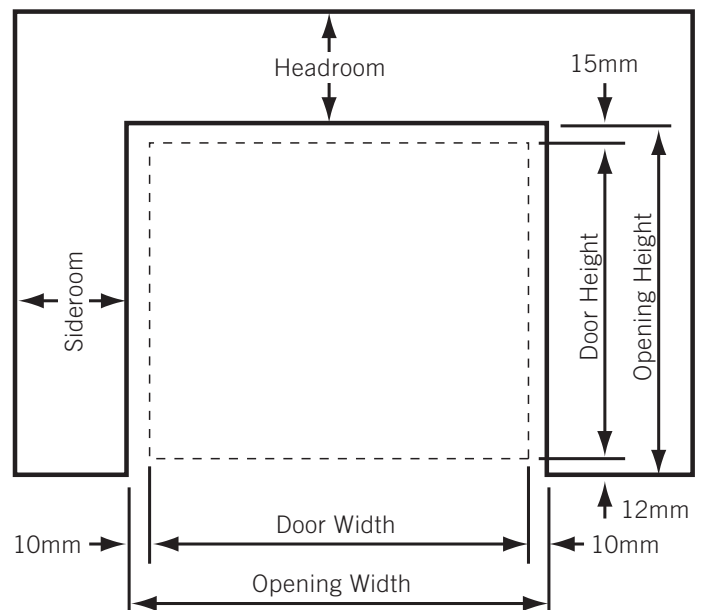

## 1.5 check t-fitting model

Check the T-Fitting against the door measurements and the panel weight on the table below to ensure that the correct fitting has been ordered.

single spring/side					double spring/side					spring specifications			
door height (mm)	2851 min				door height (mm)	3050 max	120-t-3050	175-t-3050	colour				
	2850 max					2701 min	orange spring	orange spring	wire dia.				
	2450 max	70-t-2450	100-t-2450	2700 max		120-t-2700	175-t-2700	spring od					
	2451 min	brown spring	brown spring	2401 min		orange spring	orange spring	active length					
	2250 max	70-t-2250	100-t-2250	2400 max		120-t-2400	175-t-2400	track fitting					
	1951 min	brown spring	brown spring	2101 min		brown spring	brown spring	<b>brown</b>	5.6	41	539		
1950 max	70-t-1950	100-t-1950	2100 max	120-t-2100	175-t-2100	<b>orange</b>	5.6	41	695				
1800 min	brown spring	brown spring	1900 min	brown spring	brown spring								
door weight (kg)	30	70	71	100	door weight (kg)	101	120	121	175				

## 2.0 installation

### 2.1 installing top weatherstrip and wheel

Assemble the top strip onto the panel as shown in Figure 2.1.1. Note that only in the 175-T model fitting is the wheel a separate assembly to the weatherstrip, all other fittings are already assembled. Please note that dimension Y is variable depending on panel thickness, with a minimum of 15mm.

Figure 2.1.1

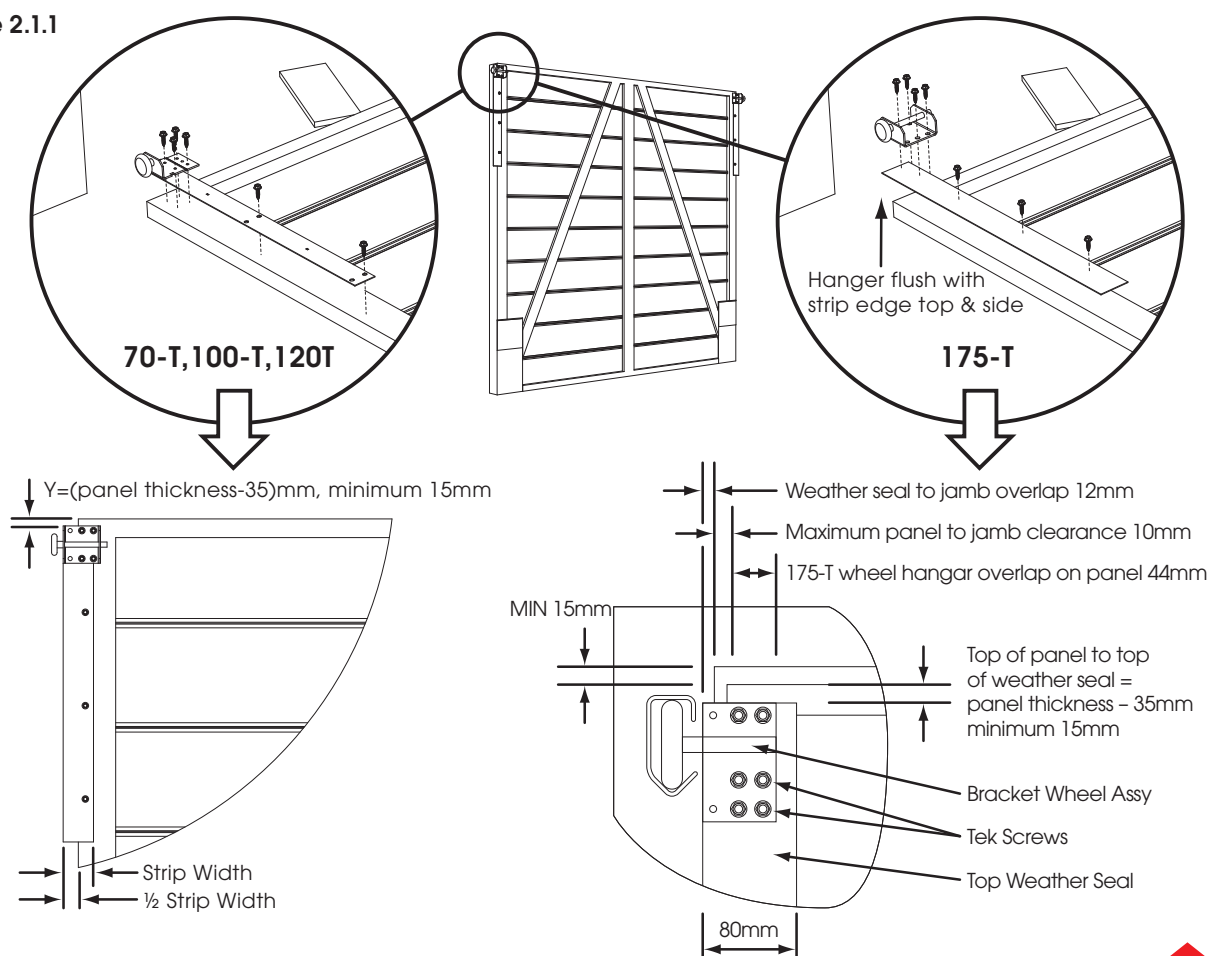

## 2.2 placing panel into position

Place some 12mm spacers at the opening. Lift panel into position as shown. Ensure that the top weatherstrip is flush against the jamb and that the proper clearances are observed as shown in Figure 2.2.1.

Figure 2.2.1

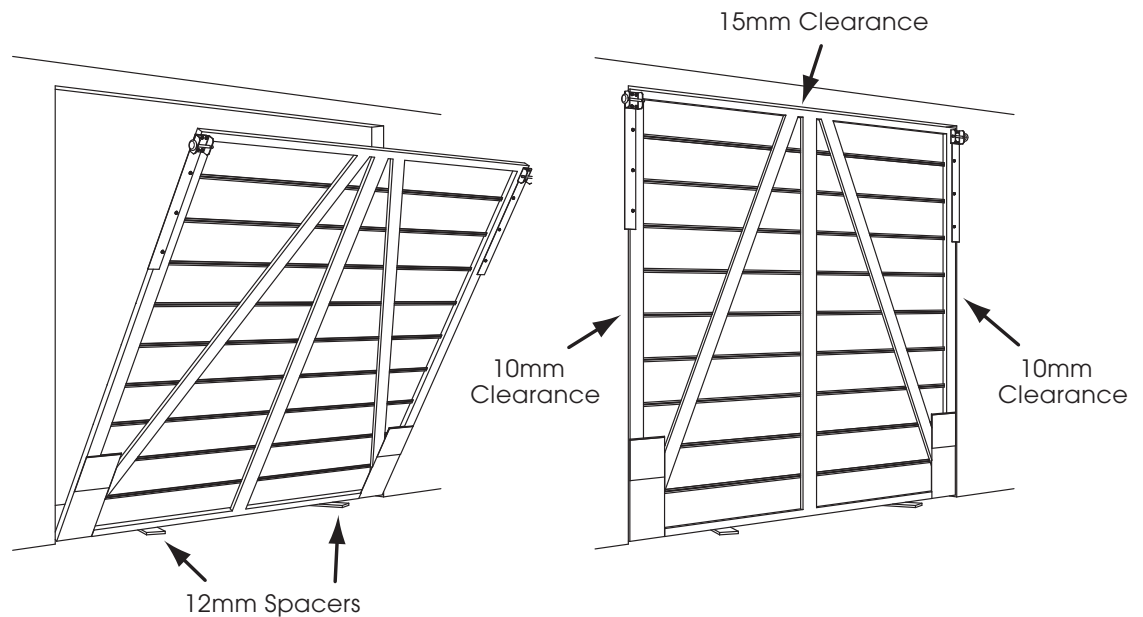

## 2.3 installing tracks

Figure 2.3.1

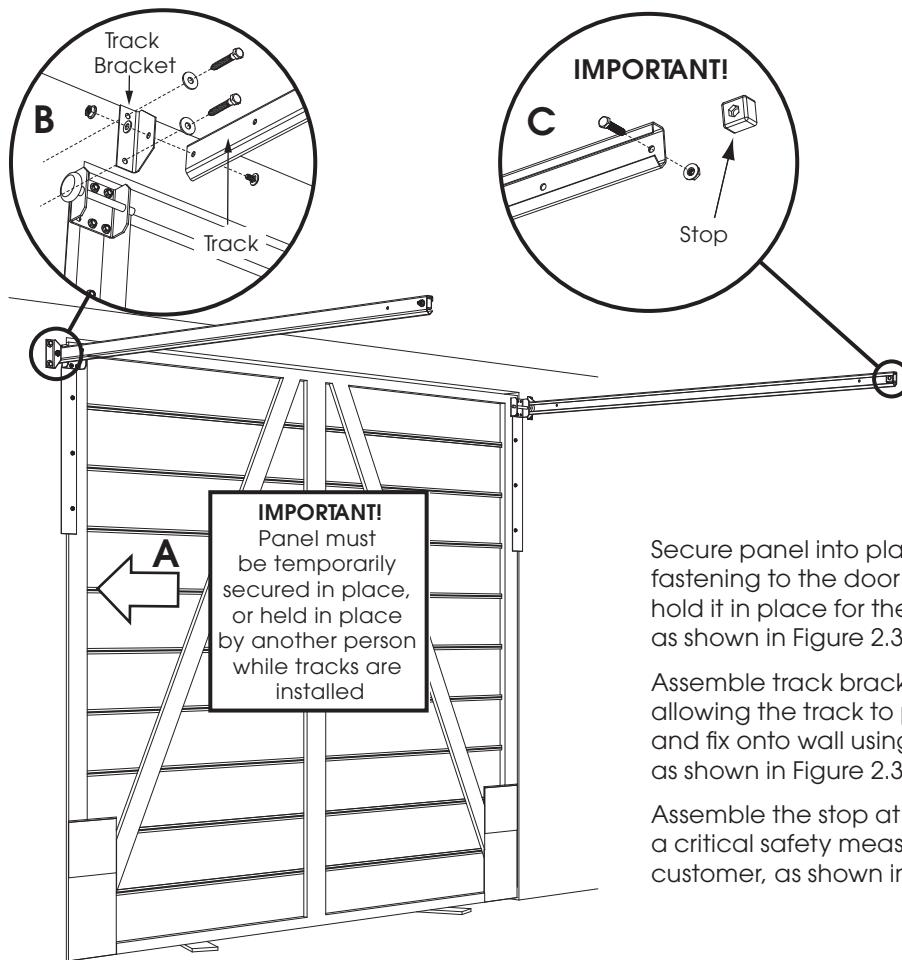

Secure panel into place, either temporarily fastening to the door jamb, or having a helper hold it in place for the duration of this stage, as shown in Figure 2.3.1.A.

Assemble track bracket onto track, but still allowing the track to pivot. Slip over wheel and fix onto wall using appropriate fasteners, as shown in Figure 2.3.1.B.

Assemble the stop at back of the track, this is a critical safety measure for both installer and customer, as shown in Figure 2.3.1.C.

Figure 2.3.2

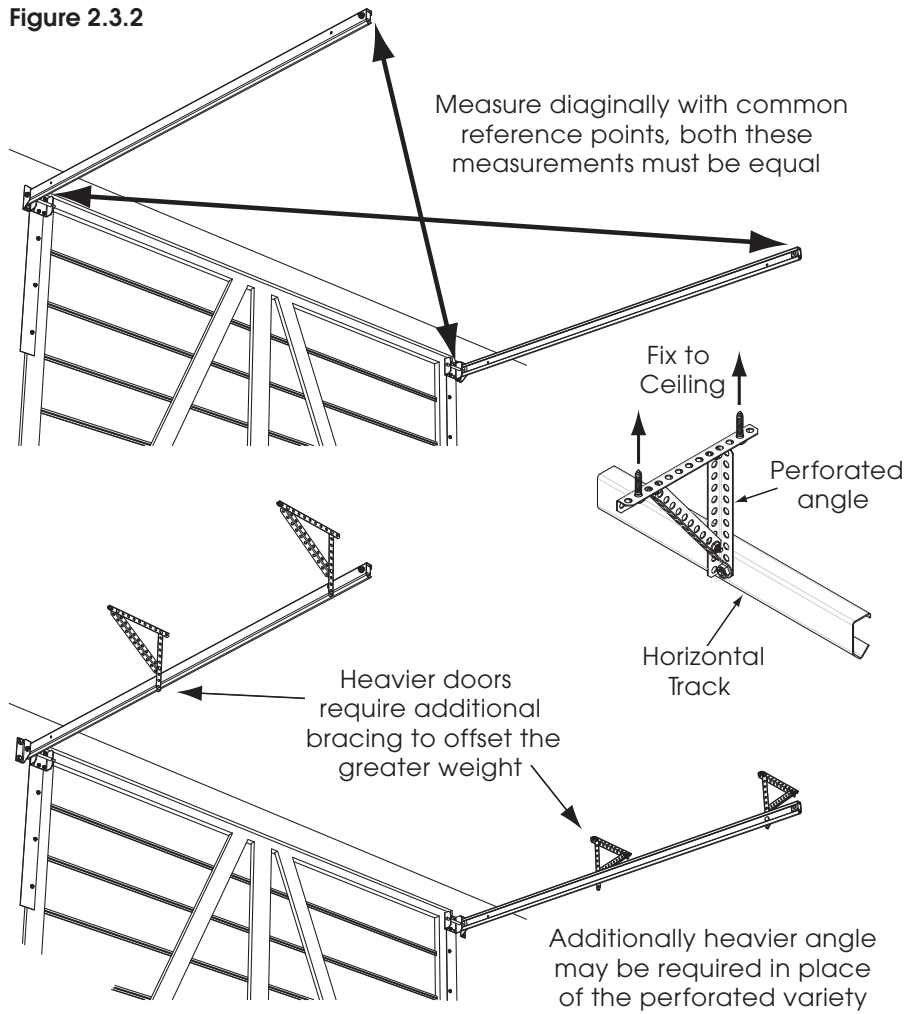

Use some angle to prop up the back track temporarily to the ceiling. Measure from common reference points across the diagonals of the tracks as shown in Figure 2.3.2. These must be equal and the tracks slope down by 33mm for all but the 175-T which should be 50mm, before securing the track bracing Figure 2.3.3.

Figure 2.3.3

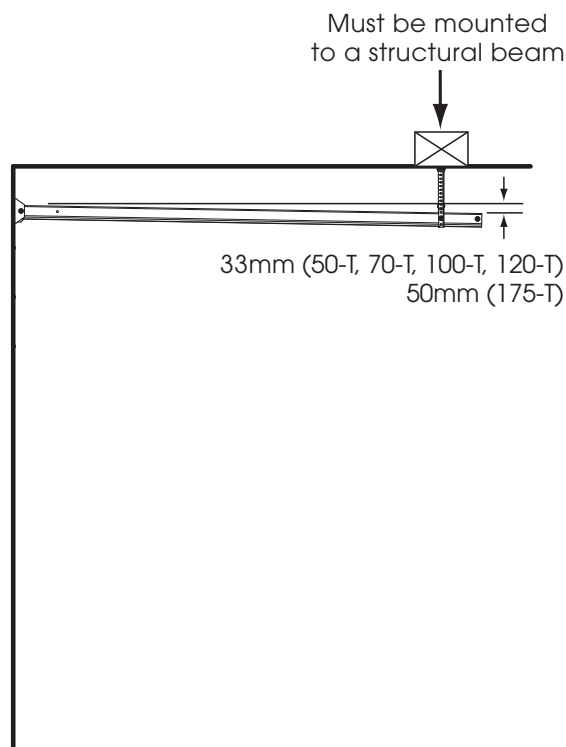

## 2.4 installing weather strip and power arm

Measure the distance from the bottom of the top weatherstrip down to the floor, then cut down the bottom weatherstrip accordingly giving a 3mm clearance between the strip Figure 2.4.1.A. Ensure bottom weather strip is vertical by using a spirit level (Note: Door jambs are not always true).

Align the vertical slot with jamb edge as shown in Figure 2.4.1.B. Use appropriate fasteners to fix to jamb.

Figure 2.4.1

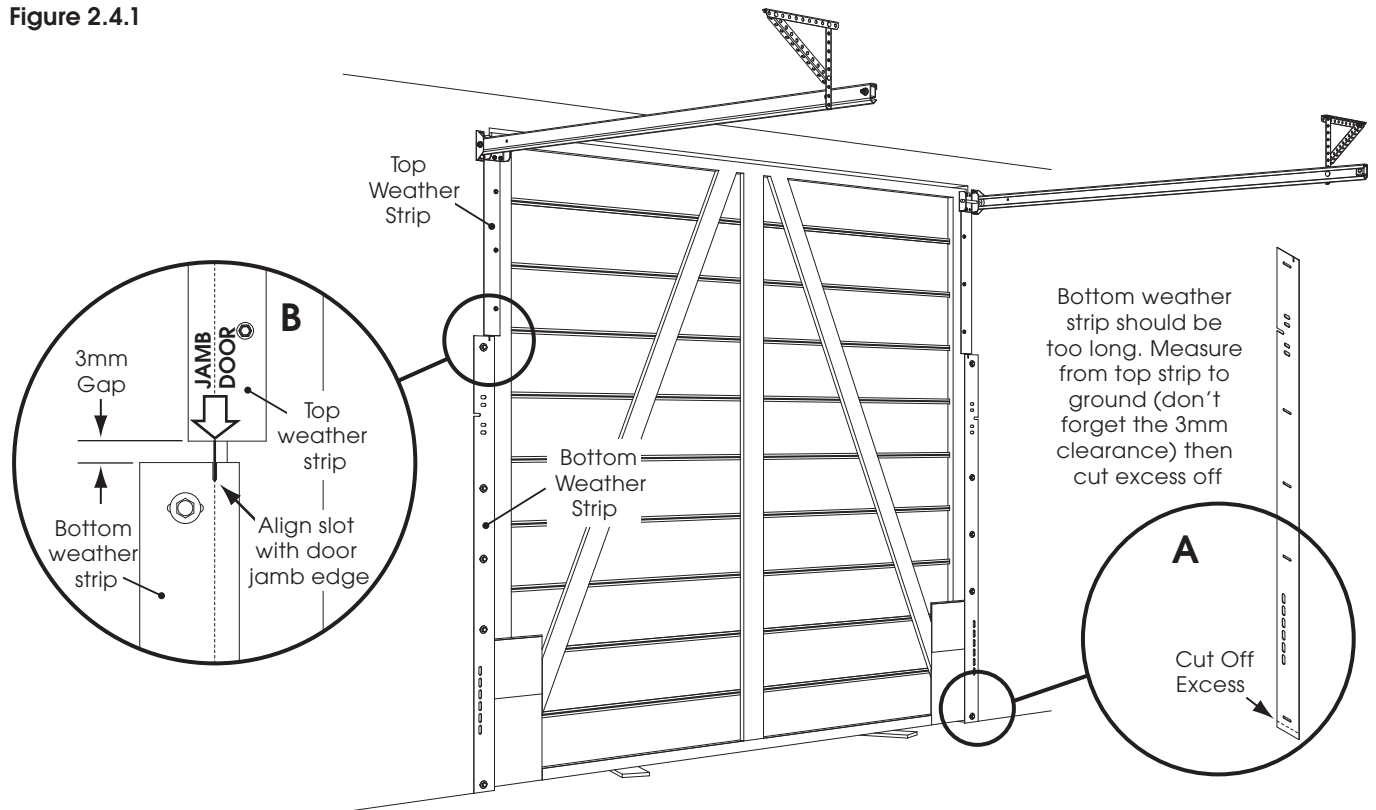

Assemble the power arm onto the bottom weather strip as shown in Figure 2.4.2, aligning holes as shown and power arm as shown.

Figure 2.4.2

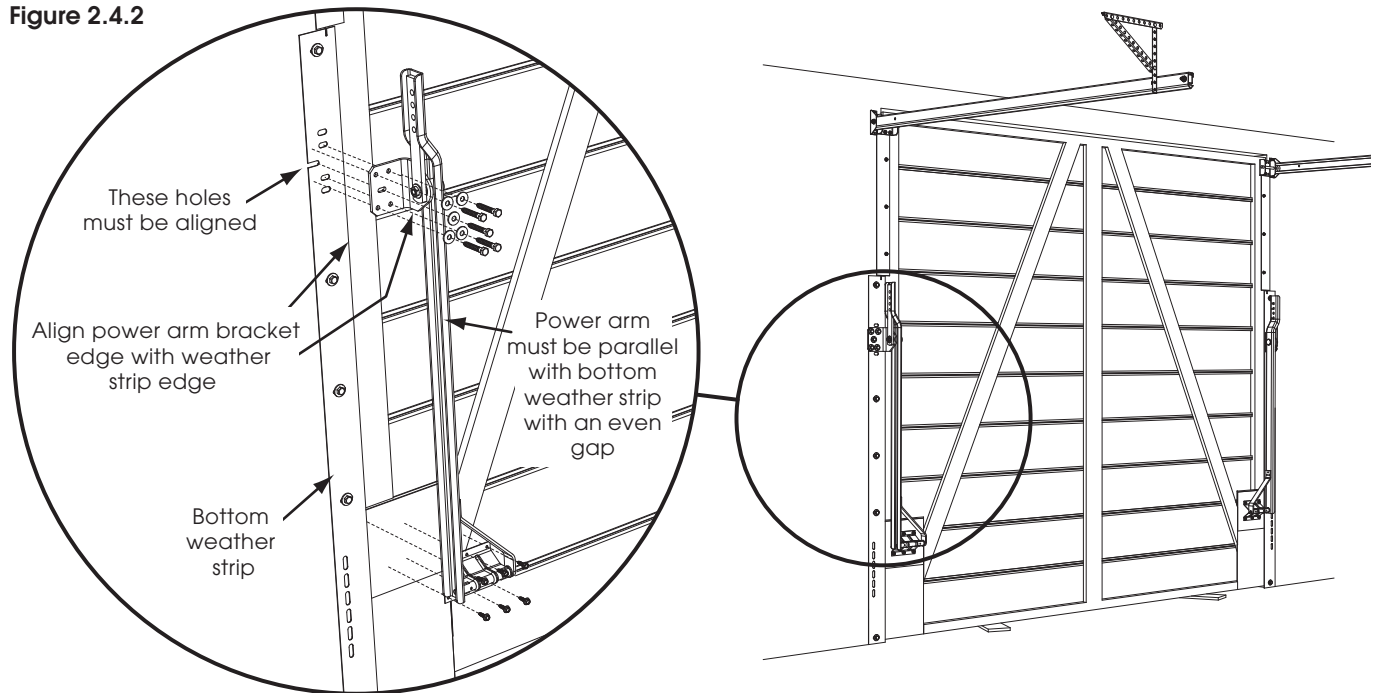

## 2.5 lifting and securing door

Prop up the door as shown in Figure 2.5.1.

Figure 2.5.1

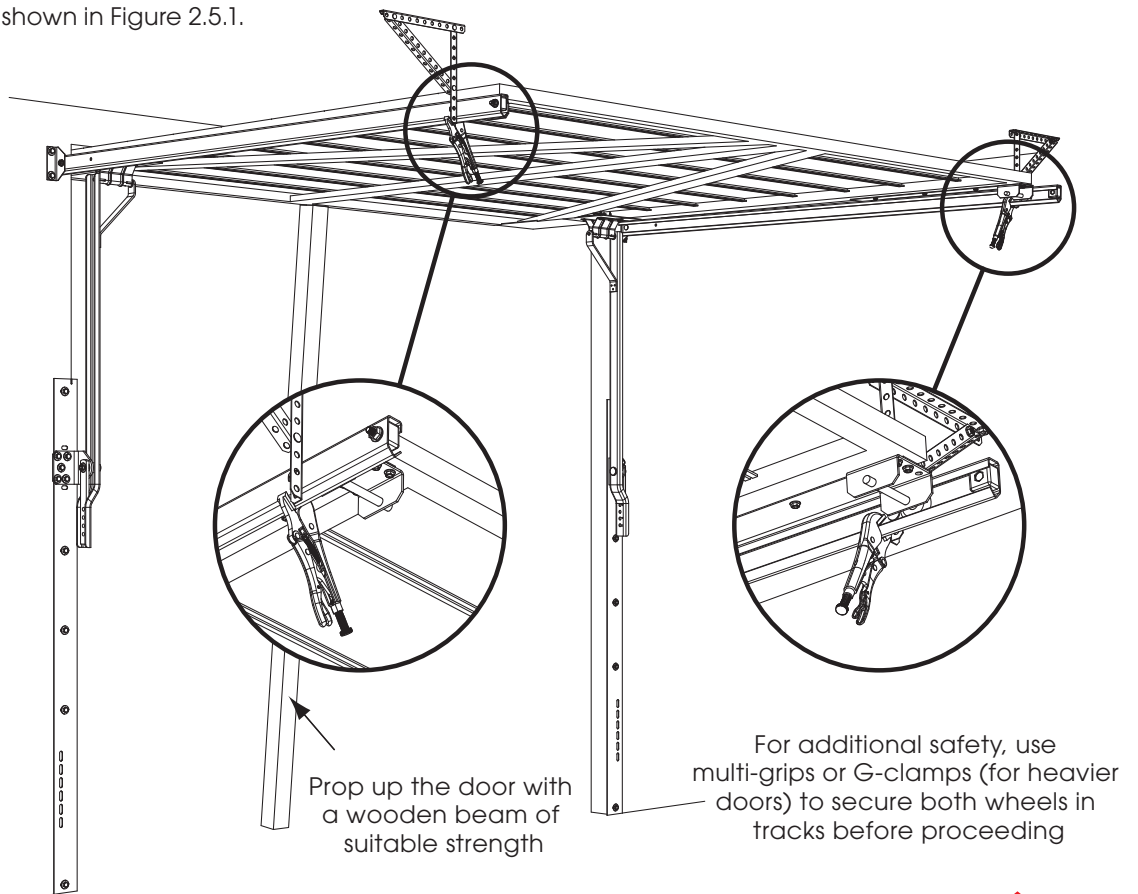

## 2.6 spring assembly

Assemble spring unto the kicker bolt, then mount assembly to the No. 2 hole (there are hole numbers on the power arm for reference). Figure 2.6.1 shows the assembly of a double spring system. Note the clover hook needs to be assembled onto the kicker bolt assembly. Figure 2.6.2 shows the assembly of a single spring system. Note the spring is assembled onto the kicker bolt.

Locate and secure anchor bracket in a position so that the nut can just be screwed on. In this way when the screw is tightened the spring should be stretched to about 50mm.

Figure 2.6.2

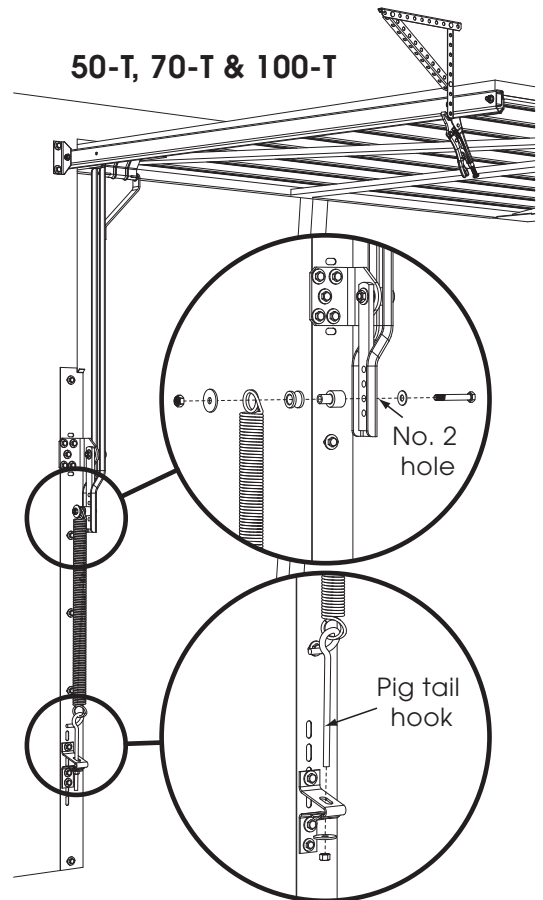
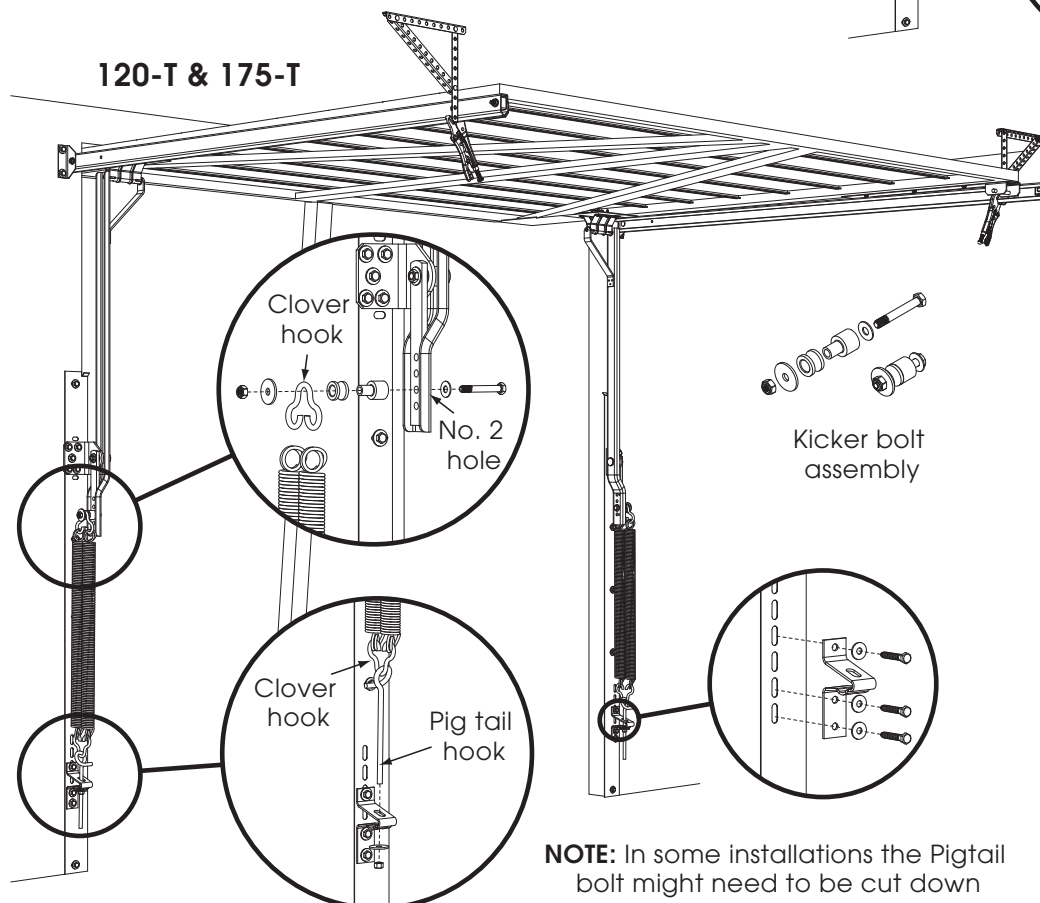

Figure 2.6.1



**NOTE:** In some installations the Pigtail bolt might need to be cut down



## 2.7 final adjustments

Check that the clearance gaps are all even on the open door and that the power arms are square in both the open and closed position using a spirit level, adjust with wedge packers as necessary and perform any final adjustments to the track bracing.

Bend the inside of the tab on the bottom weatherstrip as shown in Figure 2.7.1.A.

### If door comes down too easily

- Increase tension of spring by tightening up the nut on the pigtail bolt or
- Swing door overhead and secure in place (see STEP 2.5 LIFTING AND SECURING DOOR), loosen nut on pigtail bolt to relieve tension on the spring, then move kicker bolt down one hole. **WARNING**, doors must be secured and tension relieved before shifting the kicker bolt.

### If door is hard too pull down

- Reduce tension by loosening the nut on the pigtail bolt or
- Swing door overhead and secure in place (see STEP 2.5 LIFTING AND SECURING DOOR), loosen nut on pigtail bolt to relieve tension on the spring, then move kicker bolt one hole up. **WARNING**, doors must be secured and tension relieved before shifting the kicker bolt.

### If the door rubs against the jamb

- Loosen the fasteners on the power arm bracket (just enough that the bracket can shift only), open door then pivot power arm away from jamb concerned and then retighten fasteners.
- Lift and prop up door as in STEP 2.5 LIFTING AND SECURING DOOR. Recheck that the tracks are square to the opening by measuring diagonal and adjust bracing accordingly as in STEP 2.3 INSTALLING TRACKS.

Figure 2.7.1

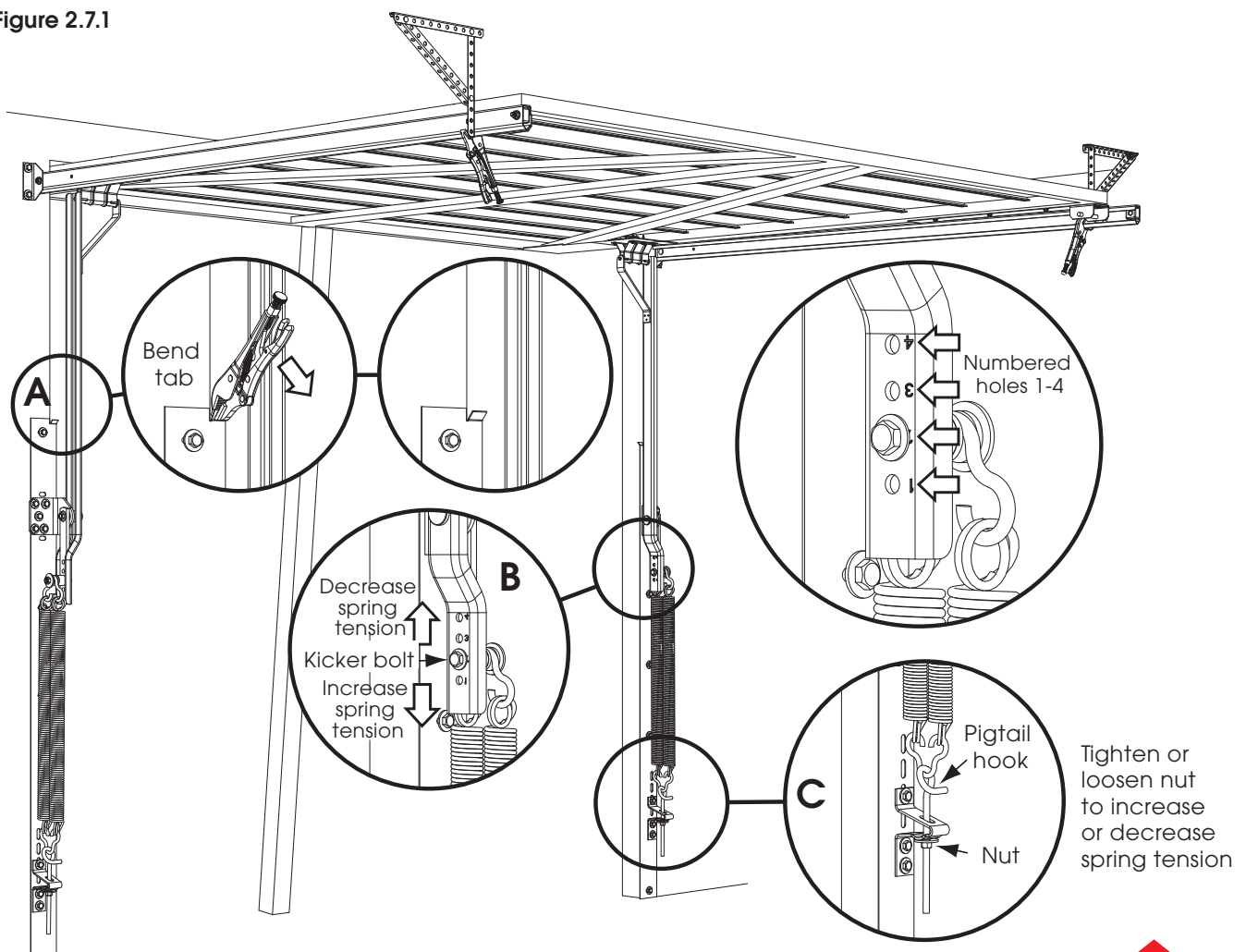

## 3.0 after installation care

### general care of your Tilt-A-Dor® T-Fitting

#### cleaning

It is recommended that your fittings be serviced, by an experienced door technician, every 12 months (more regularly in extreme environments or frequent use), or earlier if required.

#### lubrication

To ensure smoother operation the following areas are to be periodically lubricated to minimise wear and noise.

- The kicker bolt where the clover hook is attached
- The pig tail hook and anchor bracket
- Pivot of the anti-sway arm bracket

#### spring tension

It is natural for springs to lose tension over time. When spring tension is adjusted or when your door is first installed it is usual to apply a little more tension than is required for balanced operation, to allow for the normal "settling in" of the springs.

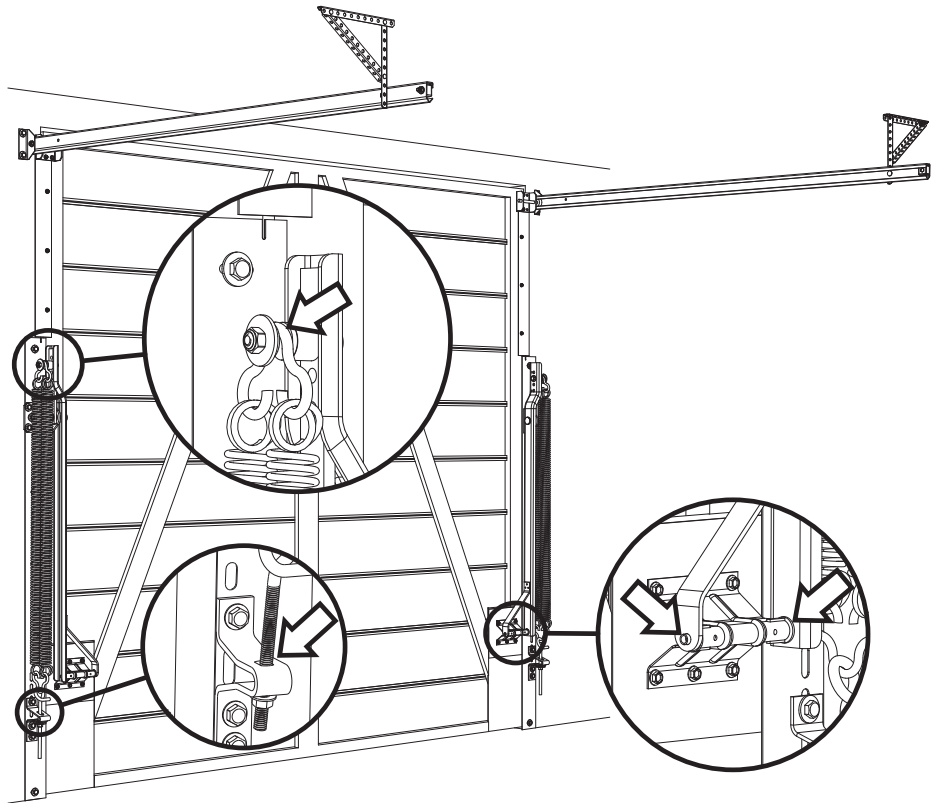

### WARNING!

The spring is under tension at all times and may cause serious injury if interfered with by an inexperienced person. Adjustments and repairs should be carried out by approved B&D dealers using proper tools. Nobody should ever stand directly in the path of the door in its downward travel or walk through doorway while door is moving. Always use the door handle or pull rope to manually operate the door. If the door is automated, the pull down rope on the door must be removed.

**DO NOT PLACE FINGERS, HEAD OR LIMBS NEAR ANY MOVING PARTS OF MECHANISM ON EACH SIDE OF THE DOORWAY WHEN THE DOOR IS OPERATING EITHER AUTOMATICALLY OR MANUALLY.**

#### b&d doors office locations

New South Wales	34 Marigold St, Revesby 2212	Phone (02) 9722 5555
Queensland	17 Oasis Court, Clontarf 4019	Phone (07) 3883 0200
Newcastle	Unit 1/108 Mitchell Rd, Cardiff 2285	Phone (02) 4956 8533
Victoria	147-153 Canterbury Rd, Kilsyth 3137	Phone (03) 9237 7766
South Australia	23 Frederick Rd, Royal Park 5014	Phone (08) 8440 4747
Western Australia	96 Mulgul Rd, Malaga 6090	Phone (08) 9247 8777
International/Export	34 Marigold St, Revesby 2212	Phone +61 (0)2 9722 5555

your representative is

Prefixed trademarks are the property of B&D Australia Pty Ltd. B&D Doors & Openers is a division of B&D Australia Pty Ltd. ABN 25 010 473 971. © 2016 B&D Australia Pty Ltd.

[www.bnd.com.au](http://www.bnd.com.au)

**b&d**