



# Auto-Lock Kit

For B&D Roll-A-Door® R1N.

## Auto-Lock Contents

GARAGE DOOR LOCK - ORDER NO. 87835		
ITEM	DESCRIPTION	QTY
1	GARAGE DOOR LOCK	2
2	BUTTON HEAD SCREW ZN M6 X 10	4
3	TAPTITE "P" BLACK SCREW M3 X 14	8
4	BATTERY C-LR14	4
5	WIRELESS BASESTATION MODULE	1
6	VELCRO	1



**WARNING!** This lock has been designed to work with B&D Roll-A-Door Neo garage doors.

If you fit this lock to other branded garage door, we cannot guarantee the performance of the lock and any performance warranties will not apply. This is subject to any Statutory Guarantees that may apply. Please refer to our warranty terms and conditions set out in the B&D Owners Opener Handbook.



This device will slide a bolt into the guide track automatically when the door is closed. **DO NOT** install in garages that have only one exit.

For emergency lock / unlock press the lock / unlock button on the Auto-Lock. This will disengage the lock from the guide track and allow you to disengage the opener and open the door. The lock will automatically re-engage after the next complete cycle.



**CAUTION:** Ensure bolt on Auto-lock is free to move during limit setup.

## Important Safety Instructions



### WARNING!

- DO NOT attempt to disassemble, repair or modify the product. This will invalidate the warranty.
- DO NOT allow children to play with the Auto-Lock.
- DO NOT install in garages that have only one exit.
- DO NOT cover, paint or lubricate the product.



### CAUTION:

Burns

- DO NOT handle damaged or leaking batteries
- The Auto-Lock Kit contains sealed lead-acid batteries that must be disposed of properly at the end of their useful life.

Muscle strain

- DO NOT attempt to lift the door manually when the Auto-lock is engaged.

## Bracket Kit (Kit sold separately)

STANDARD BRACKET KIT - ORDER #MC0124		
ITEM	DESCRIPTION:	QTY
8	WALL BRACKET	2
9	CORRUGATED PLATE	1
10	ALCOHOL WIPES	2
12	BRACING BAR ANGLE STEEL CLIPS	2
PLUS PACKAGED SEPARATELY		
13	BRACING BAR	1

LIMITED SIDEROOM BRACKET KIT - ORDER #MC0114		
ITEM	DESCRIPTION:	QTY
7	CURTAIN STRIKER LHS & RHS	2
8	WALL BRACKET	2
9	CORRUGATED PLATE	1
10	ALCOHOL WIPES	2
11	60mm HEAD STOP	1
12	BRACING BAR ANGLE STEEL CLIPS	2
PLUS PACKAGED SEPARATELY		
13	BRACING BAR	1



**WARNING!** Ensure the opener is not engaged when the Auto-lock is being used with only the bolt unit. Failure to do so may void the warranty of the opener.

**Auto-Lock compatible with RDO-1V4 openers with firmware #59**



It is our strong recommendation that your opener be fitted with **SAFETY BEAMS**.

Safety Beams detect any obstructions in the door/gate's path and override automatic operation if one presents. These must be installed as in accordance with AS/NZS 60335-2-95:2012.



## prior to installation

### Preparation - setting the door limits

Ensure the door limits have been set on the opener, prior to installing the Auto-lock. Refer to the opener manual for instructions.

**WARNING!** remove all manual locking systems prior to installing lock. Any damage as a result of a manual lock will void the warranty for the door, Auto-lock and opener.

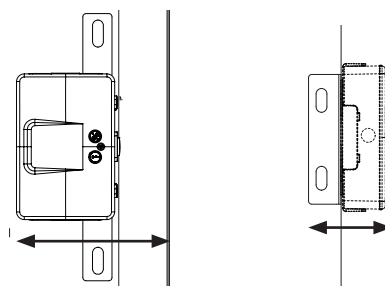

MINIMUM SIDEROOM REQUIRED FROM INSIDE GUIDE TO EDGE OF BRACKET/AUTO-LOCK		
INSTALLATION	STANDARD (side mount)	LIMITED SIDE ROOM (front mount)
R1N	135mm	90mm

### install batteries

- Insert batteries (4) into drive unit.
- Place cover back on drive unit and secure with 4 x screws (3).

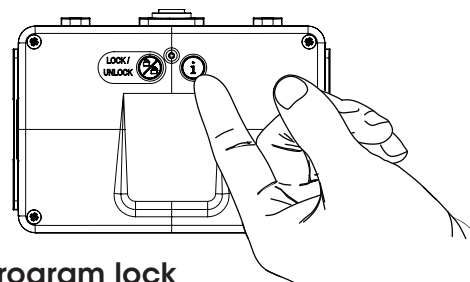
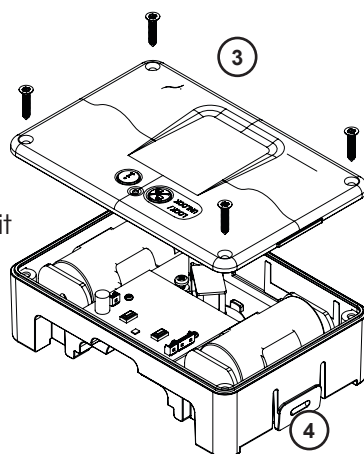

### program lock

- Press and hold the info button (i) on drive unit until the light goes red.
- Then press the lock/unlock button to test the drive unit.

## install striker & corrugated plate

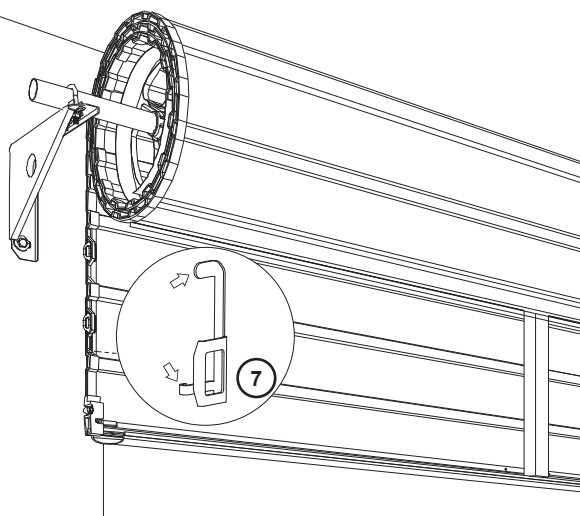

### Limited Sideroom installs (only)

- Before the guides are installed on the door, place the lock striker (7) into the second bottom curtain corrugation, pushing striker towards the door edge, whilst sliding the legs under the Nylofelt® and hooking them over the curtain edge, before snapping into position as per diagram.
- Repeat for second lock striker at other side of door.
- Continue with door installation before proceeding.

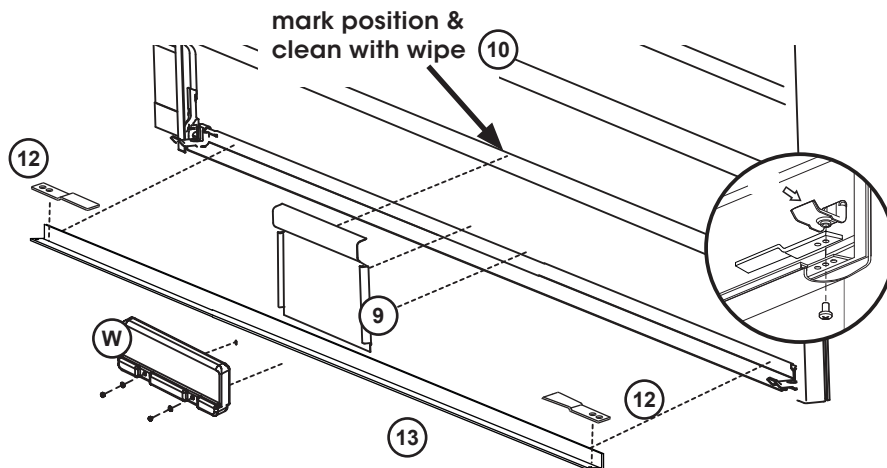

### Install Corrugated plate

- Unscrew the bottom rail stop on each side of the door.
- Cut the bracing bar (13) to the length of bottom rail and pre-drill hole at each end for bottom rail stop.
- Fit angle steel clips (12) at each end, before refitting bottom rail stop.
- Measure the middle point of the door at the first corrugation. Place corrugated plate (9) at middle point and mark position of edges on door.
- Use Alcohol wipe (10) to clean surface where plate is to be fitted.
- Remove tape from corrugated plate and place on door.
- Take the weight bar (W), nuts and screws from the opener box and install as shown.

### standard installation for Roll-A-Door Neo (side mount)

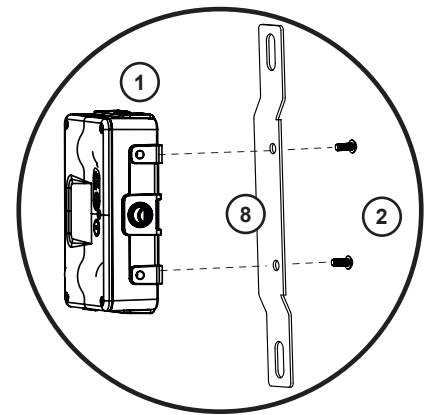
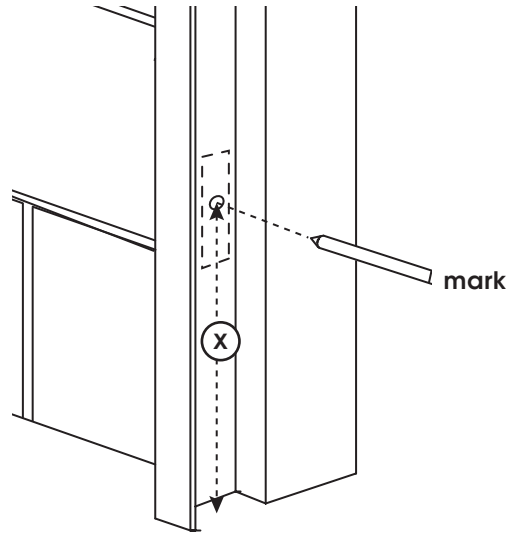
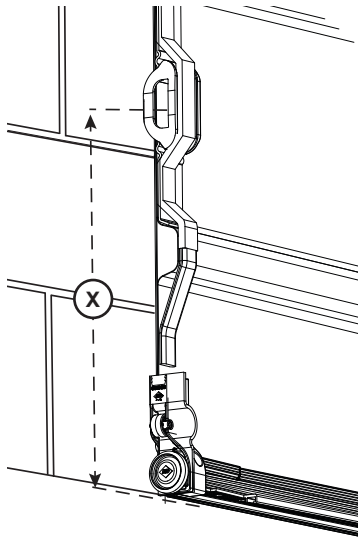

- a. After limits are set on the opener, measure the position (X) of each lock striker from the ground to the middle of the lock striker as shown.
- b. Open the door, place some tape inside each guide and transfer measure (X) to middle of guide.
- c. Using an 18mm stepped drill, drill a hole through the guide and remove any burs from hole.
- d. Assemble both AutoLocks (1) to the wall brackets (8) using 2 x button head screws (2), ensuring the flat side of the lock bolt is facing the door.

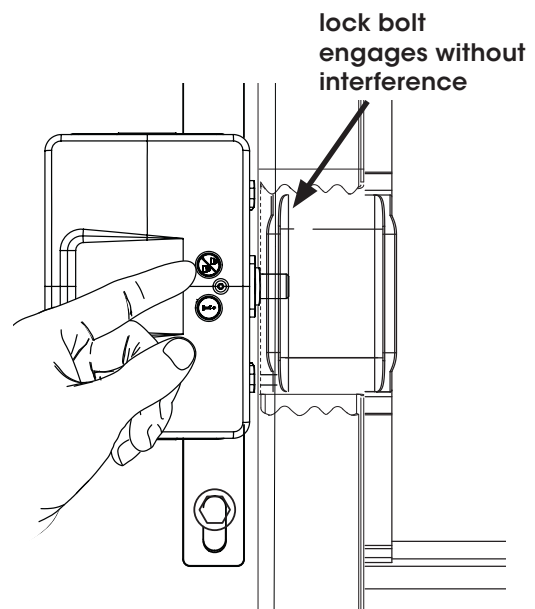
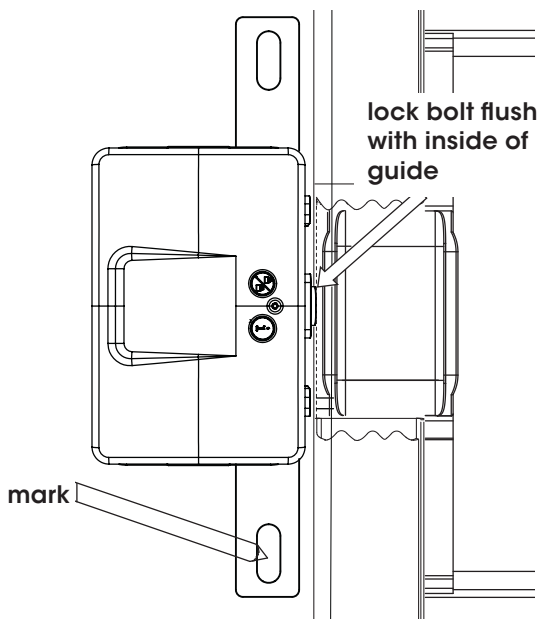

- e. Place bracket on wall up against the guide and ensure the body of the lock bolt is flush with the inside of the guide.
- f. Mark the position of the bracket holes on the wall. Pre-drill holes and affix to wall with 2 x coach screws and washers. (not supplied)
- g. With the door closed, test the operation of each AutoLock by pressing the lock/unlock button to ensure the lock bolt fully engages through the guide and into the striker without interference.

**PROCEED TO CONNECTING WIRELESS BASE STATION TO THE OPENER.**



### limited side room installation for Roll-A-Door Neo (front mount)

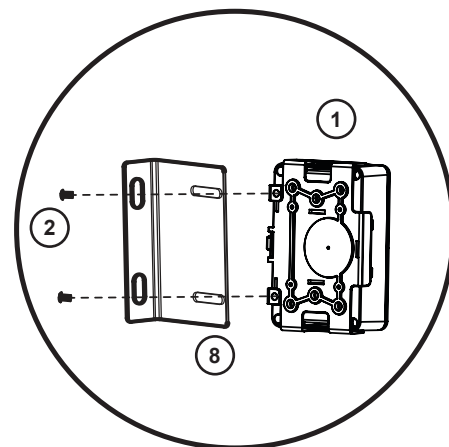
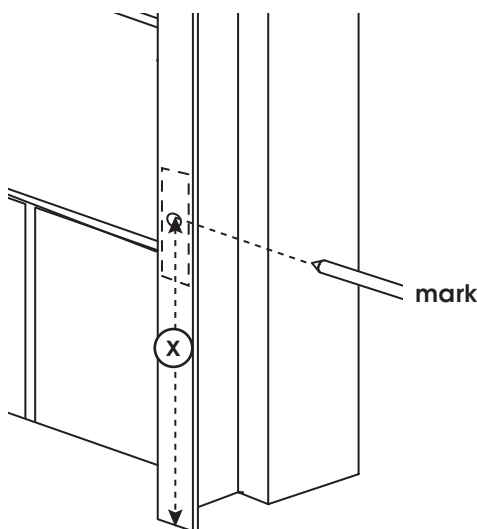
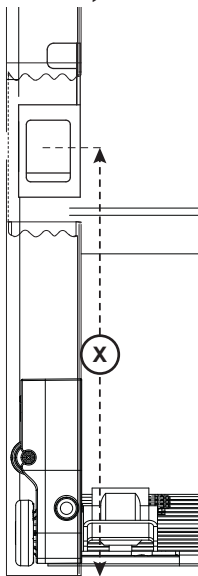

- a. After limits are set on the opener, measure the position (X) of each lock striker from the ground to the middle of the lock striker. (as shown).
- b. Once both lock strikers are installed, test manual operation of the door to ensure no sticking or scraping within the guide.

- c. Open the door, place some tape inside each guide and transfer measure (X) to middle of guide.
- d. Using an 18mm stepped drill, drill a hole through the guide and remove any burrs from hole.

- e. Assemble both AutoLocks (1) to the wall brackets (8) using 2 x button head screws (2), ensuring the flat side of the lock bolt is facing the door.

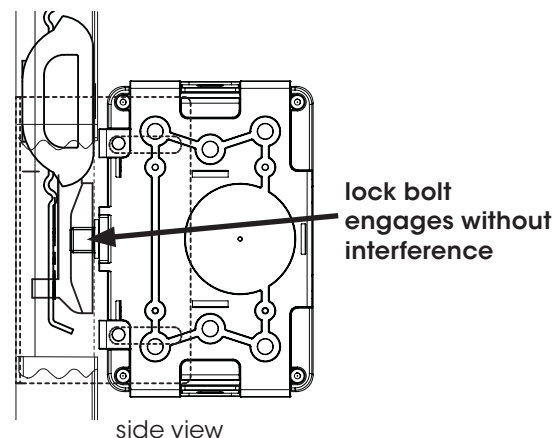
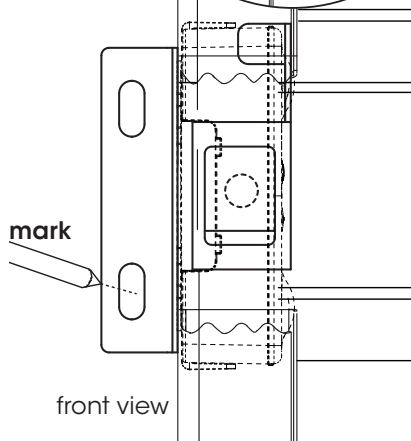
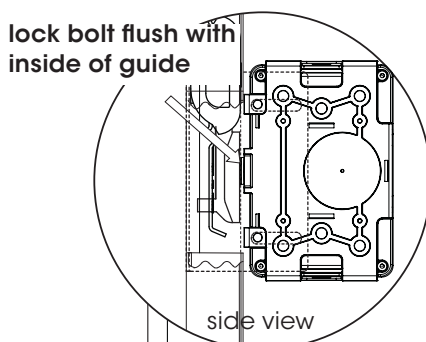
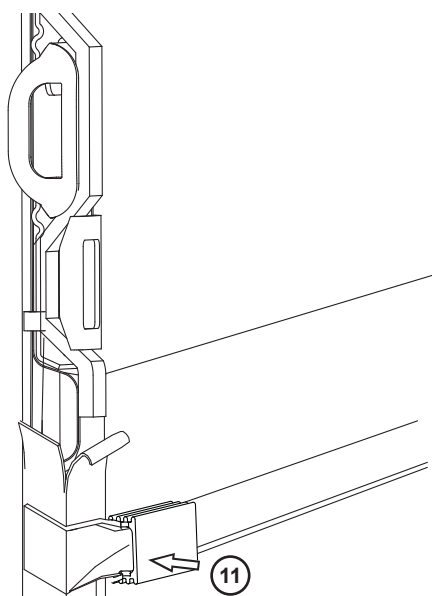

- f. Remove the old head stop and replace with longer head stop (11).
- g. Unscrew the bottom rail stop on each side of the door and move into the inner hole and refit screw as shown.

- h. Place bracket on wall up against the guide and ensure the body of the lock bolt is flush with the inside of the guide.
- i. Mark the position of the bracket holes on the wall. Predrill holes and affix to wall with 2 x coach screws and washers. (not supplied)

- j. With the door closed, test the operation of each AutoLock by pressing the lock/unlock button to ensure the lock bolt fully engages through the guide and into the striker without interference.

**PROCEED TO CONNECTING WIRELESS BASE STATION TO THE OPENER.**

## connect basestation to opener

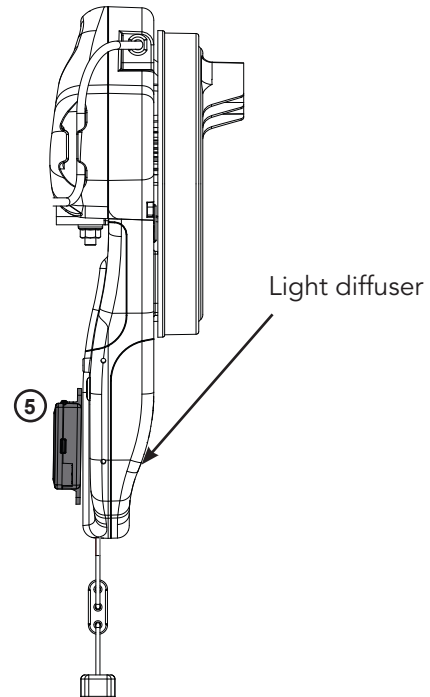
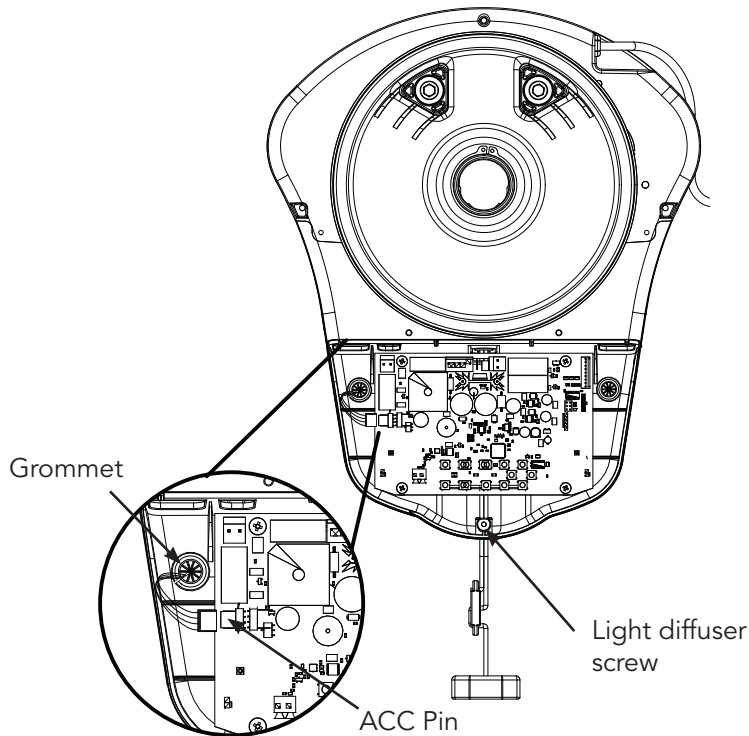

- Disconnect the power supply to the opener.
- Remove the light diffuser via screw at the bottom.
- Remove the grommet out of the back cover.
- Cut (1) one side of the grommet with a knife or scissors.
- Connect harness to basestation (5), before sliding into the cut in the grommet.
- Refit grommet to back cover by inserting the harness through hole before fitting grommet.

- Place the velcro (6) onto the basestation (5) and secure to the back of the opener as shown.
- Connect the harness to the ACC 4 pin on the control board.
- Refit the light diffuser.
- Reconnect power to the opener and test operation via the opener.
- Upon completion of a full cycle the lock will engage into the track.



**tip** If a PE Beam is installed ensure that the channels on the basestation on each device are different. The channel on the basestation can be changed by sliding the switch in either direction.

## emergency operation

Press the emergency lock/unlock button on the front of each Auto-Lock to disengage the locking bolt from the guide track and allow you to disengage the opener and open the door.



**WARNING!** The emergency lock/unlock button on this product is not to be used as a primary means of locking the door under normal circumstances.

The emergency lock/unlock button is to be used only in case of power outage or emergency.

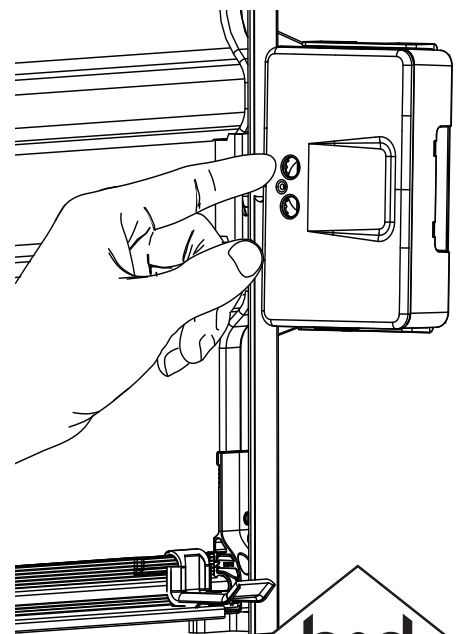

## led status

### lock position status

The status normally displays for 10secs after lock movement / button press.

LED STATUS INDICATORS		
RED	GREEN	LOCK STATUS
FLASHING RAPIDLY		LOCKING
ON		LOCKED
	FLASHING RAPIDLY	UNLOCKING
	ON	UNLOCKED
ON	ON	ERROR
FLASHING SLOWLY	FLASHING SLOWLY	LOW BATTERY
FLASHING ALTERNATIVELY	FLASHING ALTERNATIVELY	NO LINK WITH BASESTATION

## troubleshooting

Symptom	Possible cause	Remedy
door not moving and no lights on lock	limited battery power	press the (i) button on the lock to see if there is power in the battery. no lights - change battery lights - check LED status table.
lock is not unlocking and preventing doors movement	lock jammed	ensure the lock bracket is square to the guide (if not use packers). Check if there is anything obstructing the lock bolt movement. Press the unlock button on each lock. If it does not move call 13 62 63.
red and green lights both on solid on the lock.	error with lock	press the unlock button on the lock to test operation. switch off power to opener, then switch back on after 30 secs (If a battery backup is installed press & hold STOP/SET button on the opener until power ceases). Press the lock/ unlock button on the lock to test operation. If it does not move call 13 62 63.
one lock has lights the other lock has no lights	limited battery power	press the (i) button on the lock without lights to see if there is power in the battery. no lights - change battery lights - check LED status table.
red and green lights on one lock flashing slowly	low battery	change battery, then test operation of lock by pressing the lock / unlock button.
red and green lights flashing alternatively	no link to opener	Disconnect power to the opener and check connection of the basestation harness to the control board.

## battery change

- Replace lock batteries (2 x C-LR 14) immediately when the Auto-lock LED's red and green lights flash 3 times or are flashing slowly.
- Remove cover by unscrewing the four screws on the main cover.
- Replace batteries, refit cover and secure with screws.
- Operate opener to complete a full open / close cycle and ensure Auto-lock engages.

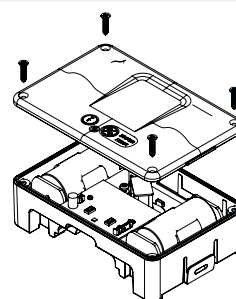

Remove screws to open main cover

WARRANTY	
ACCESSORIES	1 year

Refer to our website for full warranty details:  
[www.bnd.com.au/repairs-service/door-warranty](http://www.bnd.com.au/repairs-service/door-warranty)

If you are a consumer under the Australian Consumer Law, our goods come with guarantees that cannot be excluded under the Australian Consumer Law. You are entitled to a replacement or refund for a major failure and for compensation for any other reasonably foreseeable loss or damage. You are also entitled to have the goods repaired or replaced if the goods fail to be of acceptable quality and the failure does not amount to a major failure. This warranty certificate and other statements contained in this document or other B&D documents given to you do not exclude, restrict or modify the application of all or any of the provisions of the Australian Consumer Law. Subject to your non-excludable rights under the Australian Consumer Law, B&D expressly excludes any liability for consequential loss, incidental or indirect damages (including but not limited to damages for loss of business profits, business interruption and loss of business information) due to a defect of the Product. In particular, any loss or damage caused to other equipment or accessories used with the product or any loss resulting from a delay in repair is excluded to the extent permitted by law.

## b&d group office locations

<b>Head Office</b>	6-8 Fiveways Blvd, Keysborough 3173	Phone (03) 9791 0200
<b>New South Wales</b>	34 Marigold St, Revesby 2212	Phone (02) 9722 5555
<b>Queensland</b>	17 Oasis Court, Clontarf 4019	Phone (07) 3883 0200
<b>Victoria</b>	147-153 Canterbury Rd, Kilsyth 3137	Phone (03) 9237 7766
<b>South Australia</b>	23 Frederick Rd, Royal Park 5014	Phone (08) 8440 4747
<b>Western Australia</b>	96 Mulgul Rd, Malaga 6090	Phone (08) 9247 8777
<b>International/Export</b>	34 Marigold St, Revesby 2212	Phone +61 (0)2 9722 5555
<b>New Zealand</b>	46 Braeburn Dr, Hornby, Chch 8082	Phone +64 (0)3 384 5145

your representative is

Prefixed trademarks are the property of B&D Australia Pty Ltd. B&D Doors & Openers is a division of B&D Australia Pty Ltd. ABN 25 010 473 971. © 2016 B&D Australia Pty Ltd.

[www.bnd.com.au](http://www.bnd.com.au)