

DESIGN CRITERIA:

(REFER ALSO TO NOTES COVERING BASIS OF DRAWINGS & LIMITATIONS)
 DOOR HEIGHT (RC1-3) = 2.64m MAX.
 DOOR HEIGHT (RD1-5) = 2.4m MAX.
 WIND RATING C2 (FOR RC1-3) AND C4 (FOR RD1-5) AS GIVEN IN TABLE 5.2 OF AS/NZS 4505:2012 OR APPROXIMATELY EQUAL TO THE FOLLOWING WIND RATING WHEN IN ACCORDANCE WITH AS/NZS 1170.2:2021.

FOR RC1-3 CONFIGURATIONS

- REGION C
- TERRAIN CATEGORY 2
- INTERNAL PRESSURE COEFFICIENTS CPI = (-0.4,+0.55)
- REGIONAL WIND SPEED $V_r = 66\text{m/s}$

FOR RD1-5 CONFIGURATIONS

- REGION D
- TERRAIN CATEGORY 1
- INTERNAL PRESSURE COEFFICIENTS CPI = (-0.65,+0.8)
- REGIONAL WIND SPEED $V_r = 80\text{m/s}$

THE MAXIMUM DESIGN WIND PRESSURES ARE NOT TO EXCEED THE FOLLOWING MAGNITUDES:

FOR RC1-3 CONFIGURATIONS

1. FOR DOORS WIDTHS LESS THAN 4m
 - ULTIMATE DESIGN INWARD WIND PRESSURE = 2.92KPa.
 - ULTIMATE DESIGN OUTWARD WIND PRESSURE = 3.37KPa.
2. FOR DOORS WIDTHS GREATER THAN 4m
 - ULTIMATE DESIGN INWARD WIND PRESSURE = 2.92KPa.
 - ULTIMATE DESIGN OUTWARD WIND PRESSURE = 3.04KPa.

DESIGN CRITERIA (continued):

FOR RD1-5 CONFIGURATIONS

1. FOR DOOR WIDTHS LESS THAN 4m
 - ULTIMATE DESIGN INWARD WIND PRESSURE = 5.81KPa.
 - ULTIMATE DESIGN OUTWARD WIND PRESSURE = 6.69KPa.
2. FOR DOOR WIDTHS GREATER THAN 4m
 - ULTIMATE DESIGN INWARD WIND PRESSURE = 5.81KPa.
 - ULTIMATE DESIGN OUTWARD WIND PRESSURE = 6.04KPa.

LIMITATIONS:

- STEEL ABUTMENT POST AND STEEL LINTEL TO BE 2.4mm (MIN.) AND 3.0mm (MIN.) THICK RESPECTIVELY, WITH A MINIMUM STRESS GRADE OF 250 MPa U.N.O.
- CHARACTERISTIC UNCONFINED COMPRESSIVE STRENGTH OF BLOCK WALL UNIT (f_{uc}) = 15 MPa (MIN.)
- CORE FILLING OF BLOCKWALL (f_c) = 15 MPa (MIN.).
- CONCRETE STRENGTH OF SLAB FOR BASE FLOOR FLANGE FIXING (f_c) = 20 MPa.
- ALL DOOR COMPONENTS TO BE IN ACCORDANCE WITH STANDARD B&D WINDPANEL™ MANUFACTURING.
- DOOR INSTALLATION TO BE IN ACCORDANCE WITH STANDARD B&D WINDPANEL™ INSTALLATION GUIDELINES.
- WINDPANEL™ BRACES TO BE INSTALLED WHEN CYCLONE WARNING IS ISSUED.
- WINDPANEL™ BRACES ARE TO BE INSTALLED AND MAINTAINED IN ACCORDANCE WITH MANUFACTURERS INSTALLATION GUIDELINES AND HANDLING PROCEDURES.

LIMITATIONS (continued):

- THE STRUCTURE TO WHICH THE DOOR IS ATTACHED, INCLUDING LINTEL HEADS CEILING WIND BEAMS AND SUPPORT ABUTMENTS SHALL BE ASSESSED AND CERTIFIED INDEPENDENTLY AS REQUIRED BY A SUITABLY QUALIFIED ENGINEER.
- ALTERNATIVE DESIGN PARAMETERS TO WHAT ARE SPECIFIED ON THESE DRAWINGS ALONG WITH ALTERNATIVE SITE SPECIFIC LOCAL PRESSURE FACTORS MAY BE ADOPTED PROVIDED THE CALCULATED SITE SPECIFIC ULTIMATE DESIGN WIND PRESSURES DO NOT EXCEED THE ULTIMATE DESIGN WIND PRESSURE RATINGS SPECIFIED IN THE DESIGN CRITERIA.
- THE BUILDING DESIGN ENGINEER IS TO ENSURE THAT THE SITE SPECIFIC DESIGN WIND LOADINGS DO NOT EXCEED THE ULTIMATE DESIGN WIND PRESSURE RATINGS AS SPECIFIED IN THE DESIGN CRITERIA.
- DOORS MAY BE POSITIONED AT ANY LOCATION ALONG THE BUILDING ENVELOPE INCLUDING ALL LOCAL PRESSURE ZONES (ie. CORNERS OF BUILDINGS), PROVIDED THE CALCULATED SITE SPECIFIC ULTIMATE DESIGN WIND PRESSURES DO NOT EXCEED THE ULTIMATE DESIGN WIND PRESSURE RATINGS SPECIFIED IN THE DESIGN CRITERIA.

LIMITATIONS (continued):

- NOTES COVERING BASIS OF DRAWINGS (RELEVANT TEST REPORTS etc)
- REPORT No's TS917 & TS811 Revision A (CYCLONE TESTING STATION, SCHOOL OF ENGINEERING AND PHYSICAL SCIENCES, JAMES COOK UNIVERSITY).
- PRINCIPLES OF MECHANICS.
- AS/NZS 1170.2:2021-STRUCTURAL DESIGN ACTIONS, PART 2: WIND ACTIONS.
- AS/NZS 1170.1:2002-STRUCTURAL DESIGN ACTIONS, PART 1: PERMANENT, IMPOSED AND OTHER ACTIONS.
- AS/NZS 1170.0:2002-STRUCTURAL DESIGN ACTIONS, PART 0: GENERAL PRINCIPLES.
- AS 4100:2020-STEEL STRUCTURES.
- AS 1720.1:2010-TIMBER STRUCTURES, PART 1: DESIGN METHODS.
- AS/NZS 4600:2018-COLD FORMED STEEL STRUCTURES.
- AS/NZS 3700:2018-MASONRY STRUCTURES
- AS/NZS 1664.1:1997-ALUMINIUM STRUCTURES, PART 1: LIMIT STATE DESIGN.
- AS/NZS 4505:2012 GARAGE DOORS AND OTHER LARGE ACCESS DOORS.
- AS 3600:2018 CONCRETE STRUCTURES.
- AS 4055:2021 WIND LOADS FOR HOUSING.
- BUILDEX FASTENERS-TECHICAL SPECIFICATION.
- RAMSET-SPECIFIERS RESOURCE BOOK.
- REFER TO DESIGN CRITERIA & LIMITATIONS.

ISSUE	DATE	AMENDMENTS
H	09.12.13	GENERAL REVISION
I	21.05.14	GENERAL REVISION
J	16.06.14	GENERAL REVISION
K	18.10.21	GENERAL REVISION
L	22.04.23	GENERAL REVISION

CLIENT	B&D AUSTRALIA PTY LTD
PROJECT	B&D WINDPANEL™ REINFORCED SECTIONAL DOORS WITH VERTICAL BRACES & TRACKLOCK

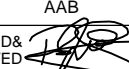
 <p>JAMES ELLIS & ASSOCIATES PTY LTD Consulting Structural Engineers</p> <p>www.jamesellisengineers.com.au PO Box 251, Padstow NSW 2211 Ph: 8764 1035</p>	DRAWING NOTES	SCALE
		DESIGNED J.E.
		DRAWN AAB
		CHECKED & APPROVED  DATE Apr 2023

DRAWING No.	S00 L
PROJECT No.	2191

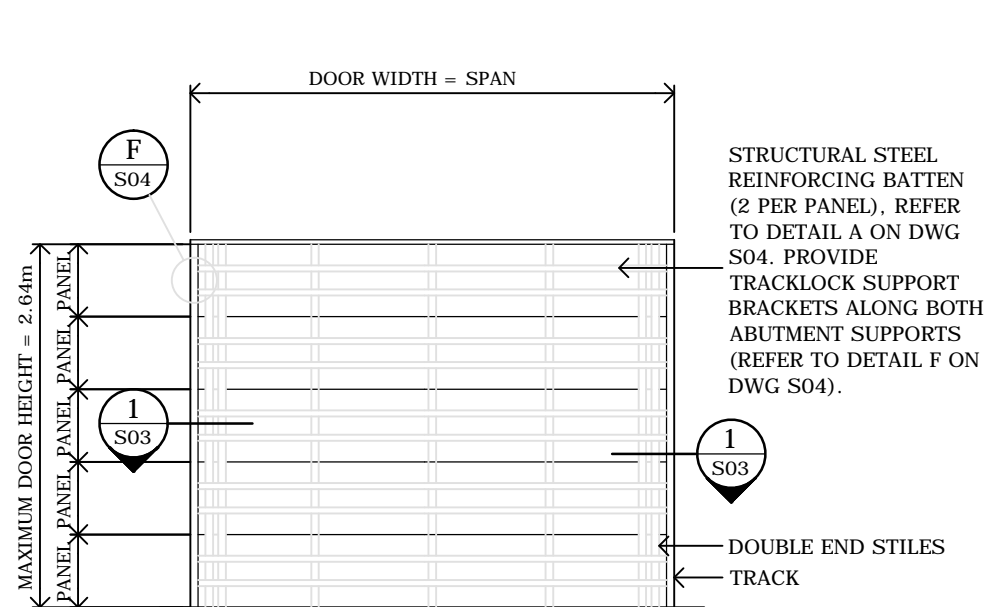

**RC1 ELEVATION - B&D WINDPANEL
TRACKLOCK DOOR UP TO 3.1m DOOR WIDTH**

1:50

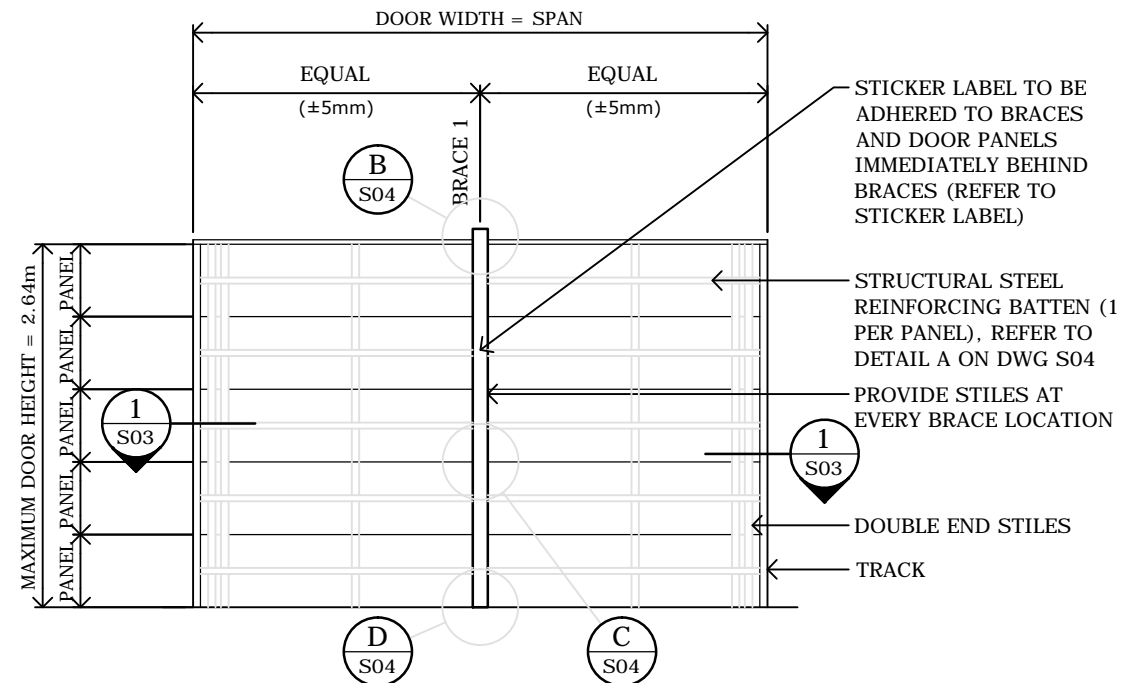

**RC2 ELEVATION - B&D WINDPANEL™ DOOR
3.105m TO 3.7m DOOR WIDTH (ONE BRACE)**

1:50

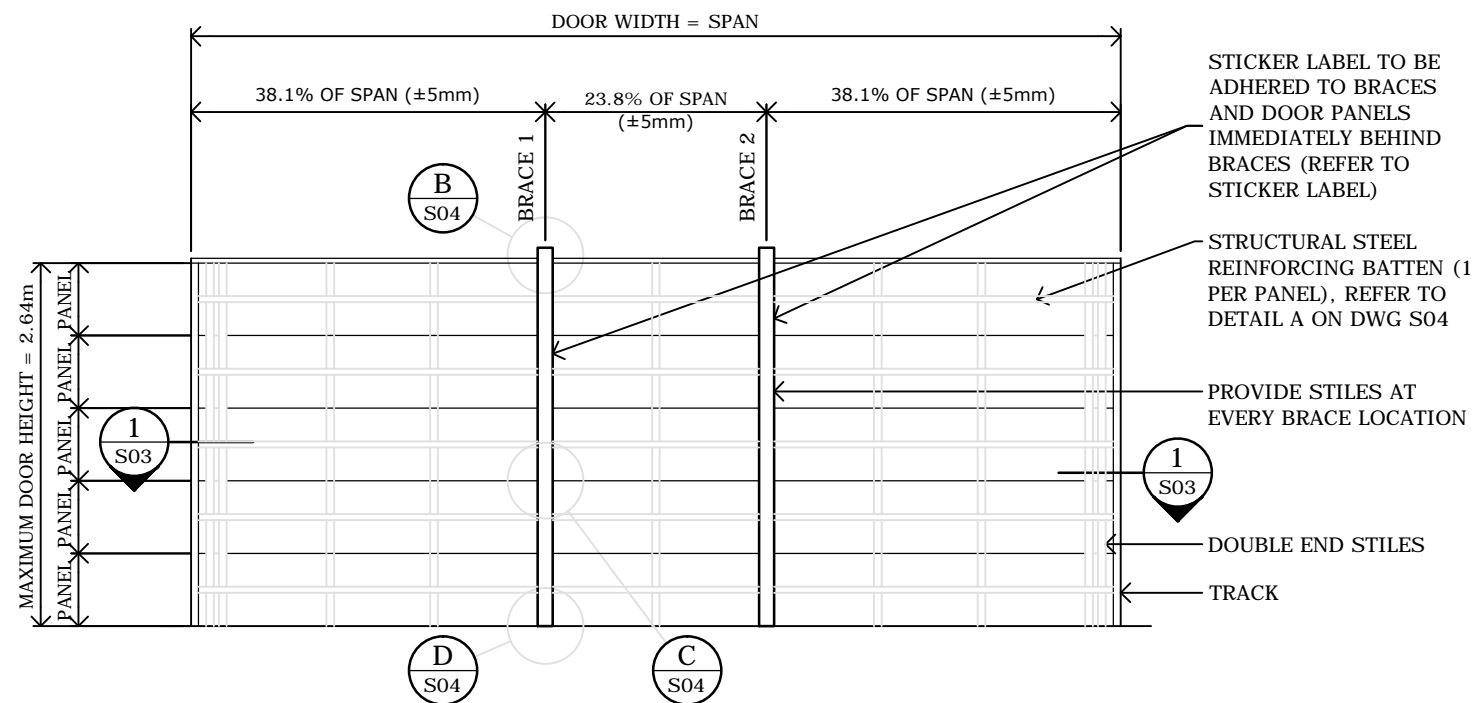

**RC3 ELEVATION - B&D WINDPANEL™ DOOR
3.705m TO 6.15m DOOR WIDTH (TWO BRACES)**

1:50

STICKER LABEL TO BE INSTALLED ON ALL BRACED DOORS:

WARNING:
WINDPANEL™ BRACES ARE TO BE INSTALLED WHEN CYCLONE WARNING IS ISSUED. WINDPANEL™ BRACES ARE TO BE INSTALLED AND MAINTAINED IN ACCORDANCE WITH B&D DOORS AND OPENERS QUICK REFERENCE GUIDE.

RC1 - REGION C, CONFIGURATION 1
RC2 - REGION C, CONFIGURATION 2
RC3 - REGION C, CONFIGURATION 3

ISSUE	DATE	AMENDMENTS
H	09.12.13	GENERAL REVISION
I	21.05.14	GENERAL REVISION
J	16.06.14	GENERAL REVISION
K	18.10.21	GENERAL REVISION
L	22.04.23	GENERAL REVISION

CLIENT	B&D AUSTRALIA PTY LTD
PROJECT	B&D WINDPANEL™ REINFORCED SECTIONAL DOORS WITH VERTICAL BRACES & TRACKLOCK

DRAWING	SECTIONAL DOOR ELEVATIONS FOR USE IN WIND REGIONS C2	
	 JAMES ELLIS & ASSOCIATES PTY LTD Consulting Structural Engineers	
www.jamesellisengineers.com.au PO Box 251, Padstow NSW 2211 Ph: 8764 1035		SCALE DESIGNED J.E. DRAWN AAB CHECKED & APPROVED  DATE Apr 2023

DRAWING No.	S01L
PROJECT No.	2191

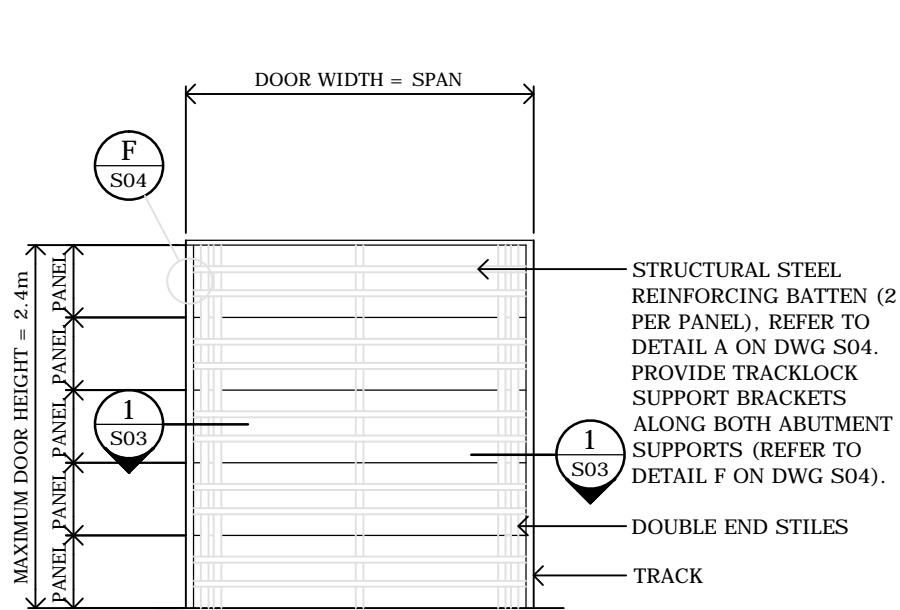

RD1 ELEVATION - B&D WINDPANEL TRACKLOCK DOOR UP TO 2.2m DOOR WIDTH
1:50

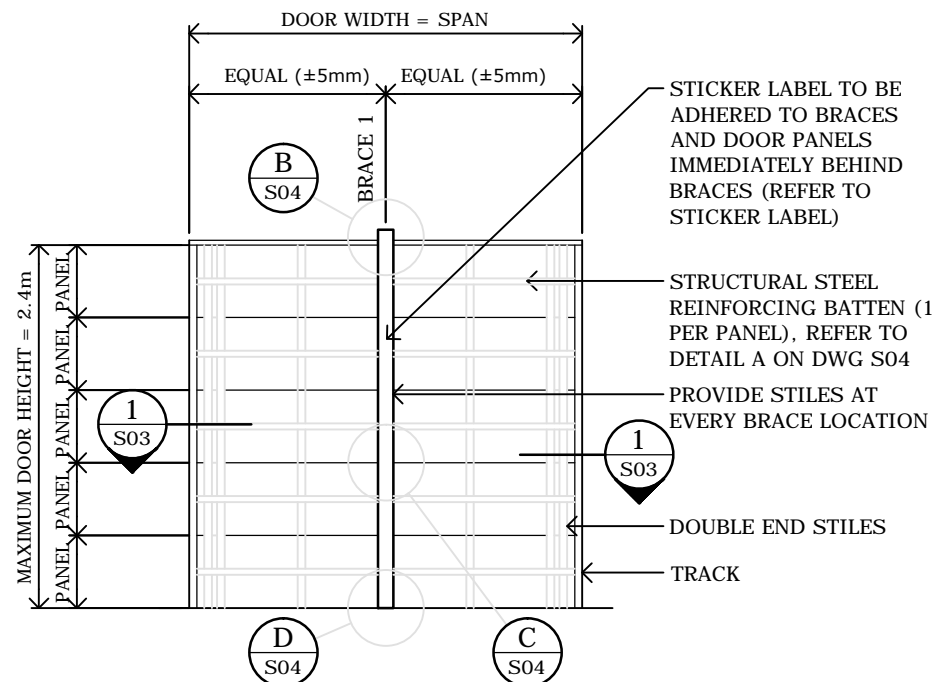

RD2 ELEVATION - B&D WINDPANEL™ DOOR 2.205m TO 2.6m DOOR WIDTH (ONE BRACE)
1:50

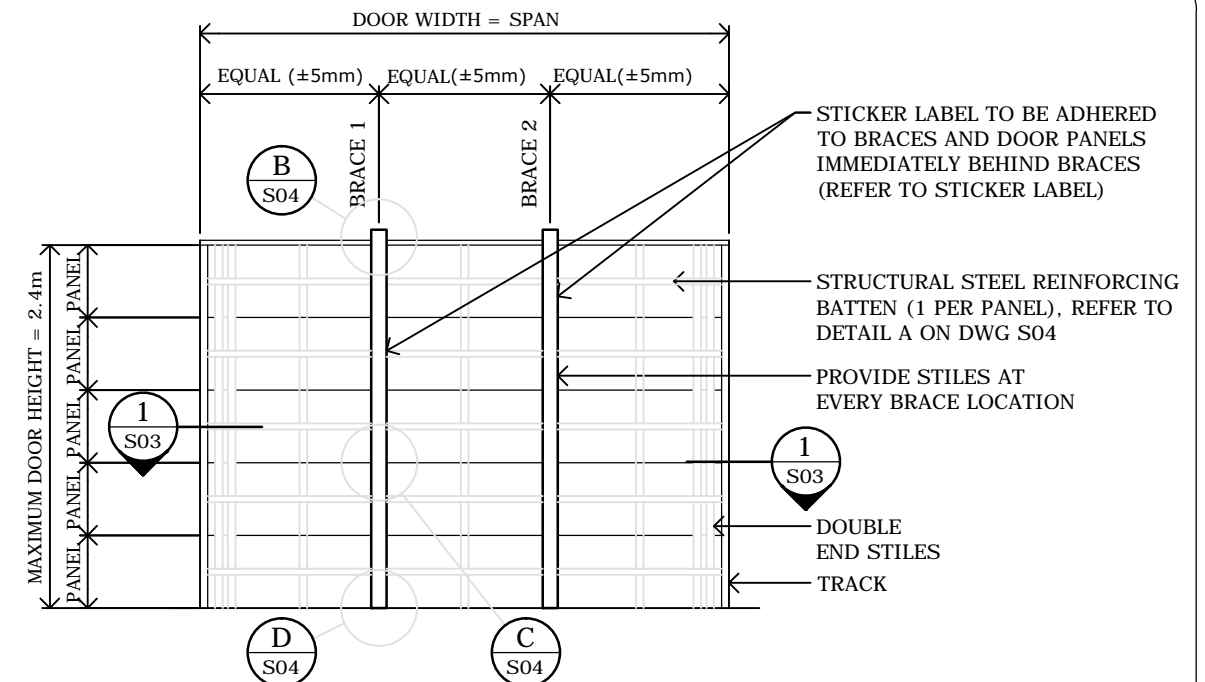

RD3 ELEVATION - B&D WINDPANEL™ DOOR 2.605m TO 3.4m DOOR WIDTH (TWO BRACES)
1:50

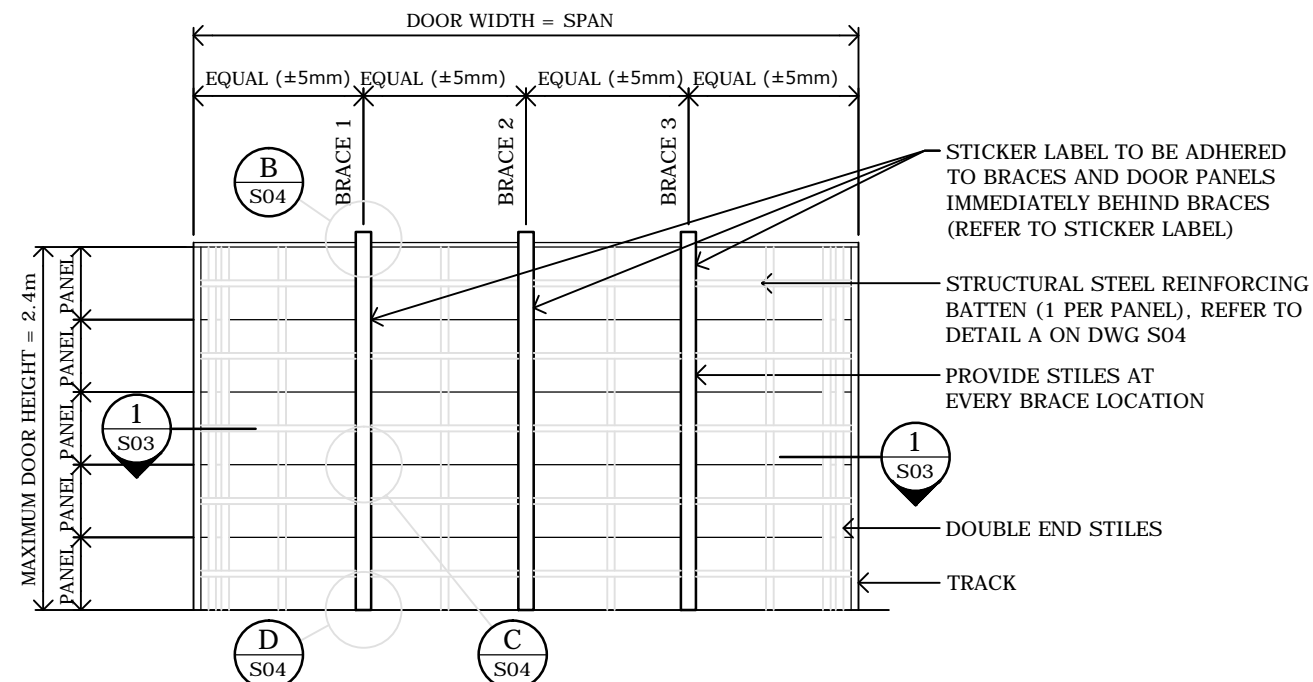

RD4 ELEVATION - B&D WINDPANEL™ DOOR 3.405m TO 4.3m DOOR WIDTH (THREE BRACES)
1:50

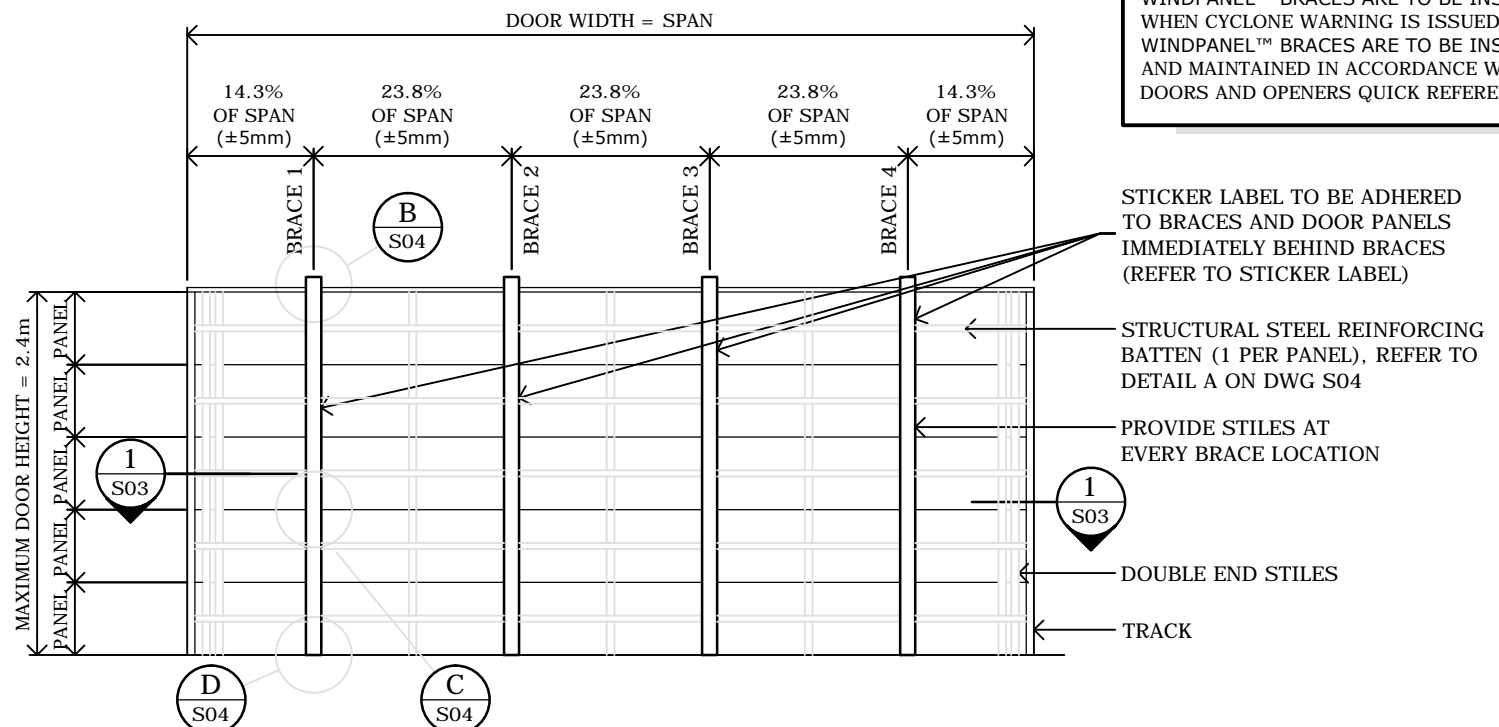

RD5 ELEVATION - B&D WINDPANEL™ DOOR 4.305m TO 5.5m DOOR WIDTH (FOUR BRACES)
1:50

NOTE: BRACE LOCATIONS FOR THIS CONFIGURATION CAN ALSO BE SPACED EQUALLY ALONG DOOR WIDTH.

STICKER LABEL TO BE INSTALLED ON ALL BRACED DOORS:

WARNING:
WINDPANEL™ BRACES ARE TO BE INSTALLED WHEN CYCLONE WARNING IS ISSUED. WINDPANEL™ BRACES ARE TO BE INSTALLED AND MAINTAINED IN ACCORDANCE WITH B&D DOORS AND OPENERS QUICK REFERENCE GUIDE.

STICKER LABEL TO BE ADHERED TO BRACES AND DOOR PANELS IMMEDIATELY BEHIND BRACES (REFER TO STICKER LABEL)

STRUCTURAL STEEL REINFORCING BATTEN (1 PER PANEL), REFER TO DETAIL A ON DWG S04

PROVIDE STILES AT EVERY BRACE LOCATION

DOUBLE END STILES

TRACK

- RD1 - REGION D, CONFIGURATION 1
- RD2 - REGION D, CONFIGURATION 2
- RD3 - REGION D, CONFIGURATION 3
- RD4 - REGION D, CONFIGURATION 4
- RD5 - REGION D, CONFIGURATION 5

ISSUE	DATE	AMENDMENTS
H	09.12.13	GENERAL REVISION
I	21.05.14	GENERAL REVISION
J	16.06.14	GENERAL REVISION
K	18.10.21	GENERAL REVISION
L	22.04.23	GENERAL REVISION

CLIENT	B&D AUSTRALIA PTY LTD
PROJECT	B&D WINDPANEL™ REINFORCED SECTIONAL DOORS WITH VERTICAL BRACES & TRACKLOCK

DRAWING	SECTIONAL DOOR ELEVATIONS FOR USE IN WIND REGIONS C4		SCALE
	JAMES ELLIS & ASSOCIATES PTY LTD Consulting Structural Engineers	DESIGNED	J.E.
		DRAWN	AAB
		CHECKED & APPROVED	
		DATE	Apr 2023
www.jamesellisengineers.com.au PO Box 251, Padstow NSW 2211 Ph: 8764 1035		DRAWING No.	S02L
		PROJECT No.	2191

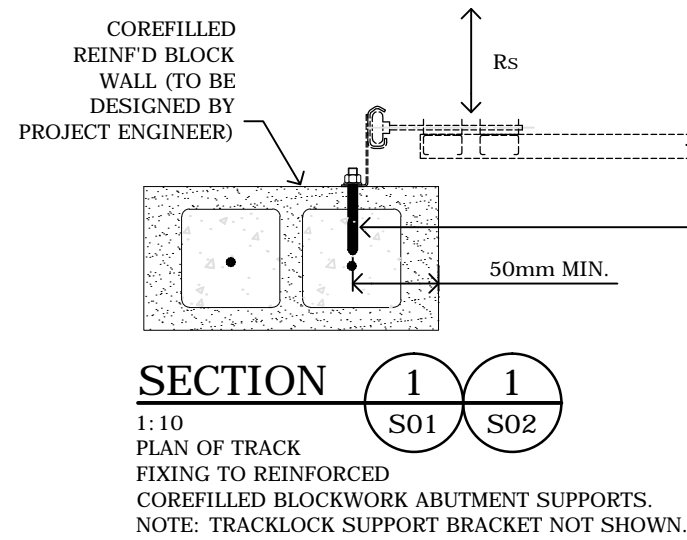
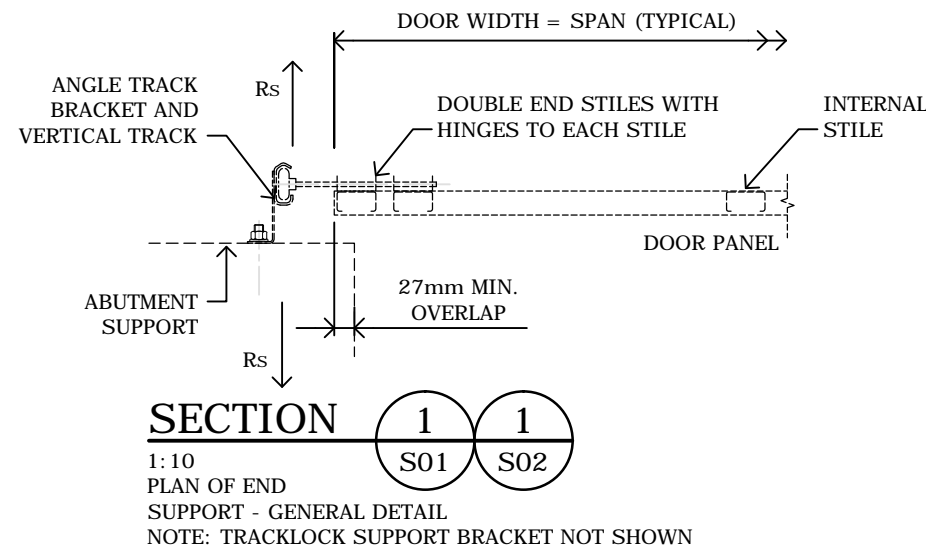

REGION C (RC1-3)
GALV. M8 RAMSET ANKASCREWS AT 400 CTS (60mm EMBEDMENT)
REGION D (RD1-5)
GALV. M8 RAMSET ANKASCREWS AT 300 CTS (60mm EMBEDMENT).
NOTE: ANKASCREWS ARE NOT TO BE LOCATED AT MORTAR BED JOINTS. PROVIDE A MINIMUM CLEARANCE OF 60mm FROM EDGE OF MORTAR JOINTS TO EDGE OF ANKASCREW FIXINGS WHERE REQUIRED.

BRACE REACTION TABLE		
ULTIMATE DESIGN WIND LOADS		
	R _b REACTION AT BASE OF BRACE (MAXIMUM PER BRACE)	R _t REACTION AT TOP OF BRACE (MAXIMUM PER BRACE)
RC1	N/A	N/A
RC2	8.3kN	7.48kN
RC3	8.39kN	7.7kN
RD1	N/A	N/A
RD2	7.80kN	7.80kN
RD3	8.4kN	8.22kN
RD4	9.36kN	8.70kN
RD5	11.31kN	10.32kN

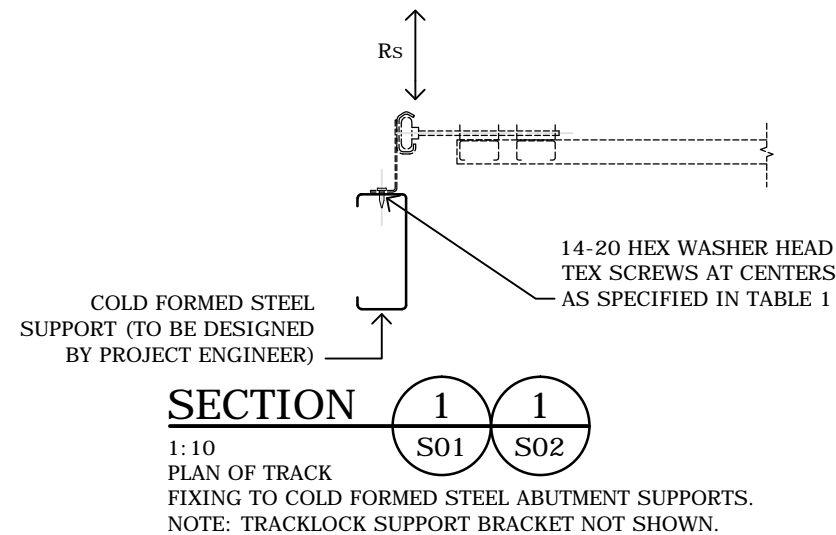
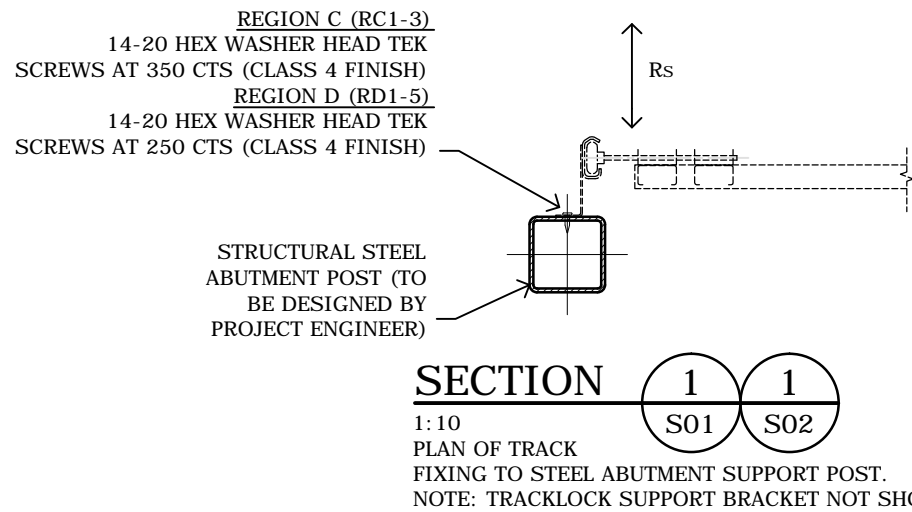

ABUTMENT LOAD TABLE	
ULTIMATE DESIGN WIND LOADS	
	R _s (PER METRE HEIGHT)
RC1	5.22kN/m
RC2	3.25kN/m
RC3	3.25kN/m
RD1	7.36kN/m
RD2	6.10kN/m
RD3	5.17kN/m
RD4	4.10kN/m
RD5	3.37kN/m

NOTE: STAINLESS STEEL TEK SCREWS IN LIEU OF CLASS 4 FINISH TEK SCREWS ARE TO BE USED IN HIGHLY CORROSIVE ENVIRONMENTS.

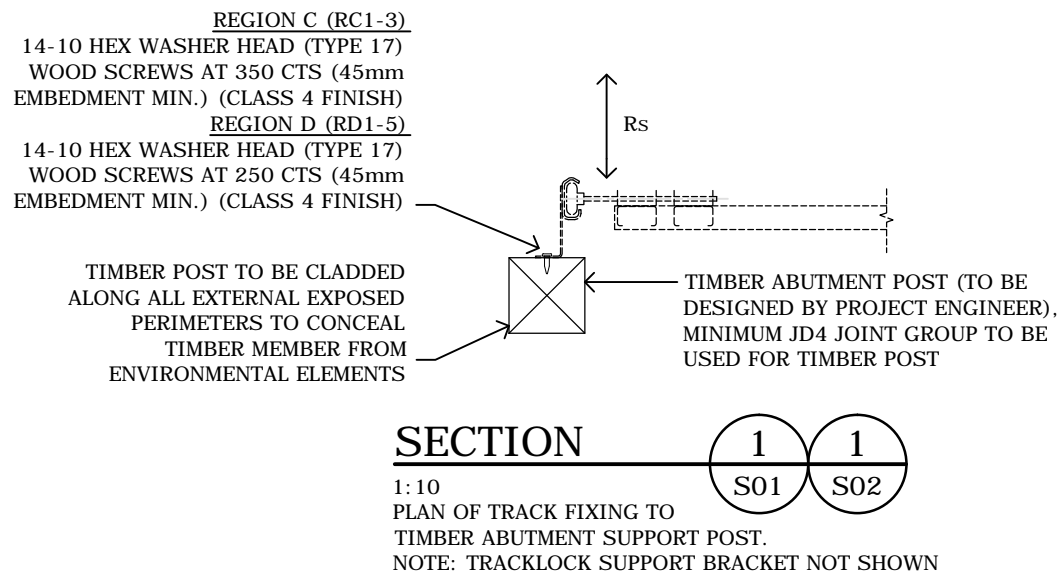

TABLE 1

FASTENING SPECIFICATIONS ONTO COLD FORMED STEEL ABUTMENT SUPPORTS COMPLYING WITH AS 1397-2021

CONFIGURATIONS	MATERIAL THICKNESS (t)mm	GRADE	YIELD STRENGTH	TENSILE STRENGTH	SPACING (mm)
RC1-3	1mm	G550	550 MPa	550 MPa	250mm
RC1-3	1.2mm	G500	500 MPa	520 MPa	300mm
RC1-3	1.5mm	G450	450 MPa	480 MPa	350mm
RC1-3	1.9mm	G450	450 MPa	480 MPa	400mm
RD1-5	1mm	G550	550 MPa	550 MPa	150mm
RD1-5	1.2mm	G500	500 MPa	520 MPa	200mm
RD1-5	1.5mm	G450	450 MPa	480 MPa	250mm
RD1-5	1.9mm	G450	450 MPa	480 MPa	300mm

ISSUE	DATE	AMENDMENTS
H	09.12.13	GENERAL REVISION
I	21.05.14	GENERAL REVISION
J	16.06.14	GENERAL REVISION
K	18.10.21	GENERAL REVISION
L	22.04.23	GENERAL REVISION

CLIENT B&D AUSTRALIA PTY LTD
PROJECT B&D WINDPANEL™ REINFORCED SECTIONAL DOORS WITH VERTICAL BRACES & TRACKLOCK

DRAWING SECTIONS AND TABLES	SCALE
JAMES ELLIS & ASSOCIATES PTY LTD Consulting Structural Engineers www.jamesellisengineers.com.au PO Box 251, Padstow NSW 2211 Ph: 8764 1035	DESIGNED J.E.
	DRAWN AAB
	CHECKED & APPROVED
	DATE Apr 2023

DRAWING No. S03L
PROJECT No. 2191

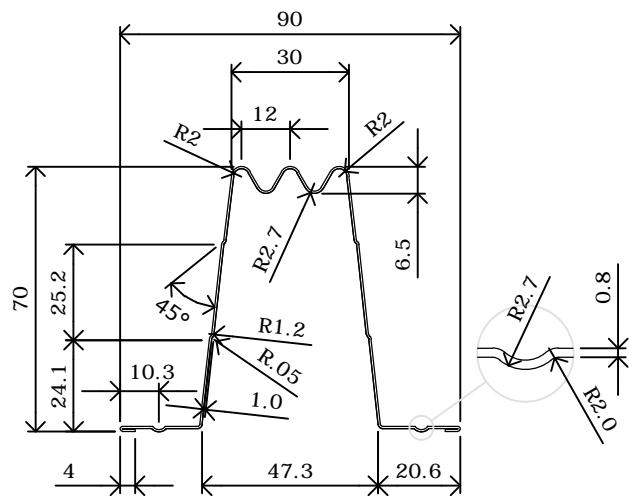

DETAIL A

1:2
STRUCTURAL STEEL
REINFORCING BATTEN - CROSS
SECTION - ELEVATION (TYPICAL)
MATERIAL: 0.7mm G550 GALVABOND

FASTENING INTO STEEL LINTEL
4 x (14-20) HEX HEAD TEK SCREWS
(CLASS 4 FINISH) WITH Ø17 WASHER or
3mm FILLET WELDS (REFER SECTION B1).
**FASTENING INTO CORE FILLED
REINFORCED BLOCKWALL**
4.M8 (RAMSET) GALV. ANKASCREWS
(60mm EMBEDMENT).
FASTENING INTO TIMBER LINTEL
4 x 14-10 HEX HEAD (TYPE 17) WOOD
SCREWS WITH Ø17 WASHERS (50mm
EMBEDMENT) (CLASS 4 FINISH)

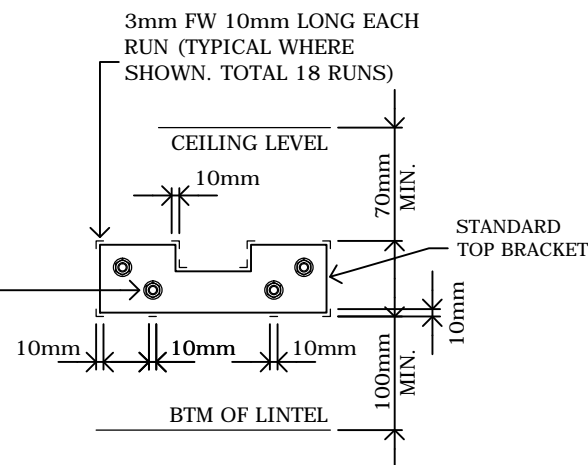

SECTION B1

1:10
TOP BRACKET FIXING
DETAIL (ELEVATION).
NOTE: PROTRUDING LIP OF TOP BRACKET
NOT SHOWN FOR CLARITY PURPOSES

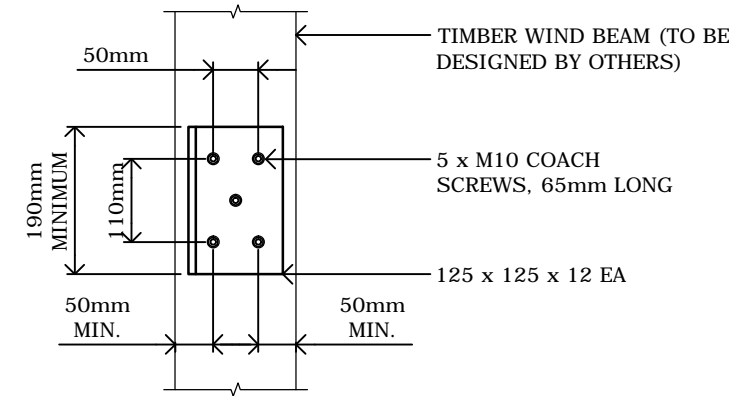

SECTION E

1:10

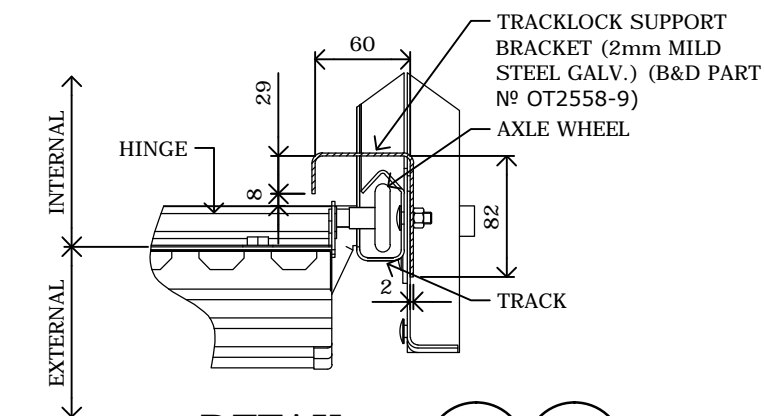
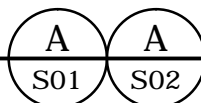

DETAIL F

1:5

TRACKLOCK SUPPORT BRACKET - PART PLAN (CROSS SECTION)

NOTE: DETAIL TO APPLY TO RC1 AND RD1 ONLY

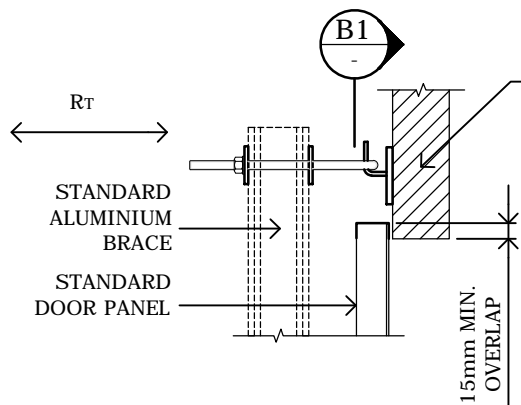

REINFORCED CORE FILLED
BLOCKWALL, TIMBER OR
STEEL LINTEL (TO BE
DESIGNED BY PROJECT
ENGINEER) (MINIMUM JD4
JOINT GROUP TO BE USED
FOR TIMBER) (TIMBER
MEMBERS TO BE
CONCEALED FROM
ENVIRONMENT)

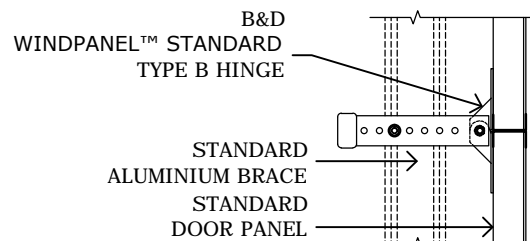

DETAIL C

1:10
ALUMINIUM BRACE TO
PANEL INTERSECTIONS
TYPICAL (ELEVATION)

DETAIL B

1:10
ALUMINIUM BRACE
TO TOP BRACKET - ELEVATION (TYPICAL)

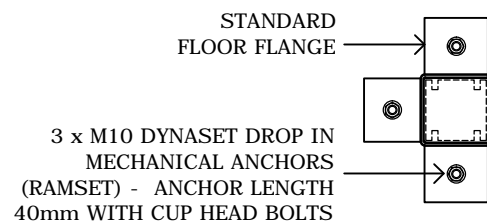

SECTION D1

1:10
PLAN - FLOOR FLANGE
BASE FIXING DETAIL

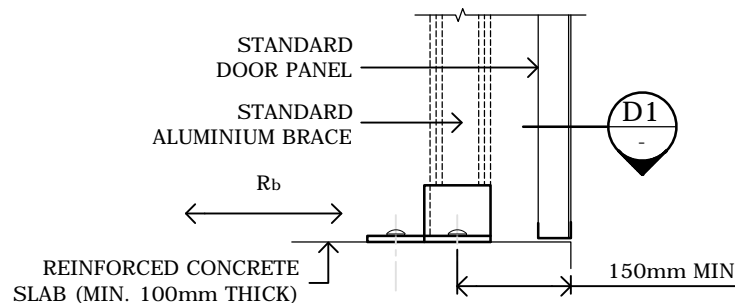

DETAIL D

1:10
ALUMINIUM BRACE
TO CONCRETE SLAB BASE - ELEVATION (TYPICAL)

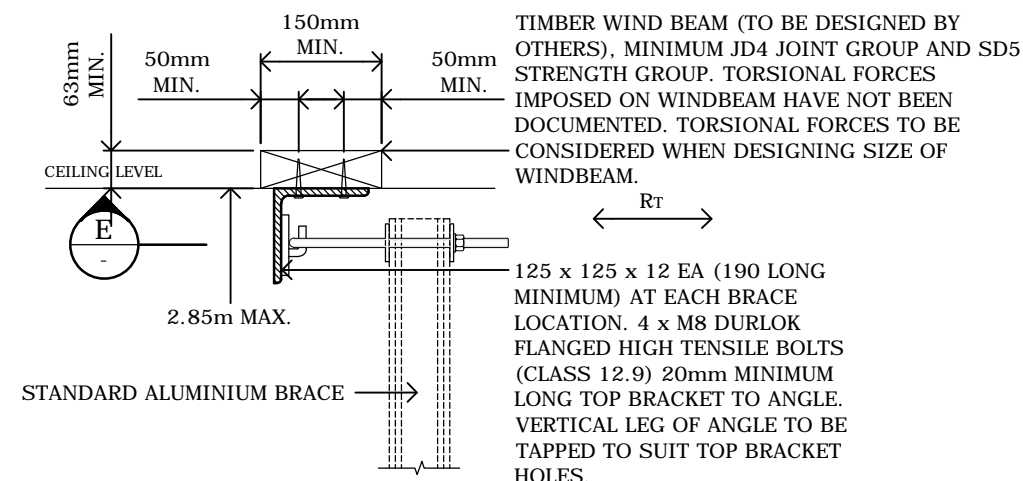

ALTERNATIVE - TOP BRACKET FIXING DETAIL (ELEVATION)

TO BE APPLIED TO RC1-3 ONLY

1:10

ISSUE	DATE	AMENDMENTS
H	09.12.13	GENERAL REVISION
I	21.05.14	GENERAL REVISION
J	16.06.14	GENERAL REVISION
K	18.10.21	GENERAL REVISION
L	22.04.23	GENERAL REVISION

CLIENT	B&D AUSTRALIA PTY LTD
PROJECT	B&D WINDPANEL™ REINFORCED SECTIONAL DOORS WITH VERTICAL BRACES & TRACKLOCK

DRAWING TYPICAL SECTIONS, PLANS, ELEVATIONS AND DETAILS OF BRACED SECTIONAL DOOR COMPONENTS

JAMES ELLIS & ASSOCIATES PTY LTD
Consulting Structural Engineers

www.jamesellisengineers.com.au
PO Box 251, Padstow NSW 2211
Ph: 8764 1035

SCALE	DESIGNED	J.E.
	DRAWN	AAB
	CHECKED & APPROVED	[Signature]
	DATE	Apr 2023

DRAWING No.	S04L
PROJECT No.	2191