



b&d

The Designer Series

Flushmount Door

installation instructions

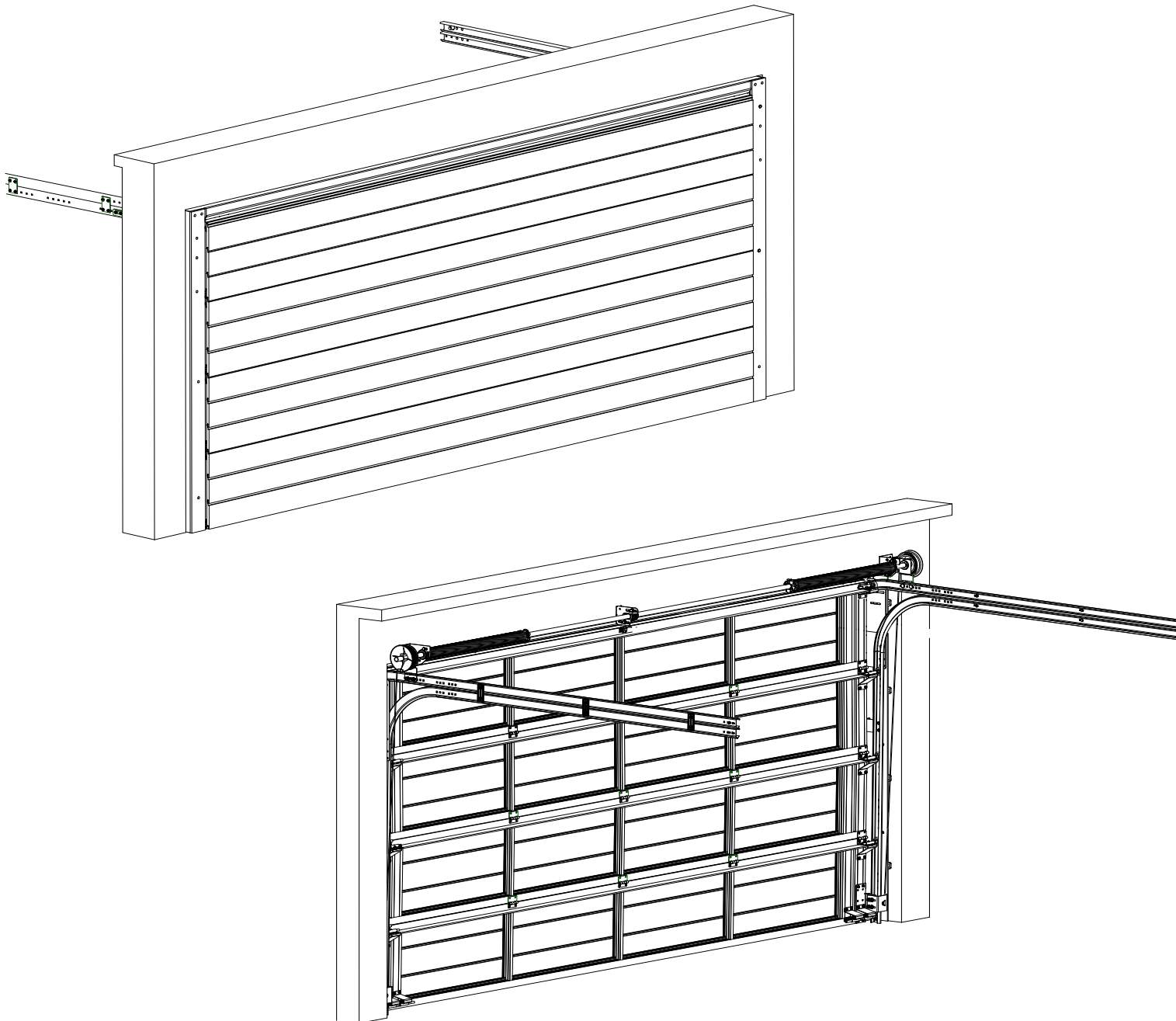

These instructions are intended for professional garage door installers. All references are taken from inside looking out.

DOC# 165008 04
RELEASED: 19/09/23

www.bnd.com.au



b&d

contents

1.0 before you begin	3
1.1 installation safety warnings	3
1.2 fastener recommendations for fitting garage doors	4
1.3 parts checklist	5
1.4 requirements before installation	6
1.4.1 measurements & requirements	6
1.4.2 initial calculations	6
1.5 tools	6
2.0 assembly	7
2.1 assemble the frame	7
2.2 assemble the vertical tracks	7
2.3 bottom panel	8
2.4 middle panel	9
3.0 installation	10
3.1 install the tracks	10
3.2 install the temporary boards	10
3.3 installing the panels	11
3.4 assemble horizontal track	13
3.5 installing top panel	14
3.6 spring counterbalance system	15
3.7 adding tension to spring	16
3.8 final checks	17
4.0 troubleshooting	18
5.0 appendix	20
5.1 after installation care	20

1.0 before you begin

1.1 installation safety warnings

This B&D Door is designed and tested to provide security, attractive appearance and smooth , low effort operation provided it is installed and operated in strict accordance with the following safety warnings. Failure to comply with the following instructions may result in death, serious personal injury or property damage.

NOTE: No guarantee will be given or responsibility accepted by the manufacturers if the door is not installed as instructed.



WARNING!

Crush injury from unsecured door

Tension Springs

- Place a 2 metre exclusion zone around area under the garage opening while installing door. If sufficient area is not available DO NOT install door.
- Follow the installation instructions.
- Ensure correctly fitting winding bar is used.
- Ensure the correct length winding bar is utilised.
- Ensure winding bar is placed appropriately in the torsion socket plug.
- Ensure correct bolts are tightened or loosened (or clamp pliers) to ensure there is no release or controlled release of energy from the spring either through the torsion bar or the winding bar.
- Keep hands clear of the torsion plug at all times.
- Keep head clear of the tensioning bar at all times.



ELECTROCUTION!

- Check risk assessment for any highlighted electrical power concerns.
- Ensure power source is isolated prior to commencement of job.
- Turn off electricity to site when necessary.
- Ensure you check the substrate for electrical wiring prior to penetration.
- Wear rubber soled footwear.



LACERATION:

- Wear appropriate PPE (Dyneema cut off gloves) and keep hands well clear of pinch points.
- Follow instructions explicitly, particularly for the installation of some parts of the panel doors, as the unrolled cut out edges presents a very sharp edge.



CAUTION:

Muscular strain

Fall from ladder

Hand Tools

Entanglement

- Practice correct lifting techniques when required.
- Use mechanical aids such as lifting devices, forklift and cranes where possible.
- Avoid twisting.
- Ensure ladder is the correct type for job.
- Ensure ladder is on flat firm ground that will take the weight without the legs sinking.
- Ensure user has 3 points of contact while on ladder.
- Wear appropriate PPE and utilise operators manual of all tools.
- Use appropriate noise/hearing protection in the form of ear plugs or ear muffs.
- Ensure appropriate fire protection available and housekeeping to ensure that flammable liquids or materials are removed from the area of work.
- Keep hands and loose clothing clear of moving door and guides at all times.
- Depending on the size of the door, this product may requires a two person lift. Use proper techniques and equipment to lift the door from the trailer and into position.



TWO PERSON LIFT:

1.2 fastener recommendations for fitting garage doors

substrate type	fastener required	washer required	plug required	drilled hole \varnothing (mm)	min hole depth (mm)		B&D fastner pack	
					Unlined	Plaster Lined	100pk	500pk
solid brick (>10 MPa)	screw, coach 5/16 - 9tpi x 50	washer flat M8	plug, nylon 5/16 x 50	10	60	90	FK0011	FK0012
three hole brick (> 30 MPa)	screw anka M8 x 75 flange hex head	washer 3/8"	n/a	8	75	75	FK0024	FK0023 (50PK)
ten hole brick (>15 MPa)	screw anka M8 x 75 flange hex head	washer 3/8"	n/a	8	75	75	FK0024	FK0023 (50PK)
concrete block (> 8 MPa)	screw anka M8 x 75 flange hex head	washer 3/8"	n/a	8	75	75	FK0024	FK0023 (50PK)
concrete (> 15 MPa)	screw, coach 5/16 - 9tpi x 80	washer flat M8	plug, nylon 5/16 x 80	10	60	90	FK0013	FK0014
timber	screw, coach 5/16 - 9tpi x 50	washer flat M8	n/a	5	60	90	FK0011	FK0012
steel section (0.9-2mm thick)	screw tek 14g - 20tpi x 25 flange hex head ZP	washer flat M8	n/a	n/a	n/a	n/a	FK0019	FK0020

important notes

1. For installation to substrate materials not covered in the above chart, the installer should seek expert advice.
2. Substitute fasteners are not recommend unless approved.
3. The above chart specifies the fasteners for new substrate materials only. Seek specialist advice regarding pre-existing substrate materials.
4. It is important that correct washer and plug is used and the correct pilot hole drilled where specified.



WARNING!

The installer must select and use fasteners appropriate to the material into which they are being fixed.

1.3 parts checklist

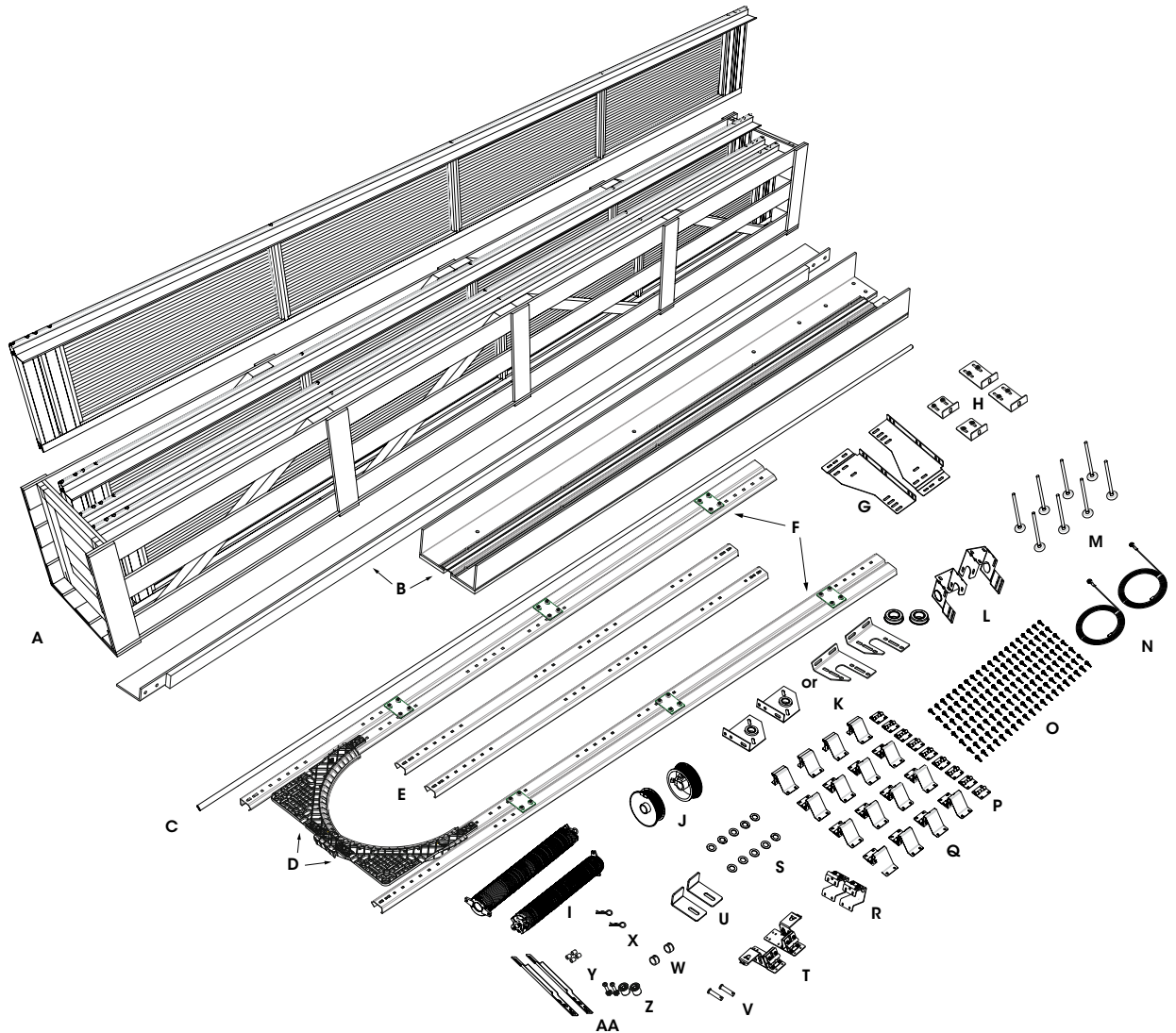

ITEM	DESCRIPTION	QTY
A	PACK OF DOOR PANELS	1
B	ALUMINIUM FRAME LENGTHS	3
C	TORSION BAR	1
D	POLYPROPYLENE CURVE	2
E	VERTICAL TRACKS	2
F	HORIZONTAL TRACKS	2
G	FLAG BRACKET	2
H	SMALL ANGLE JAMB BRACKETS (2 SIZES)	2+
I	TENSION SPRING	1-4
J	CABLE DRUMS	2
K	SPRING ANCHOR BRACKET	1
	HD ANCHOR BRACKET + 2" ROLLER BEARING	2
L	SIDE BEARING COMBO BRACKETS	2
M	WHEEL AXLES	8+

ITEM	DESCRIPTION	QTY
N	LIFTING CABLE	2
O	TEK SCREWS	2
P	HINGES	9+
Q	END HINGES	16
R	TOP HANGER	2+
S	WASHERS	10
T	BOTTOM HANGERS	2
U	STOPPER PLATE	2
V	CLEVIS PINS	2
W	SHAFT COLLAR	2-4
X	COTTER PINS	2
Y	AXLE SPACER	4
Z	SAFETY STOP	2
AA	HORIZONTAL BRACKET	2

tip An extended impact drive 152mm & 3/8 socket is required for installation



1.4 requirements before installation

mounting - The door is designed to be mounted in the opening to a frame that is protruding forwards.

obstructions - Ensure that the surface where the door will be fitted is smooth, and the area behind and in front of the opening is free from any protrusions.

structural suitability - Ensure the opening is strong enough to support the door. If unsure, consult a builder.

level and plumb - The door must be installed in an absolutely level position, if opening is not level and square, appearance will be affected. The floor should be level or recessed across the opening to avoid gaps.

1.4.1 measurements & requirements

opening width - as the flush mount frame will sit within the jamb, the frame needs to be narrower than the opening (recommended 10-20mm but will be dependent on the squareness of the opening). The door will sit within the flush mount frame and will be 240mm narrower. See Fig 1.4.1.

opening height - the flush mount frame will sit within the jamb, therefore the frame needs to be shorter than the opening height (recommended 10mm but will be dependent on squareness of the opening). The door will sit flush within the flush mount frame and will be 90mm lower than frame.

headroom - standard headroom with a residential opener will be 150mm or 185mm for an industrial opener.

sideroom - the flush mount frame will require no sideroom. However, allow for 50mm on either side of the opening for cables and drums to operate the door.

backroom - as the door extends into the garage when opening a minimum of the door height + 300mm for tracks is required (+ 1000mm if opener fitted).

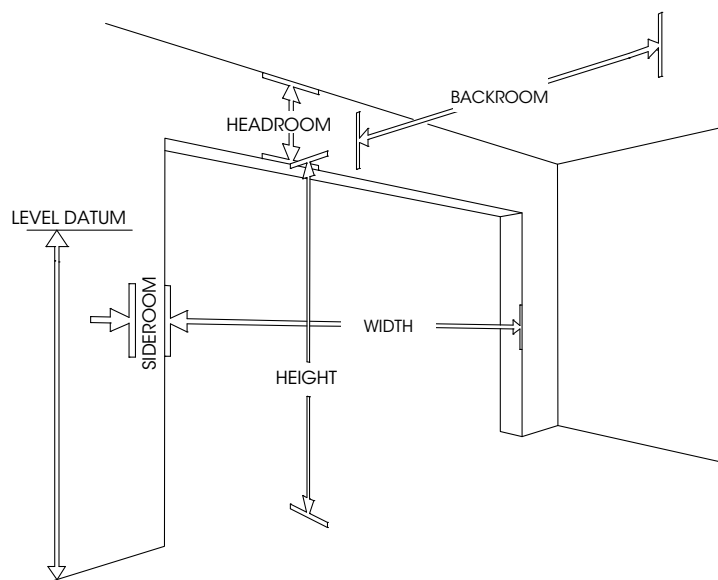

Fig: 1.4.1

level datum - use a water or lazer level to mark a datum line on both sides approx. 1.5m from the floor. Use this line to compare the distance on each side to the opening height to determine if the opening is level.

position of frame - measure the distance of the battons to the wall on the exterior of the building. If the battons are not in place obtain this information from the builder before proceeding.

cladding - obtain a sample piece of the cladding or measure the cladding on the door panel and use a substitute that is of the same depth. Refer to appendix for details on how to install biowood panels.

1.4.2 initial calculations

- Open the package of door panels and measure the depth of the cladding on the panel ①.
- Measure the distance of the battons from the wall ②. If battons not in place, obtain this information from the builder in order to proceed. See Fig 1.4.2.
- Calculate the horizontal track brace position by referring to the noggin detail information on the [B&D website](#) for flushmount brace positions.

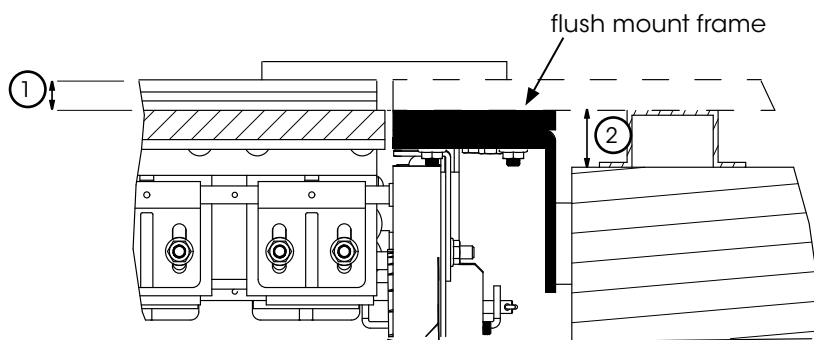

Fig: 1.4.2

1.5 tools

It is recommended that this door is installed by a professional door installer using a professional and specialised tool kit, including;

- Impact driver
- Drill & drill bits
- Extension 152mm & 3/8 socket
- Range of various thickness plastic window packers
- Long spirit level
- 2 x (35 x 90mm) boards



Carry a set of 4 x 1-2mm thick spacers within the installer kit.



2.0 assembly

2.1 assemble the frame

- a) Refer to the Fastener table in section 1.2 to determine the size of the drill holes and fasteners required to fit the frame to the door jamb.
- b) Start by drilling holes in the vertical frame, 200mm from the top and bottom and then at intervals no greater than 600mm, ensuring the fixing holes are aligned with the jamb substrate. Fig 2.1.1.



Using the level datums, identify the highest side of the floor levels. Working from the high side first, when securing the vertical track to the door jamb.

- c) Use a level, check that the frame is vertical in both planes and then using the appropriate window packers at each fastening point, fix the frame vertically, ensuring the ply face aligns with the external face of the substrate.



Before fixing, check the frame position relative to the cladding support system ② as per Fig 2.1.2.

- d) Once the vertical frame is set, work along the top horizontal frame.
- e) Holes in the horizontal frame can be placed 200mm from each end, one in the centre and then evenly spaced at no more than 1200mm intervals. Fig 2.1.1
- f) Attach the top frame with two (2) bolts to the previously fitted vertical frame. Fit one (1) fixing to the opposite end for support and adjustments only.
- g) Continue to work down the remaining vertical frame with the same method as steps b) & c).
- h) Place and tighten the fixings to head frame ensuring it is perfectly level.

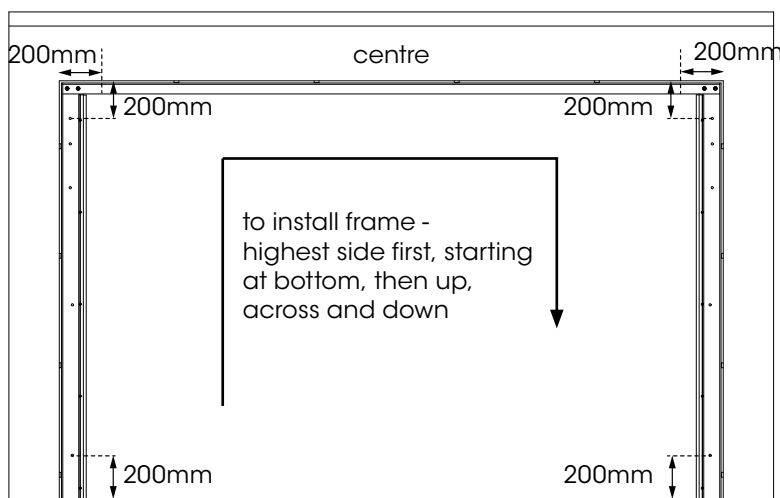

Fig: 2.1.1

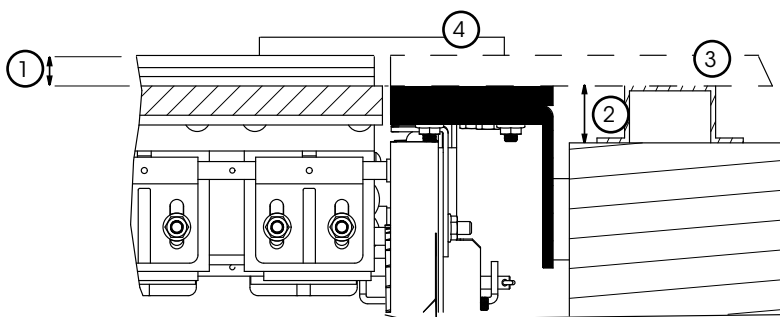

Fig: 2.1.2

2.2 assemble the vertical tracks



door height

=

376mm

=

* vertical track length

- a) Affix the polypropylene curve (D) and flag bracket (F) to the vertical straight track (E) using 5/16 flat head bolts and wiz nuts.



The small angle jamb brackets (G) and the flag bracket (F), provide adjustable slots to move the track out from the frame. Use the smaller of the small angle jamb brackets at the bottom of the track and set to 70mm as per Fig 2.2.1. Set the vertical track flag bracket (F) connection to 95mm for a 4 panel door.

- b) Align the small angle jamb brackets (G) with the predrilled holes in the frame and affix to the vertical track using 1/4 flat head bolts and wiz nuts.

* Tracks are precut to size, confirm lengths before installing

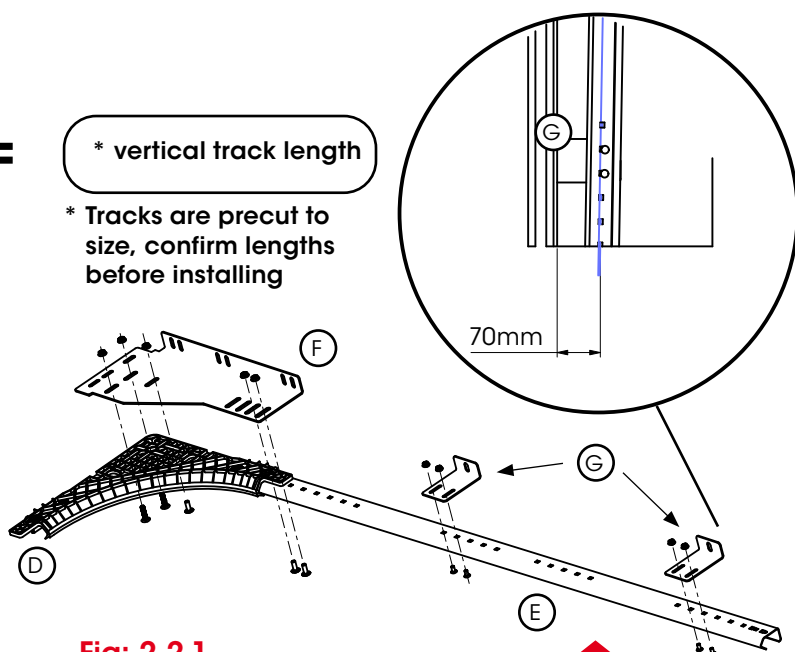

Fig: 2.2.1

right hand track shown



2.3 bottom panel

- a) Open up the pack of door panels, making sure the bottom panel (weather strip seal on the bottom of the panel and bottom hinge hole) is on top of the pack. Start with the bottom panel.
- b) Place the bottom hanger (T) onto the bottom panel, flush with the side and bottom of the end stile as shown in Fig 2.3.1a using four (4) tek screws (O).

! tip Apply general purpose grease to all axles before fitting them.

- c) Before secure the end hinges (Q) using eight (8) tek screws, remove the 2 axle plates (ii), nuts and washers from each hinge and put aside for later, leaving the screws in the hinge (Fig 2.3.1b).
- d) Push the end of each lifting cable (N), onto the bottom hanger, followed by a washer (S) and secure with a clevis pin (V) & cotter pin (X) Fig 2.3.1a.

! tip Do not unwind lifting cable until specified to do so.

- e) Repeat steps b) to d) for other side of the panel.

- f) Attach a hinge (P) to the top of the panel at every door stile, measuring 15mm down from the top of the panel to mark the centre screw position. (with the oil hole facing up) ensure alignment with other hinges across the panel before, secure with 2 tek screws (Fig 2.3.2a).

- g) Before placing 2 end hinges (Q) at either end of the panel, remove the 2 axle plates (ii), nuts and washers from each hinge and put aside for later, leaving the screws in the hinge (Fig 2.3.2b).

- h) The fixings must align with the vertical grooves in the stile then, measure 15mm down from the top of the panel to mark the centre screw position of each of the end hinges (Q) to ensure horizontal alignment with hinges (P). Secure with eight (8) tek screws as shown in Fig 2.3.2c.

! tip Ensuring the hinges (P) and (Q) are horizontally aligned across the panel will provide a smoother door operation (Fig 2.3.2d).

NOTE: Once all the panels are in place the hinged hangers (Q) can be adjusted if needed to ensure the panels are parallel to the opening.

- i) Repeat steps g) and h) for the other side of the panel.

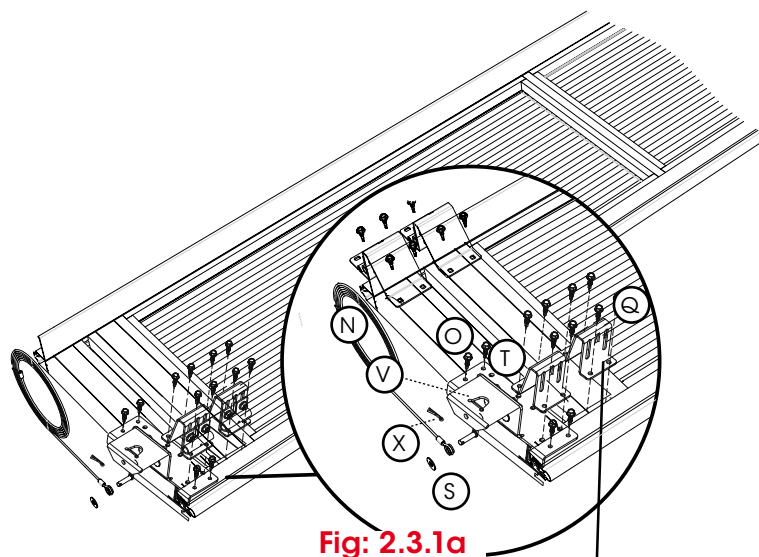

Fig: 2.3.1a

Fig: 2.3.1

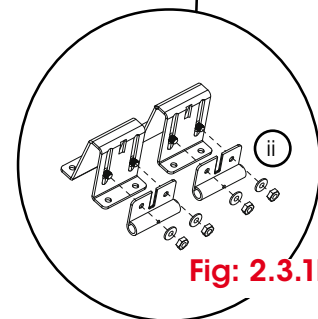

Fig: 2.3.1b

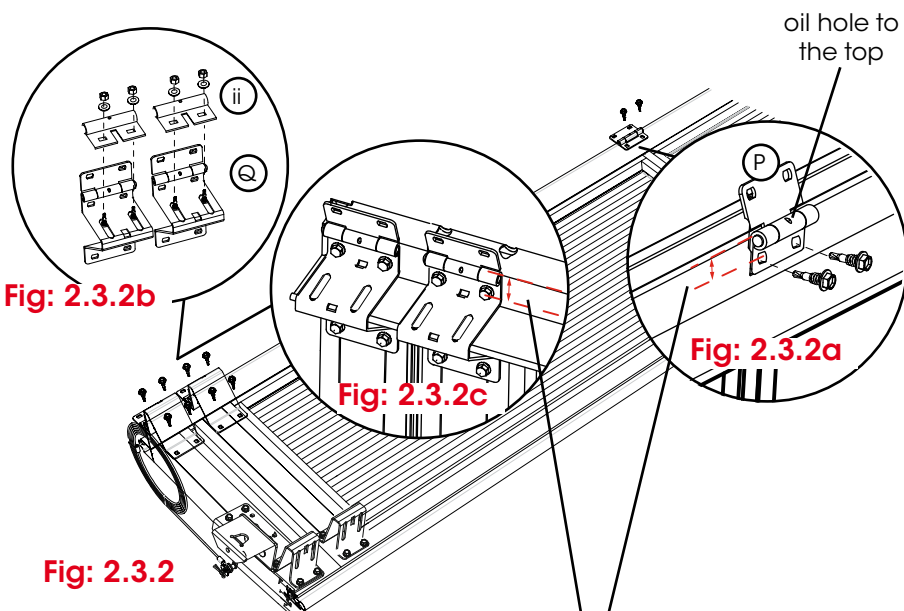

Fig: 2.3.2b

Fig: 2.3.2c

Fig: 2.3.2a

Fig: 2.3.2

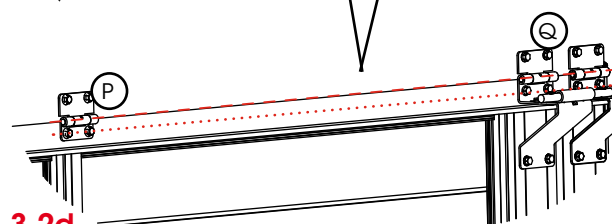

Fig: 2.3.2d

2.4 middle panel

- a) Attach a hinge (P) to the top of the panel at every door stile using an installation tool to ensure alignment, with 2 tek screws (Fig 2.4.1a).
- b) Before placing 2 end hinges (Q) at either end of the panel, remove the 2 axle plates (ii), nuts and washers from each hinge and put aside for later, leaving the screws in the hinge (Fig 2.4.1b).

! tip Apply general purpose grease to all axles before fitting them.

- c) The fixings must align with the vertical grooves in the stile then, measure down 15mm from the top of the panel to mark the centre screw position of each of the end hinges (Q) to ensure horizontal alignment. Secure with eight (8) tek screws as shown in Fig 2.4.1c.

NOTE: Once the panel is in place the hinged hangers (Q) can be adjusted if needed to ensure the panels are parallel to the opening.

! tip Ensuring the hinges (P) and (Q) are horizontally aligned across the panel will provide a smoother door operation (Fig 2.4.1d).

- d) Repeat steps to complete other side of the panel and then assemble other middle panels.

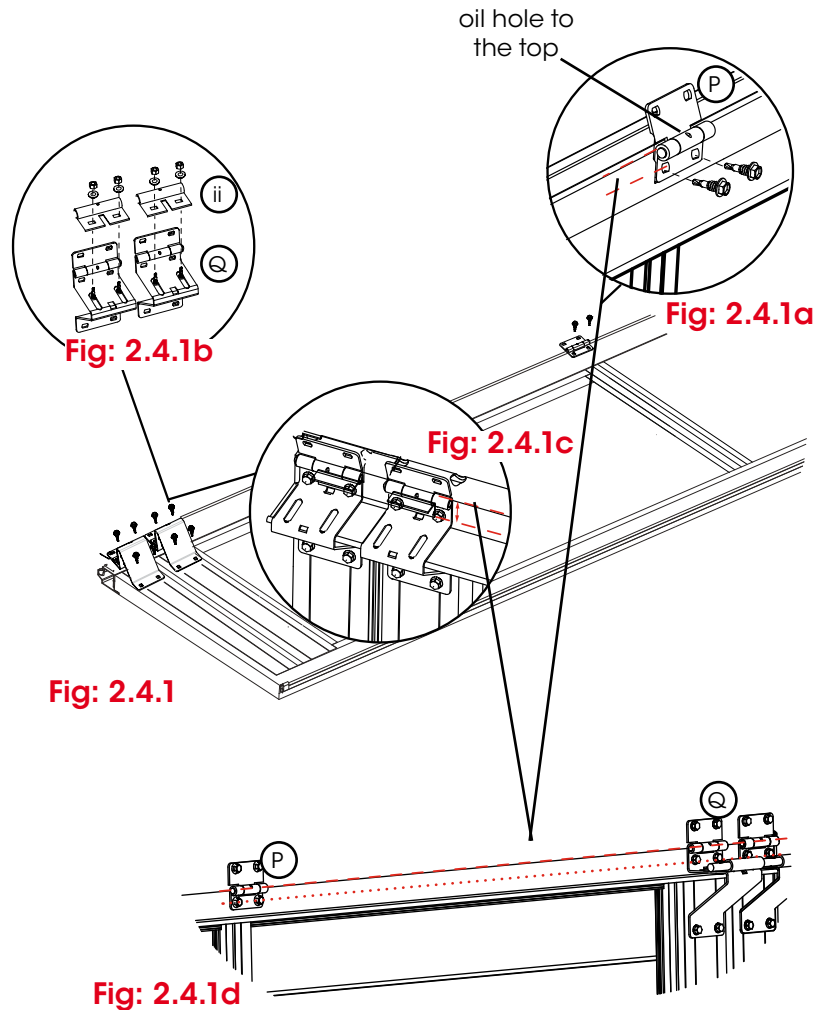

3.0 installation

3.1 install the tracks

- Insert $\frac{5}{16} \times 1 \frac{1}{4}$ flat head square neck bolts into the 5 vertical holes on the frame from the front of the opening. Place the adjustable jamb brackets over bolts and loosely fasten using $\frac{5}{16}$ flange nuts.
- Vertically align the inside of the track with the inside of the flushmount frame using a straight edge.
- The tracks should be panel width + 20mm apart. Use the level/datum marks to ensure the tracks are level with each other and the same distance to the top of the track or the door will not function correctly.
- Ensure to set the bottom adjustable jamb bracket to 70mm from the back of the frame to the centre of the bolt, Fig 3.1.1. Set the vertical track flag bracket (F) connection to 95mm for a 4 panel door.
- Once satisfied temporarily fix in position with at least three (3) fixings to the top bracket and one to each of the lower track brackets. These will hold the tracks in position and allow for minor adjustments.



Giving the track some movement will assist in manouvering the wheel axles of the bottom panel into the track.

3.2 install the temporary boards

- Place a sample piece of cladding (3) or substitute that is same depth as measurement (1) on top of frame. See Fig 2.1.2.
- Take one of the boards from your required tool kit and secure both it (4) and the sample cladding (3) to the frame as in Fig 3.2.1.
- Repeat steps a) and b) for other side of door.

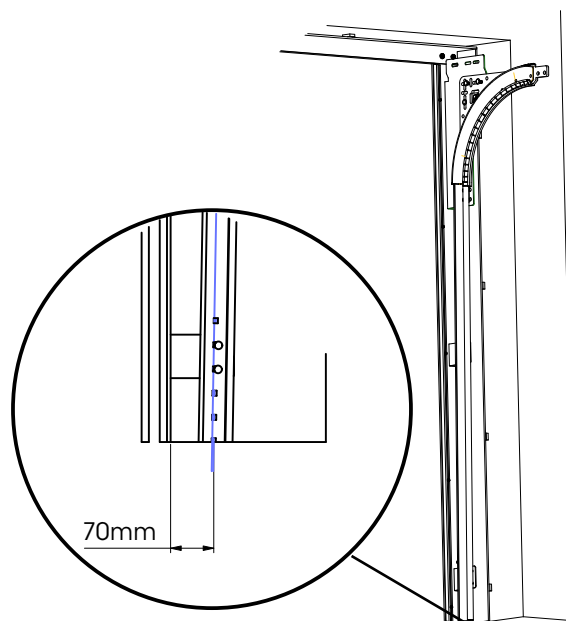

Fig: 3.1.1

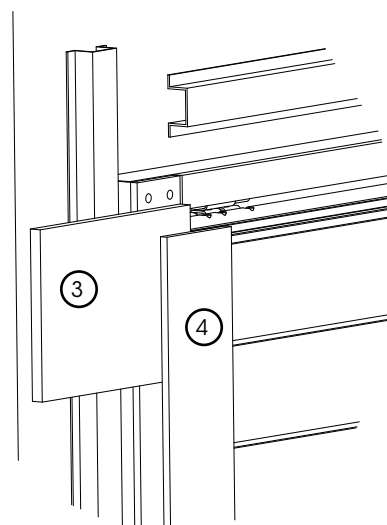

Fig: 3.2.1

3.3 installing the panels



TWO PERSON LIFT: depending on the size of the door, this process may require two persons to lift into place.

- a) Carefully move the bottom panel into position between the tracks as per Fig 3.3.1.



Apply general purpose grease to all axles before fitting them.



The axle plates may need to be rotated 180° if the cladding is >18mm thick.

- b) Slide the axles spacer (Y) and the axle plates (ii) (that were removed in step 2.3c) onto the wheel axle (M) and position into the vertical track from the bottom and move upwards to mount on the hinge hanger (Q) Fig 3.3.1c.
- c) Slide in wheel axle (M) through 2 axle plates (that were removed in step 2.3f) and fit the wheel into the vertical track, before lowering down onto end hinges. (Fig 3.3.1a or 3.3.1b) Secure axle plates with 4 tek screws as shown.
- d) Repeat step b) and c) for other side of panel. Adjust axle carrier forward or backwards before lowering panel to the ground.



CAUTION: Bottom panel must be horizontal and level. Use packers if required to make level before installing middle panels.

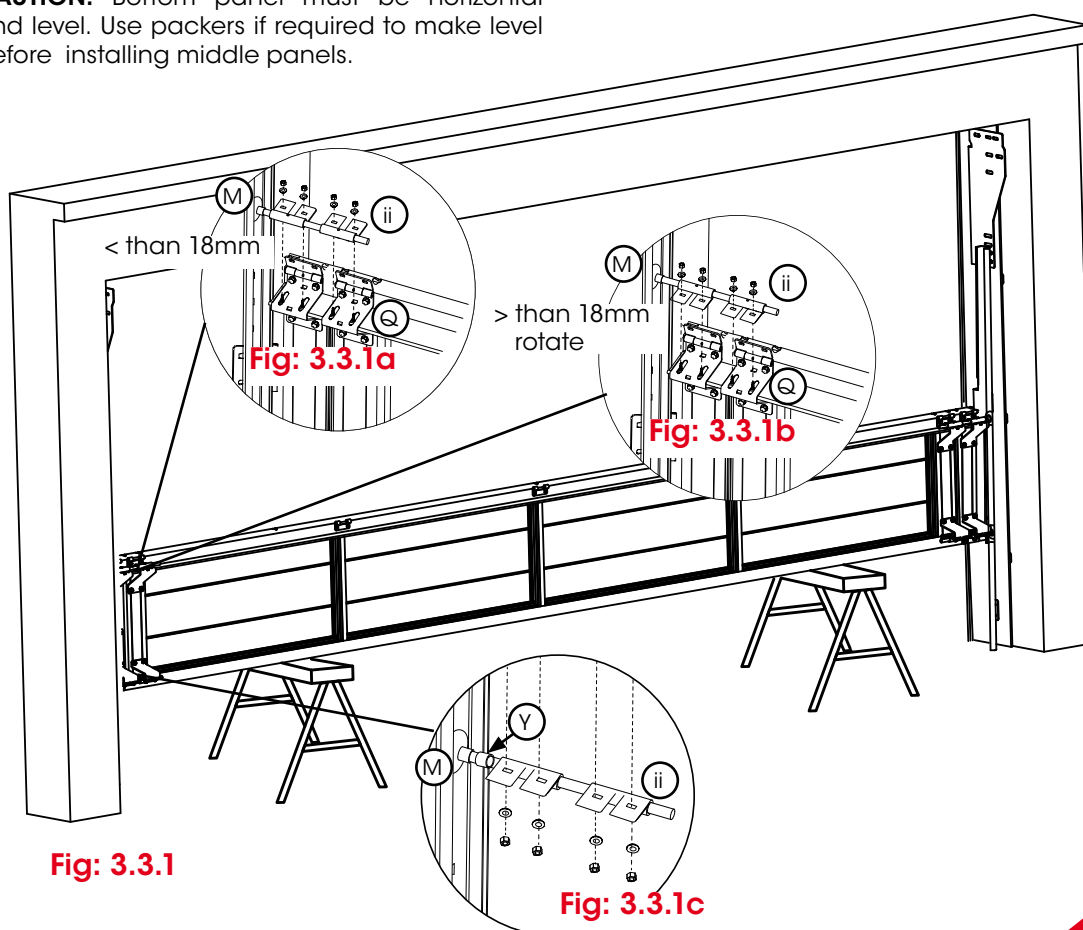

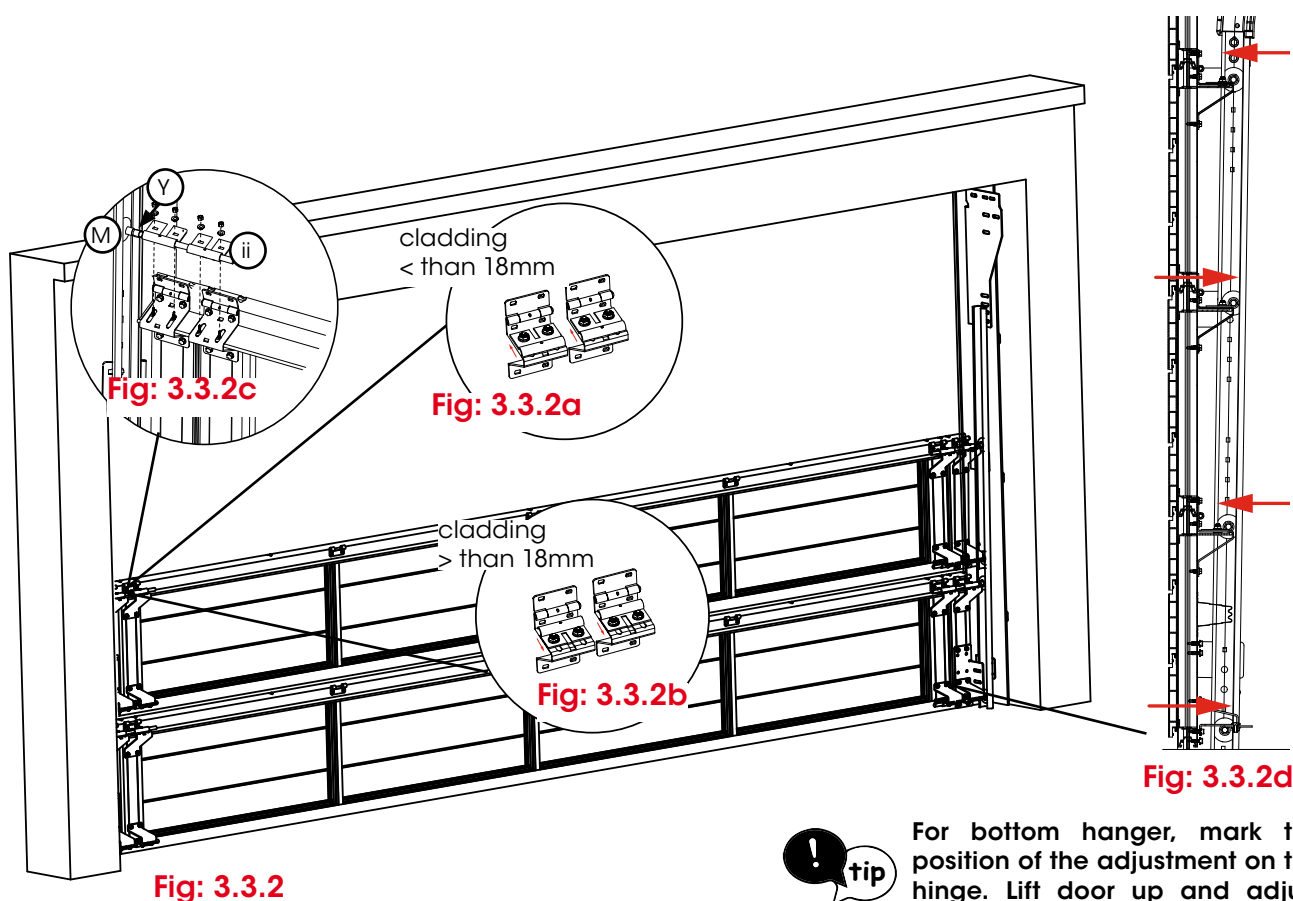

! tip For bottom hanger, mark the position of the adjustment on the hinge. Lift door up and adjust to mark and check. Repeat if necessary.

- e) Before adding the next panel, fit a temporary spacer, 1-2mm thick, at each panel joint to give clearance between each panel. Carefully move the second panel into position between the tracks and lower to rest on top of spacers Fig 3.3.2.
- a) **For the first middle panel:**
Slide the axles spacer (Y) and the axle plates (ii) (that were removed in step 2.3c) onto the wheel axle (M), position into the vertical track before sliding down to the hinge hanger.
- For all other middle panels:**
Slide the axle plates (ii) onto the wheel axle (M), position into the vertical track before sliding down to the hinge hanger as per 3.3.1a and 3.3.1b.

- b) To ensure the panels are aligned to the front, start with the bottom wheel axle and adjust the hinged hanger (Q) so the wheel is positioned towards the **back** of the track as per Fig 3.3.2d.
- c) Repeat this procedure for all other panels (with the exception of the top panel which is positioned after the horizontal track is installed) proceeding upwards to the next wheel and adjust hinged hanger so the wheel is positioned to the **front**.
- d) Screw the hinges (P) and end hinges (Q) from the bottom panel to the middle panel Fig 3.3.3.
- e) Once satisfied with the door placement, secure **ALL** fixing points on the vertical tracks.

! tip Ensure the face of both panels are flush with the temporary board (4) from fig 3.2.1 on the front of opening. To adjust, move the hinge plates on (Q) closer to OR away from the door as in Fig 3.3.2a & b.

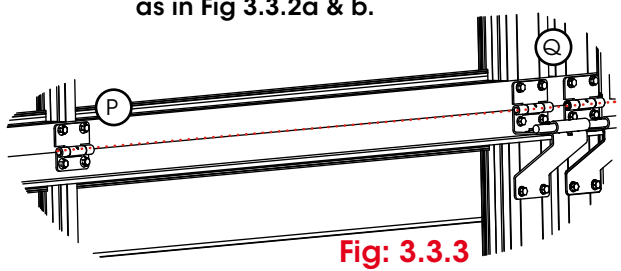

! tip Ensuring the hinges (P) and (Q) are horizontally aligned across the panel will provide a smoother door operation (Fig 3.3.3).

! CAUTION: DO NOT remove plastic protective film from panels until the temporary board is removed.



3.4 assemble horizontal track

- a) Lift the horizontal track (E) into position and secure to the flag bracket using 6 x 5/16 flat head bolts and wiz nuts.

WARNING! The plate stopper must be installed. Failure to do so may cause serious personal injury or damage to property.

- b) Install the plate stopper (U) from the outside of the top of the flag bracket and through both the top track and the flag bracket using 5/16 flat head bolts as shown in Fig 3.4.1.

- c) Place the horizontal bracket (AA) on each horizontal track as shown in Fig 3.4.1 and install the safety stop (Z) at the end of each **top** horizontal track.

Before bracing the horizontal tracks, ensure that they are square to the opening and level. To check whether your diagonals are equal:

- d) Measure from the top of the vertical track to the end of the opposite horizontal track Fig 3.4.2.

- e) Check both sides. Adjust if necessary.

The track support/s must be located along the horizontal track and secured into ceiling beams Fig 3.4.3.

- f) Measure along the horizontal track to 2000mm and find a structurally sound beam to fix your support to the ceiling. Fig 3.4.2 for single supports.

WARNING! For all doors higher than 2450mm and wider than 4700mm, two (2) ceiling supports must be fitted per horizontal track at 1300mm & 2600mm Fig 3.4.4.

WARNING! For doors over 150kg (8m²) we recommend using heavy duty ceiling supports

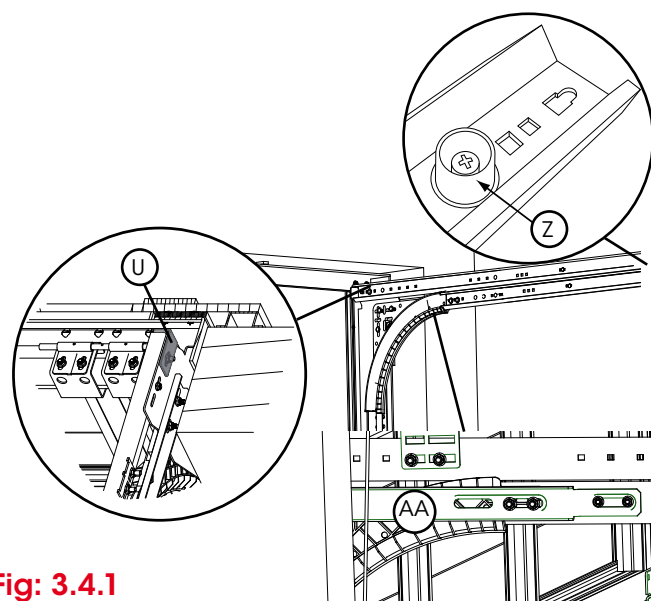

Fig: 3.4.1

WARNING! The safety stop must be installed. Failure to do so may cause serious personal injury or damage to property.

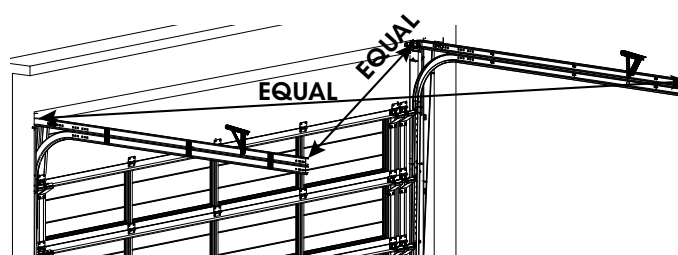

Fig: 3.4.2

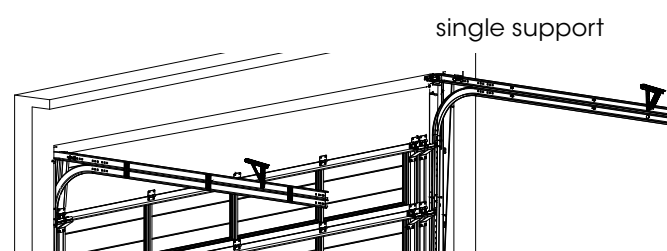

Fig: 3.4.3

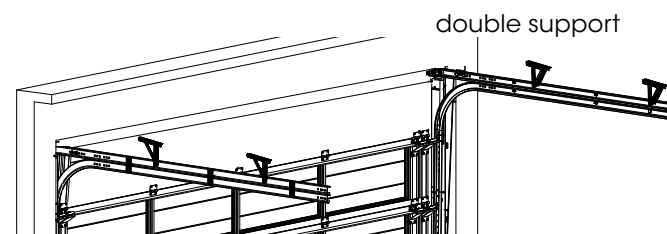

Fig: 3.4.4

3.5 installing top panel

- Place the top panel into position and clamp to hold in place.
- Insert the wheel axle (M) into the top hanger and slide down the top horizontal track to the stopper plate.
- Align wheel axle with the position of the below panel wheel axle (adjusting hanger if needed as per Fig 3.3.2). The wheel should rest lightly against the top of the horizontal track to push the door into the fully closed position. Secure top hanger to panel with nuts and bolts. Fig 3.5.1.



Use an extended impact drive 152mm & 3/8 socket to secure the hanger (R) in place.

- Repeat for the other side of top panel.
- Ensure there is a 10-12mm gap with a 22.5 degree angle cut between the cladding on the door and the cladding above in order to allow the top panel to run freely. (Fig 3.5.2)

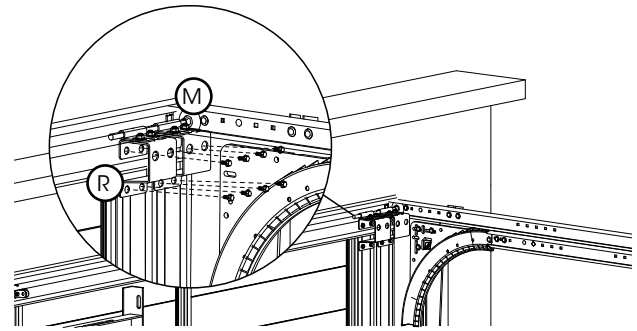

Fig: 3.5.1

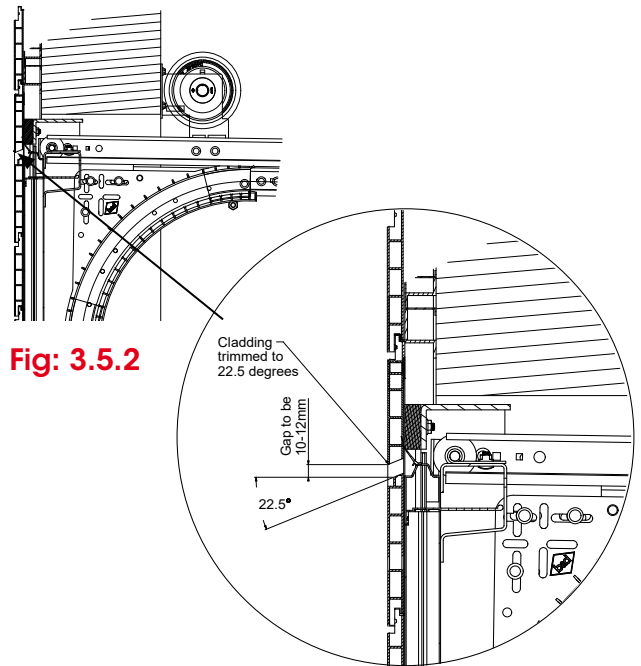

Fig: 3.5.2

3.6 spring counterbalance system

! tip If an opener is being fitted, consider where the C-Rail wall bracket is to be placed before fixing the spring anchor bracket (K)

The springs and drums for the counterbalance system are now colour coded to easily identify which side of the centre bracket the spring is placed. Fig. 3.6.1.

- a) Place the torsion bar (C) on the floor and slide the spring anchor bracket (K) onto the torsion bar, positioning it approximately half way along.
- b) Locate the cable drum/s (J), washers (S), side bearing brackets (L), spring/s (I) and shaft collar (W) and assemble them as shown in Fig. 3.6.1.

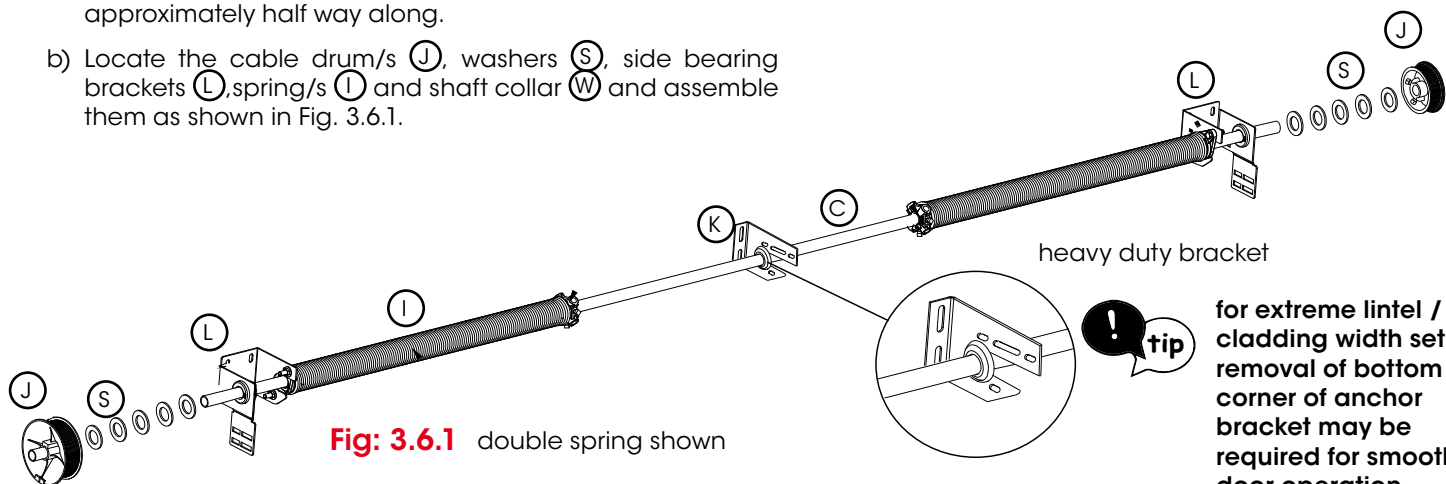

- c) Ensure the shaft collar is butted up against the anchor bracket as shown in Fig. 3.6.1 and fixed to axle on spring side of anchor bracket.

! CAUTION: DO NOT tighten bolts in cable drums yet

- a) Lift the torsion bar assembly into position, resting both ends over the top of the horizontal tracks. Fig. 3.6.2.
- b) Ensure that the side bearing brackets (L) and cable drums (J) are situated on the outside of the horizontal tracks.
- c) Line up the spring anchor bracket (K) with the middle of the door, so that the cut corner is facing down.
- d) Slide the torsion bar assembly towards the wall so the spring anchor bracket can touch the wall (the axle must be parallel with the opening).

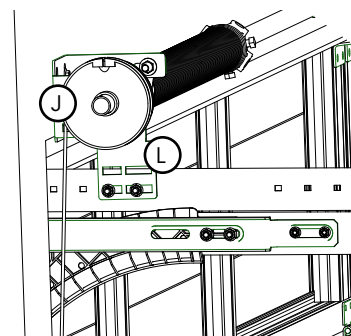

Fig: 3.6.2

! tip It may be necessary to offset the anchor bracket in order to clear room for the opener C-rail.

- e) Secure the spring anchor bracket to the wall and the side bearing brackets to the tracks as shown in Fig 3.6.2.

! tip Unwind the lifting cable from the bottom panel.

- f) Attach the lifting cable to the cable drum by slipping the cable into the slot on the outside groove. (the ferrule will prevent the cable from coming out).
- g) Wind the cable by hand by turning the cable drum away from the door.
- h) Once the cable is taut, slide the cable drum against the side bearing bracket and tighten the screws to the torsion bar. Fig 3.6.3.

! tip There must be no more than ONE turn of cable around the cable drum. Too much cable will affect the spring tension.

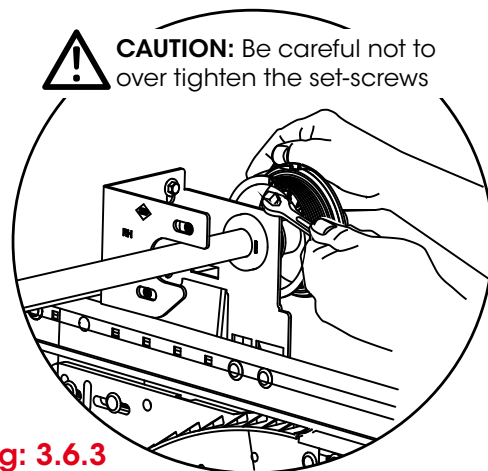

Fig: 3.6.3

3.7 adding tension to spring

WARNING! Torsion springs can cause serious injury. DO NOT underestimate the tension in the spring.

WARNING! Keep hands clear of the spring and the spring winding plug at all times.

The number of turns required for each spring is shown on a paper tag attached to the springs. Fig 3.7.1

a) Secure the torsion bar using 2 pipe wrenches, as shown in Fig 3.7.2.

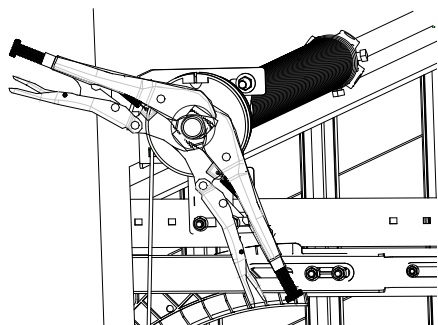

Fig: 3.7.2

tip Doors with total weight over 200kg require 850mm* long winding bars. These can be purchased from B&D (p/n OT05480-1).

b) Turn the spring by inserting winding bars into the plug holes of the spring and wind up in the direction towards the opening. Fig 3.7.3.

WARNING! Always have one winding bar engaged and firmly held while turning and tightening screws.

c) Once you have completed the turns required, remove one winding bar. If spring snaking occurs, tap the remaining bar back towards the spring anchor bracket.

d) Maintain firm tension on the winding bar, while using a spanner to tighten the two (2) grub screws. Fig 3.7.4.

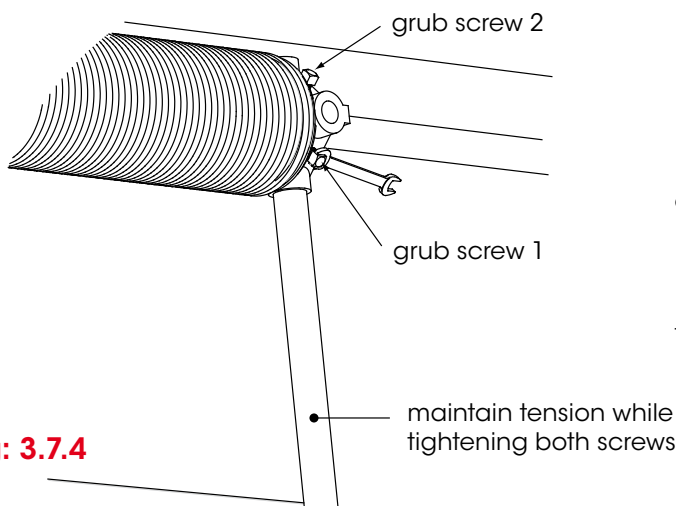

Fig: 3.7.4

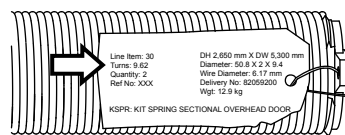

Fig: 3.7.1



The label lists how many full turns. Alternatively, a line is painted along every spring. If the spring is turned 8 times, 8 lines can be seen along the spring

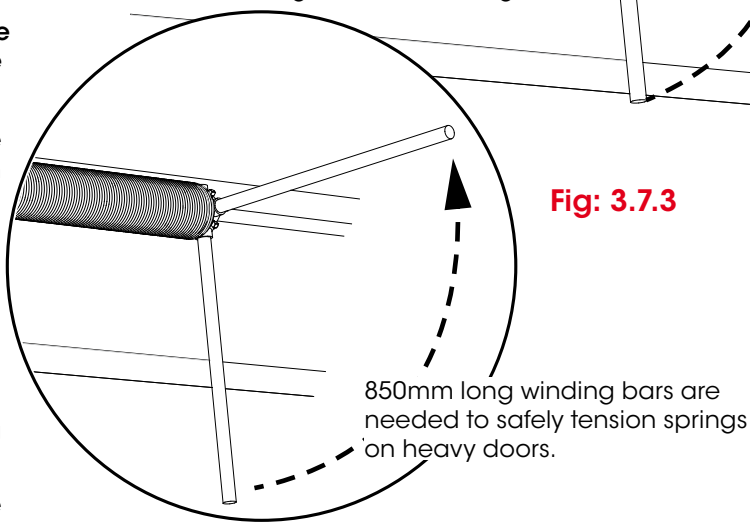
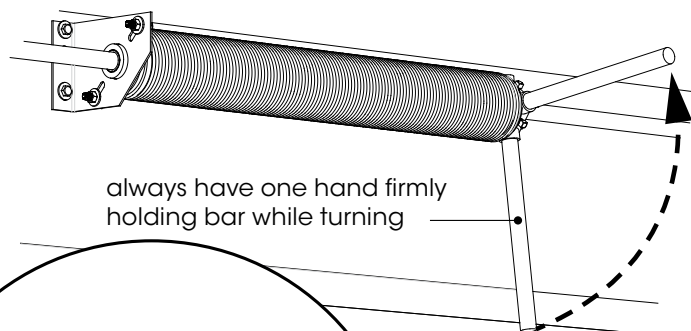
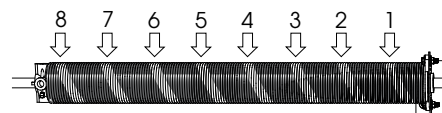

Fig: 3.7.3



CAUTION: Be careful not to over tighten the grub screws. DO NOT tighten with rattle guns. Ensure max torque on each grub screw DOES NOT exceed 25Nm.

- e) Repeat this procedure if there is more than one spring, remembering to always wind the spring, whether left or right hand, in an up direction towards the opening.
- f) Check that all screws are properly tightened before removing the wrenches on the torsion bar.



3.8 final checks

For optimal performance the door needs to operate efficiently.

- a) Manually move the door up and down, the door should move freely without binding or sticking.
- b) The maximum force required to move the door should not exceed 20kg.
- c) Lift the door to about halfway. When released, the door should stay in place. Fig 3.8.1.
- d) Check that the clearances in the vertical tracks as per Fig 3.1.2 is also in the horizontal tracks.
- e) If you find that the door is binding, open out the horizontal tracks slightly to create the correct tolerance.
- f) Once satisfied that the operation of the door is as near perfect as possible, check that all nuts and bolts are tight.
- g) Oil the springs full length to prevent noise and reduce friction. TAL 5 or similar oil rich lubricant in a pressure spray can is acceptable. Fig 3.8.2

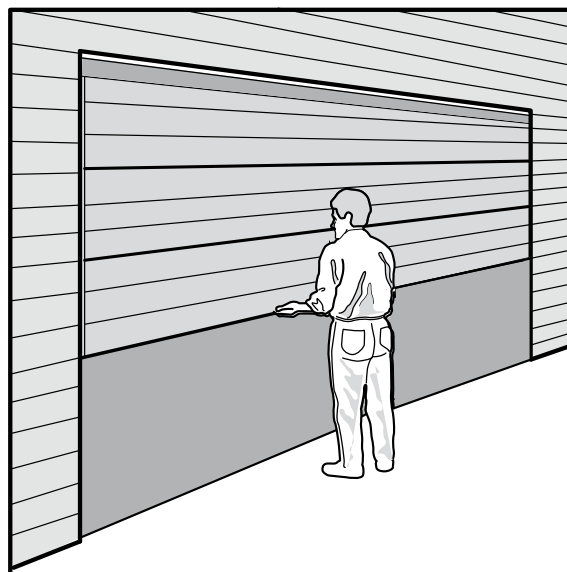

Fig: 3.8.1

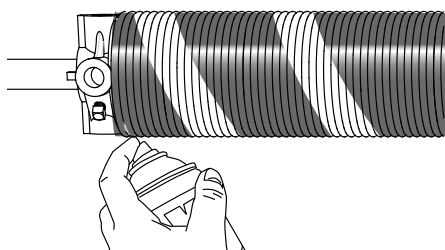

Fig: 3.8.2

WARNING! The safety handle must always be fitted to the door

Finally, the safety handle must always be fitted to the door.

- a) Fit a "D" handle using screws to the middle of the bottom panel.
- b) Remove the temporary cladding ③ & boards ④ from front of door. Fig 3.8.3.
- c) Remove any plastic film from the panels.

CAUTION: Ensure the warning label is placed on the back of the door in a clearly visible position.

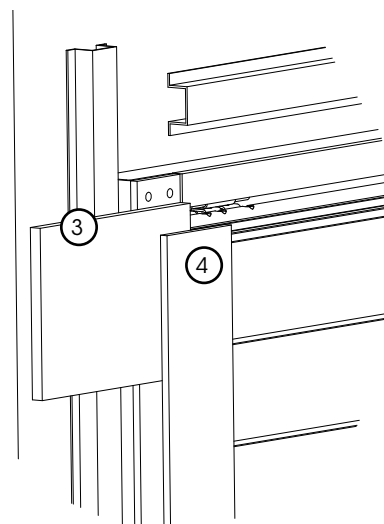

Fig: 3.8.3



4.0 troubleshooting

Symptom	Possible cause	Remedy
lifting cables loose when door is opened	cable drums have slipped diagonals out of square lifting cables not wound till taut	check the screws on the cable drums check the horizontal tracks are square loosen screws on cable drums and wind cables till taut, then tighten screws.
torsion bar moving	cable drums not adjusted correctly springs not adjusted correctly shaft collar not fitted (single spring) end bearing brackets are not straight	check and adjust check spring tension fit shaft collar, see section 3.6. check end bearing brackets are square and vertical
door will not hold up in open position	spring tension not tight enough incorrect placement of springs	check the correct number of turns has been made to spring/s. refer to section 3.7. check the springs are on the correct side/s, refer to section 3.6.
door not level	water level marks incorrect lifting cable not equally taut	check the water level marks are correct loosen screws on cable drums and wind cables till taut, then tighten screws.
door moving to one side	clearances incorrect cable drums not close to end bearing brackets	check the clearance/overlap of the door is equal on each side. loosen screws on cable drums and ensure they are hard up against the end bearing bracket and tighten screws.
door panels jamming / rubbing on tracks	incorrect clearance between wheel and vertical track door not level cable drum not lined up correctly vertical tracks not parallel lifting cables slipping	Check that the clearances per Fig 3.1.1 are the same in both vertical and horizontal tracks. check water level marks are correct. loosen screws on cable drums and ensure they are hard up against the end bearing bracket and tighten screws. Check that the clearances per Fig 3.1.1 are the same on both vertical tracks. loosen screws on cable drums and wind cables till taut, then tighten screws.
door hard to lift	spring tension spring may have slipped on set screws wrong spring	check the correct number of turns has been made to spring/s. refer to section 3.7. Ensure springs have been lubricated. check spring plug grub screws are tight, refer to section 3.7. check the springs are on the correct side/s, refer to section 3.6.

common spring problems

symptom	possible cause	rememdy
door raises from the floor and hangs down in opening more than 100mm.	cable length too long with cable not on high portion of drum	shorten cable length until the cable rolls onto the flat portion of the drum when the door starts into the horizontal position
	springs may be too strong (too short)	replace spring
	wrong cable drums for springs (too small)	replace cable drums
door lifts from the floor and runs away at the top	door is over tensioned, too many turns on spring or wrong spring	ensure that the correct spring is supplied (if not replace) and that it has the correct number of turns applied
	wrong cable drums for spring, (too small)	replace cable drums
door falls to the floor and hangs down in the opening	door is under tensioned too few turns on spring or wrong springs	ensure that the correct spring is supplied (if not replace) and that it has the correct number of turns have been applied
	wrong cable drums for springs (too large)	replace cable drums
door falls to the floor and runs away at the top	lifting cable may be too short for high lift cable drum or vertical lift drum and is sitting too high on the spiral portion of the drum	increase the cable length to bring the cable down lower on the spiral
	torsion springs too long	shorten springs
door balances at the floor but runs up or down in between	cables in wrong position on spiral of the drums	adjust cable length
poor balance throughout	winding spring in wrong direction	wind in correct direction
	door weight incorrect	supply correct springs
	springs binding	fit torsion bar collar lubricate springs
	door not level	cable lengths are equal equal turns on both springs level door during installation

5.0 appendix

5.1 after installation care

cleaning

Your B&D Designer Series panels are made from aluminium extrusions and are hence resistant to corrosion, however in our atmosphere there are harmful deposits that gather on the door surface and if not removed regularly, will seriously affect the appearance. Touch up paint is available for blemishes in the paintwork where damage has been done in powder coated doors.

hinges

If the hinges and hangers squeak and squeal during operation then the hinges haven't been greased or the grease has dried up. Please apply some grease into the holes in the hangers and hinges as pointed out in the diagram below.

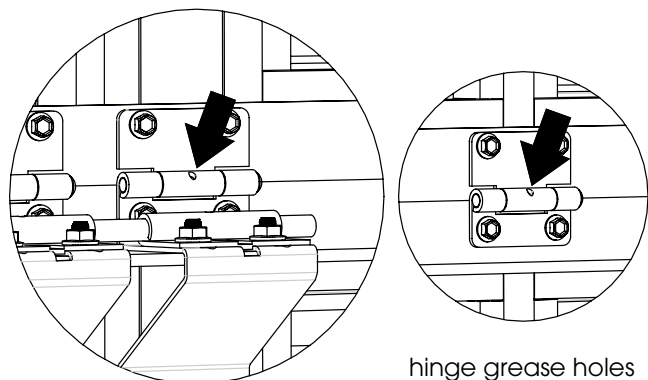

regular maintenance required

B&D recommends that you check the operation of your Designer Series at least every six months (more regularly in extreme environments or frequent use). The effort required to manually open and to manually close the door should be about the same (if door has an automatic opener, put into manual mode before testing door). If the door is difficult to operate in either direction (up or down) then check that the inside surfaces of the guides are clean and free of obstructions.

If the door is still difficult to operate, then your door will need a service to adjust the spring tension and possibly other operational parts of the door. This service should only be carried out by an experienced door technician, using the correct tools.

If you have an automatic opener fitted to your door, it is particularly important that you ensure the optimum operation of the door, otherwise you may reduce the effective life of the opener.

To keep your door running well, it is recommended that your door be serviced, by an experienced door technician, every 12 months (more regularly in extreme environments or frequent use), or earlier if required.

spring tension

It is natural for springs to lose tension over time. When spring tension is adjusted or when your door is first installed it is usual to apply a little more tension than is required for balanced operation, to allow for the normal

"settling in" of the springs. Lightly lubricate to prevent friction between the coils.

warranty

Warranty conditional on proper care as recommended above. Full details of the warranty are available in your owners handbook, from your nearest B&D office or visit the B&D website www.bnd.com.au

b&d doors office locations

Head Office	6-8 Fiveways Blvd, Keysborough 3073	Phone (03) 9791 2000
New South Wales	34 Marigold St, Revesby 2212	Phone (02) 9722 5555
Queensland	17 Oasis Court, Clontarf 4019	Phone (07) 3883 0200
Victoria	147-153 Canterbury Rd, Kilsyth 3137	Phone (03) 9237 7766
South Australia	23 Frederick Rd, Royal Park 5014	Phone (08) 8440 4747
Western Australia	96 Mulgool Rd, Malaga 6090	Phone (08) 9247 8777
International/Export	34 Marigold St, Revesby 2212	Phone +61 (0)2 9722 5555

your representative is