

b&d

Tilt-A-Dor®

J-Fitting

installation instructions

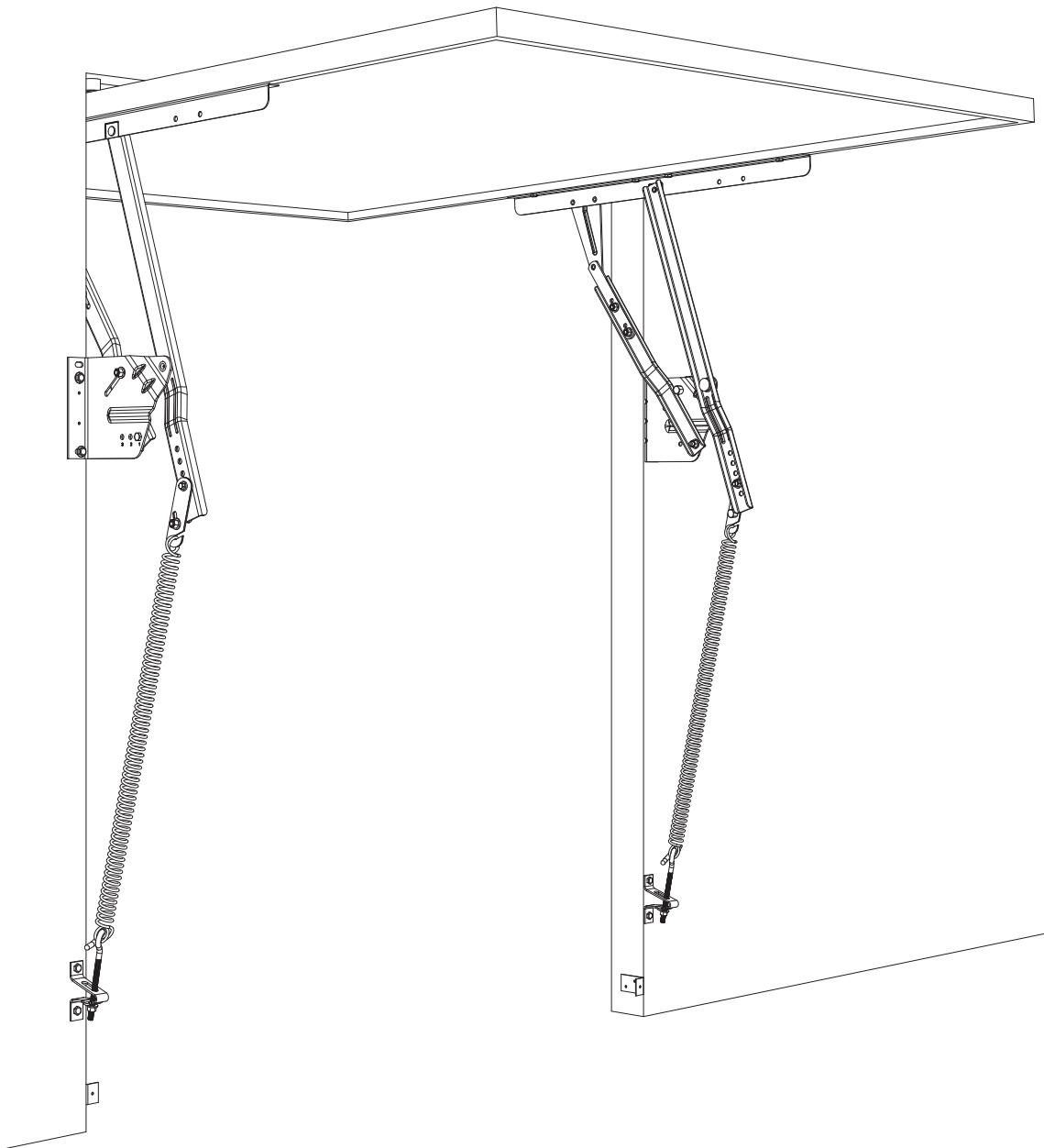

These instructions are intended for professional garage door installers. All references are taken from inside looking out.

REVISION 4 - OCTOBER 2016

www.bnd.com.au

b&d

contents

1.0	before you start	3
1.1	safety checklist	3
1.2	fastener recommendations for fitting garage doors	4
1.3	tools checklist	5
1.4	checking measurements	5
2.0	installation	6
2.1	determine pivot position	6
2.2	frame door opening	7
2.3	locating main brackets	7
2.4	install power arms	8
2.5	install door panel	8
2.6	secure power arm and door panel	9
2.7	install equaliser assembly	9
2.8	install springs	10
2.9	adjustment	10
2.10	side fix fitting	11
3.0	after installation care	13

1.0 before you start

1.1 safety checklist

The following hazards and hazard controls have been identified for installers during the installation of these fittings.

hazard	control
<ul style="list-style-type: none"> Housekeeping - risk of slip trip or fall Housekeeping - risk of injury to other people or animals in the installers work area 	<ul style="list-style-type: none"> Tidy up site prior to start work as a minimum area should be at least the area of the installation back into the garage and 2 metres in front If the Site housekeeping is deemed to be unsafe do not install the door Keep all people well clear of installers work area with appropriate signage and discussion with owner
<ul style="list-style-type: none"> Weight & awkwardness of lifting of springs and fittings Manual handling when moving the fittings from the Trailer or Ute to the installation area - risk of musculoskeletal injury Manual handling when installing Doors & Openers particularly above head height - risk of musculoskeletal injury or twisting Manual handling when installing springs, tracks and torsion bars - risk of musculoskeletal injury 	<ul style="list-style-type: none"> Utilise correct lifting techniques for springs and fittings. Use of 2 person lifts Use of mechanical aids Avoid twisting (practice correct lifting techniques) Correct use of ladders while installing tracks
<ul style="list-style-type: none"> Working at heights and working with ladders - risk of fall from height 	<ul style="list-style-type: none"> Ladder check Ladder placement Do not work off the top rung
<ul style="list-style-type: none"> Sharp edges on tracks or related jewellery - risk of laceration 	<ul style="list-style-type: none"> Wear appropriate PPE (Dyneema cut off gloves)
<ul style="list-style-type: none"> Pinch points - risk of cut, puncture or crush injury Scissor action of fittings - risk of laceration 	<ul style="list-style-type: none"> Wear appropriate PPE and keep hands well clear of pinch points Ensure hands well clear of the panels Follow instruction explicitly particularly for the installation as the scissor action of some fittings presents a very sharp edge
<ul style="list-style-type: none"> Use of hand tools - risk of eye injury, laceration cut stab or puncture injuries (tools checklist) Use of Electric/ Battery or pneumatic tools - noise hazard Use of cutting tools creating sparks - risk of fire 	<ul style="list-style-type: none"> Wear appropriate PPE and utilise operators manual Use appropriate noise/hearing protection in the form of ear plugs or ear muffs Ensure appropriate fire protection available and housekeeping to ensure that flammable liquids or materials are removed from the area of work
<ul style="list-style-type: none"> Spring release of energy - risk of release of stored energy (striking installer on the head or body) 	<ul style="list-style-type: none"> As the spring is at it greatest tension during the time the door is being opened or closed - correct fixings and correct fittings MUST be used during every installation. Including the number of bolts to be used, the equaliser plate, pigtailed bolt and spring anchor bracket. These have been specifically designed to ensure that the spring is held in place at all times. The correct sized door MUST be used for the recommended springs The owner MUST be informed of maintenance requirements

1.2 fastener recommendations for fitting garage doors

material	fastener type(s)	diameter or type		length of fastener (see note)
New Solid Brick	Coach Bolts (Hex Lag Screw) - combined with wall plugs	5/16"	x	1½"
		3/8"	x	2"
	Macplugs (wall plugs) to suit above	5/16"	x	50mm
		3/8"	x	60mm
	HLC Sleeve Anchors (Dyna Bolts)	12mm	x	55mm
New Hollow Brick	HRD-VGK or HGK-VGS (Hex Head) Frame Anchors	10mm	x	60mm
New Solid Concrete	Coach Bolts (Hex Lag Screw) - combined with wall plugs	5/16"	x	1½"
		3/8"	x	2"
	Macplugs (wall plugs) to suit above	5/16"	x	50mm
		3/8"	x	60mm
	HLC Sleeve Anchors (Dyna Bolts)	12mm	x	55mm
Aerated Concrete e.g. (HEBEL)	Fischer Nylon Twist Lock Anchor Type GB 14	14mm	x	85mm
Steel Framing e.g. BHP Framing (with rear access)	Hex Head Bolt Zinc Plated, Hexagon Nuts Zinc Plated, Washers Zinc Plated	5/16"	x	1"
		3/8"	x	1"
		10mm	x	25mm
		12mm	x	25mm
Heavy Gauge Steel	Hex Head Tek	14-20	x	22mm
Light Steel Framing e.g. BHP House Framing (no rear access)	Heavy Duty Kap Toggle	10mm	x	100mm
		12mm	x	100mm
	Hex Head Tek	6-10	x	20mm
New Timber	Coach Bolts (Hex Lag Screw)	5/16"	x	1½"
		3/8"	x	2"
	Hex Head Tek	14-10	x	50mm

important notes

- For installation to materials not covered in the above chart, the installer should seek expert advice from a qualified builder.
- Minimum length of fastener does not exclude use of longer lengths. Decision must be made by fitter to ensure adequate strength.
- Recommendations for old materials or materials not in good condition are not included. If in doubt about the strength of the material seek specialist advice.
- Fasteners for sectional door spring brackets and top track brackets in masonry should be at least 5/16" x 2.5" long or metric equivalent.
- HEBEL Fischer type fastener should be installed 150mm from edge of blocks. Minimum overlap of door should be approximately 115mm (S1), 110mm (S3) and 90mm (Panelift). Add 50mm more if mounted on panels instead of blocks.

important information on fasteners

Coach bolts/screws supplied with this product are suitable for fastening to timber jambs. Correct and safe fastening to other materials may require different fasteners. The installer must select and use fasteners appropriate to the material into which they are being fixed.

1.3 tools checklist

The following tools are needed to install Tilt-A-Dor® J-Fitting.

- Spirit level 1200mm
- Measuring tape
- Extension lead
- Step ladder
- Speed drill and drill bits
- Impact drill and masonry bits
- Hack saw
- Open end adjustable spanner
- Socket set
- Set square
- Wood chisel
- Steel chisel
- Screw driver set
- Pliers
- Tin snips
- 2 vice grips
- Felt tip pen & pencil

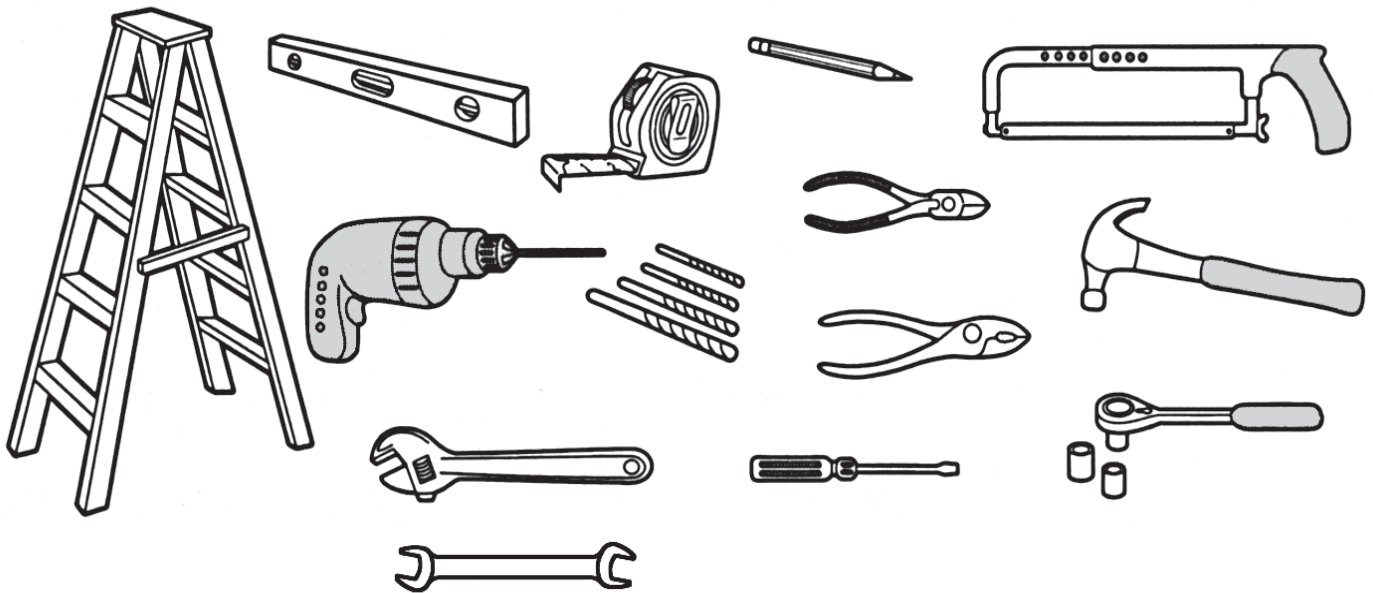

1.4 checking measurements

Before proceeding please check the opening measurements against the panel and ensure that the correct fitting has been obtained in regards to door weight.

Door Width	Opening Width - 24mm
Door Height	Opening Height - 24mm
Min. Headroom	50mm for a manually operated door 100mm with an automatic opener
Min. Sideroom	50mm
Max. Door Height	2250mm
Min. Door Height	1850mm

If making jamb out of timber, we suggest using Oregon structural timber, minimum width 50mm.

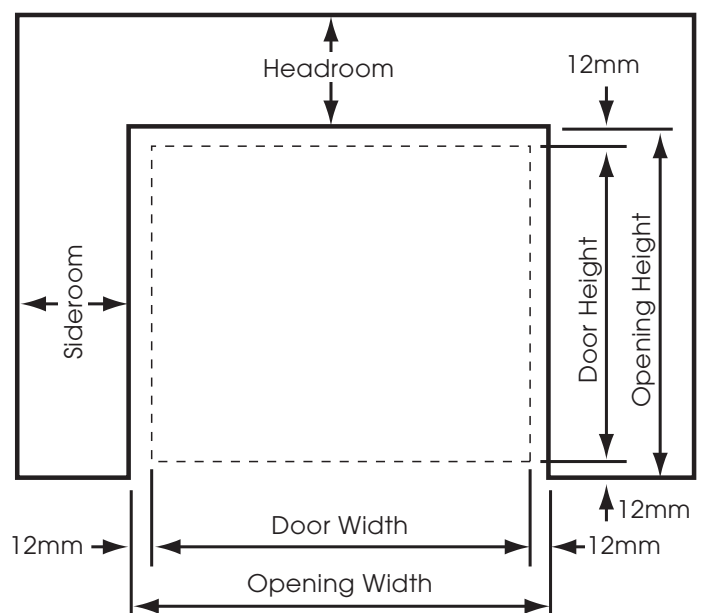

2.0 installation

2.1 determine pivot position

Determine overhead clearance above and behind door opening.

The curves in Figure 2.1.1 were plotted with inside of door flush with inside of jamb. For smooth operation pivot position No. 1 is preferred but if headroom is restricted use pivot positions No. 2 or No. 3 if required.

If 140mm or more headroom is available use pivot position No. 1.

If 60mm headroom is available use pivot position No.2.

If 25mm headroom is available use pivot position No. 3.

Model J equipment is entirely supported by the door jambs.

If door is to be fitted with an automatic door opener, use pivot position No. 1.

If insufficient headroom is available contact an Approved B&D Door Dealer.

Figure 2.1.1 Distances Door Travels (mm)

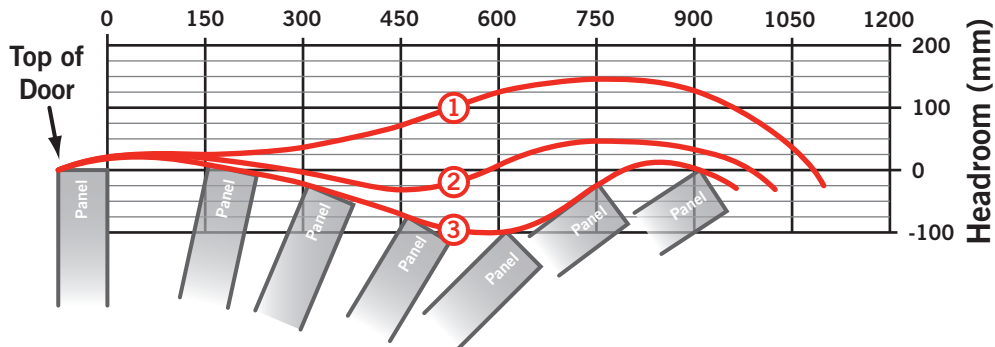
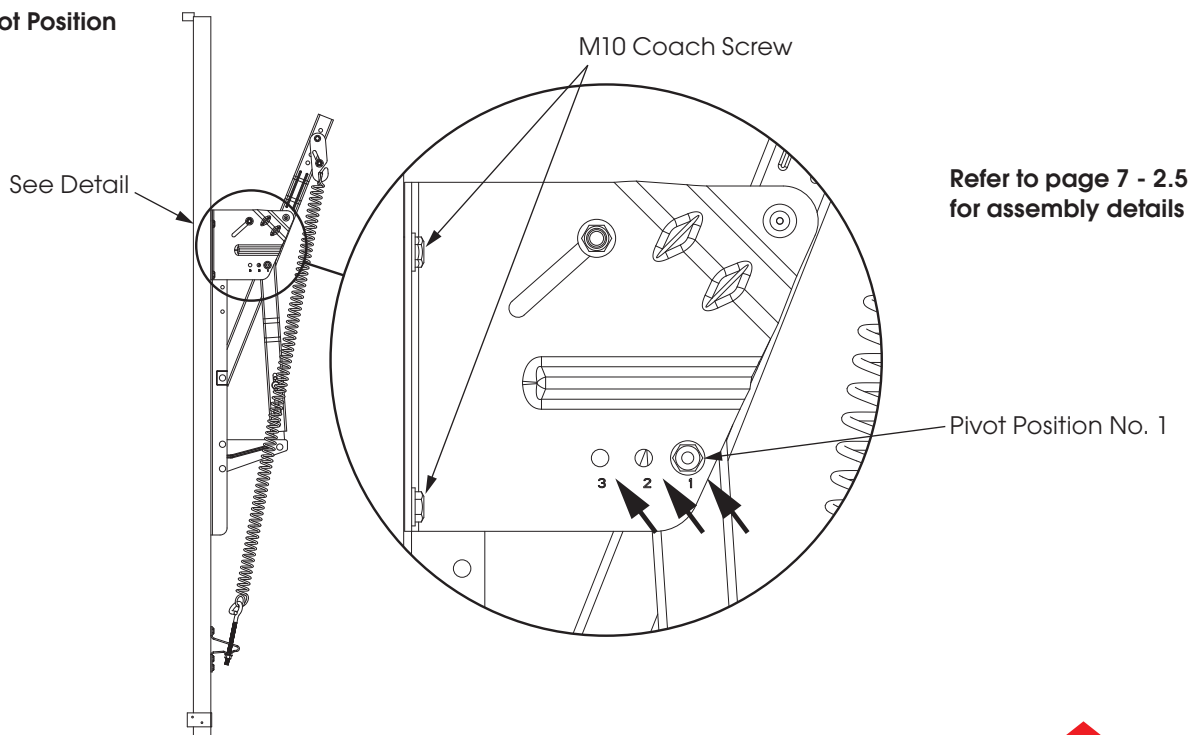

Figure 2.1.2 Pivot Position



2.2 frame door opening

It is essential that door jambs be SECURELY FIXED. Use a stable softwood timber (100mm x 50mm minimum).

If securing timber jambs to brickwork leave heads of bolts flush or below face of jamb.

“Lap header” installation is always preferred to “under the header” installation as it provides desirable weathersealing features.

“Under the header” installation should be used in situations of absolute minimum headroom.

Both types of installation operate equally as well.

LAP HEADER INSTALLATION

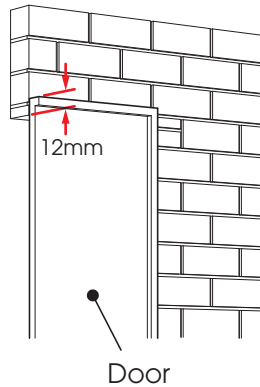

Manufacture door to allow 12mm head overlap and 12mm space at bottom of door.

UNDER THE HEADER INSTALLATION

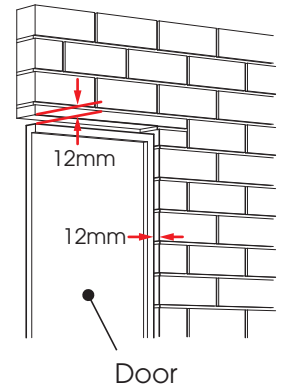

Manufacture door 24mm shorter than door opening height. (Allow 12mm head overlap and 12mm space at bottom of door.)

2.3 locating main brackets

The location of the main bracket is determined by the pivot position used.

Mark the position of the top of the main bracket at a distance down from the underside of the head, equal to the actual door thickness plus dimension “D” given in the table below.

pivot position	dimension “D”
1	510mm
2	480mm
3	435mm

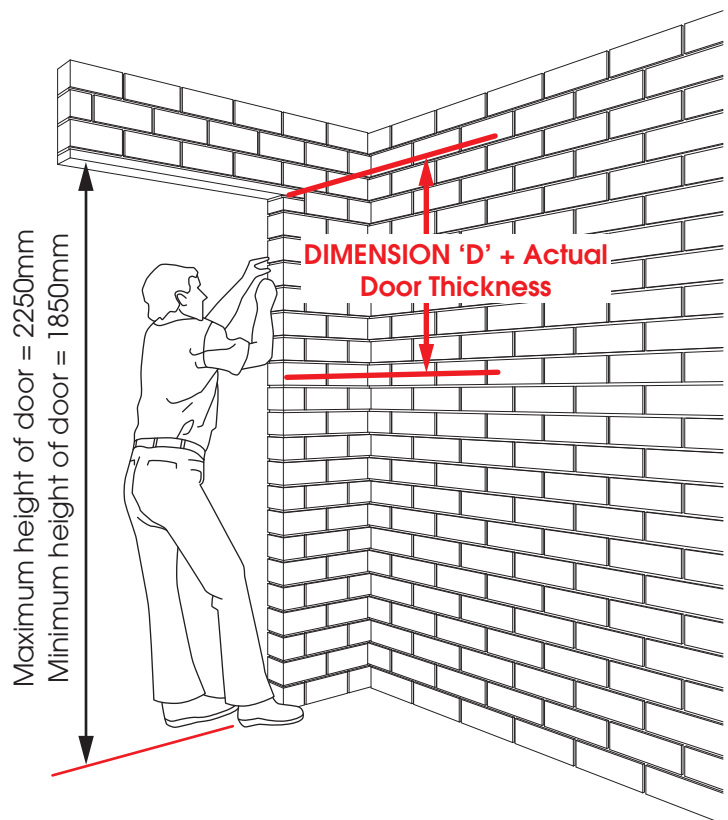

2.4 install power arms

Secure main bracket flush to door jamb with two coach screws supplied, through the flange of the bracket.

The appropriate pilot holes should be drilled in timber jambs.

M8 coach screws: $\varnothing 5.5\text{mm}$
M10 coach screws: $\varnothing 7\text{mm}$

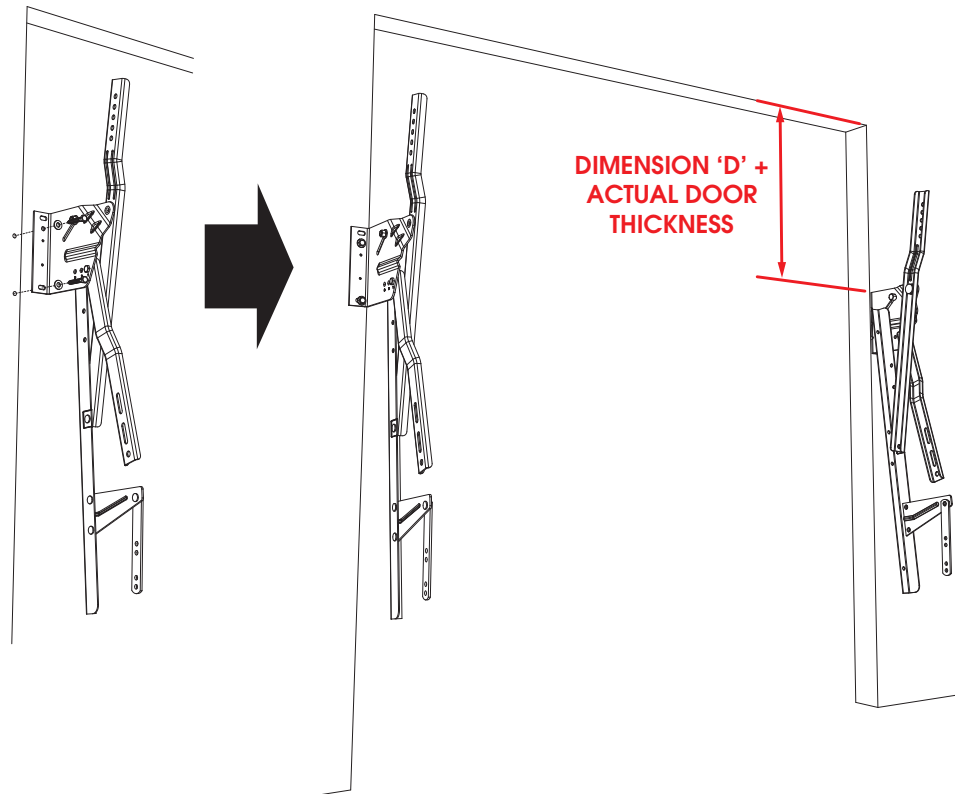

2.5 install door panel

Place door in opening and elevate with 12mm shims. Swing power arms towards door. A clearance of 12mm should be allowed between door jamb and edge of door.

Attach loose cantilever arms and secure with M10 x 20 carriage bolts.

Position the angle arm 10mm from the edge of the panel to prevent cantilever arm rubbing on the main jamb bracket.

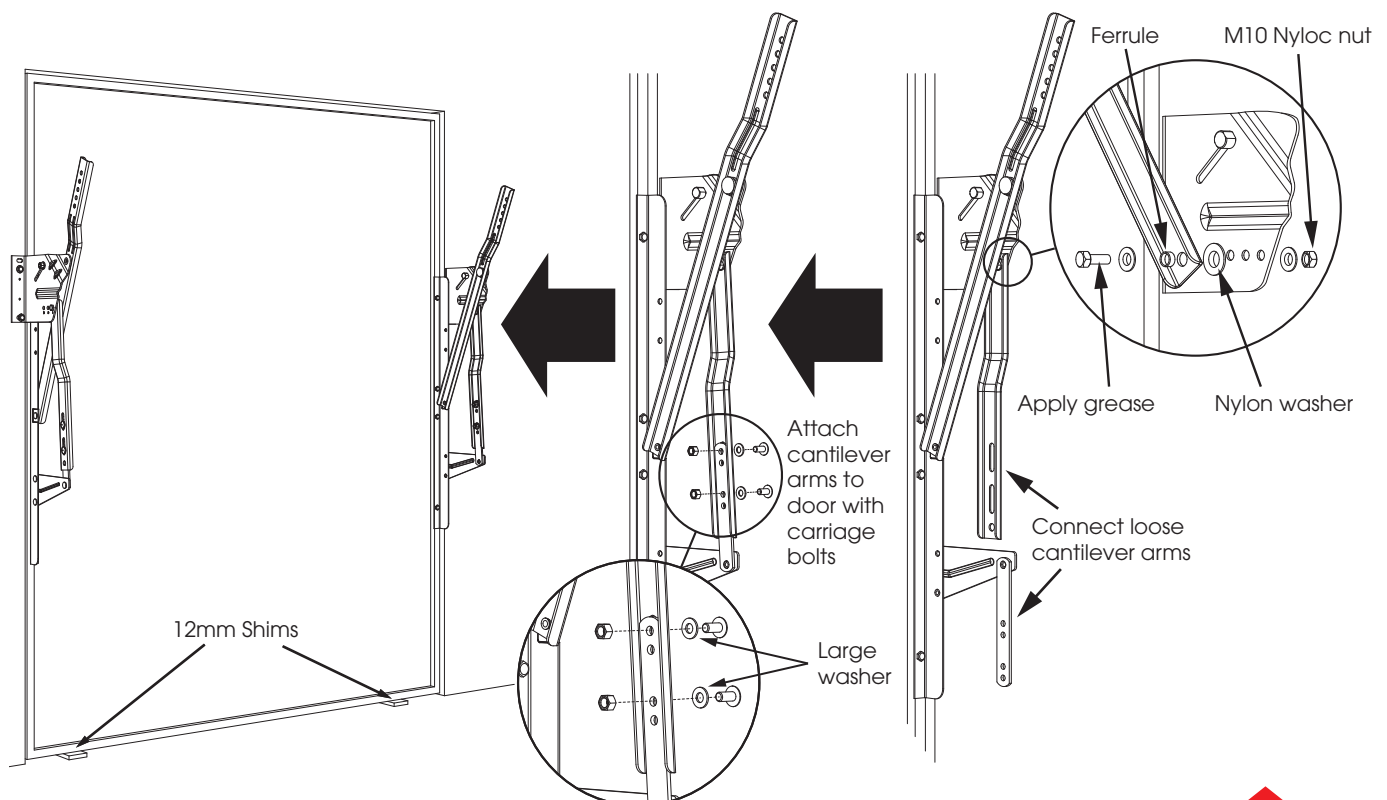

2.6 secure power arm and door panel

Raise door and firmly prop in open position. If main brackets are correctly installed door should have slight fall to front when in "open" position.

Install striker plates approximately 200mm from bottom of door jamb.

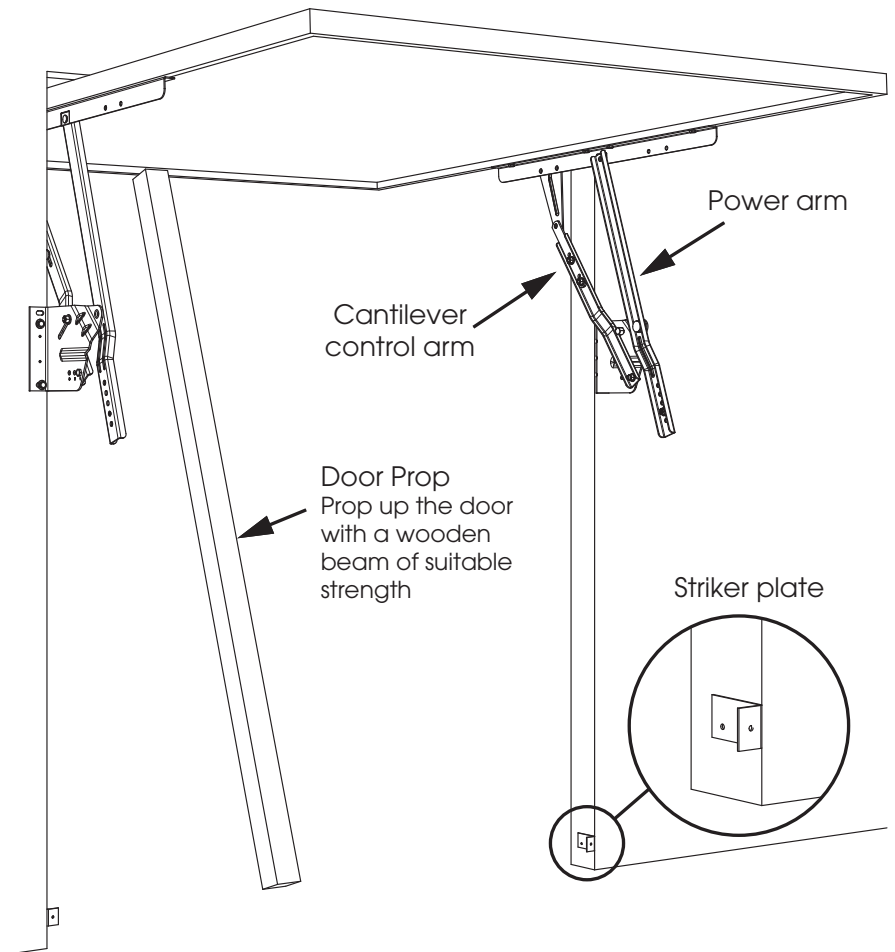

2.7 install equaliser assembly

Fix equaliser assembly to power arm with pivot bolt.

Determine correct hole by experimentation after the door is completely installed. Start by trying the second hole from the end of the power arm.

The anti-slam attachment works on both left or right hand sides. Position the anti-slam bolt face the door as shown in the diagram.

Ensure that the nut on the pivot bolt securing the equaliser assembly to the power arm is as tight as possible.

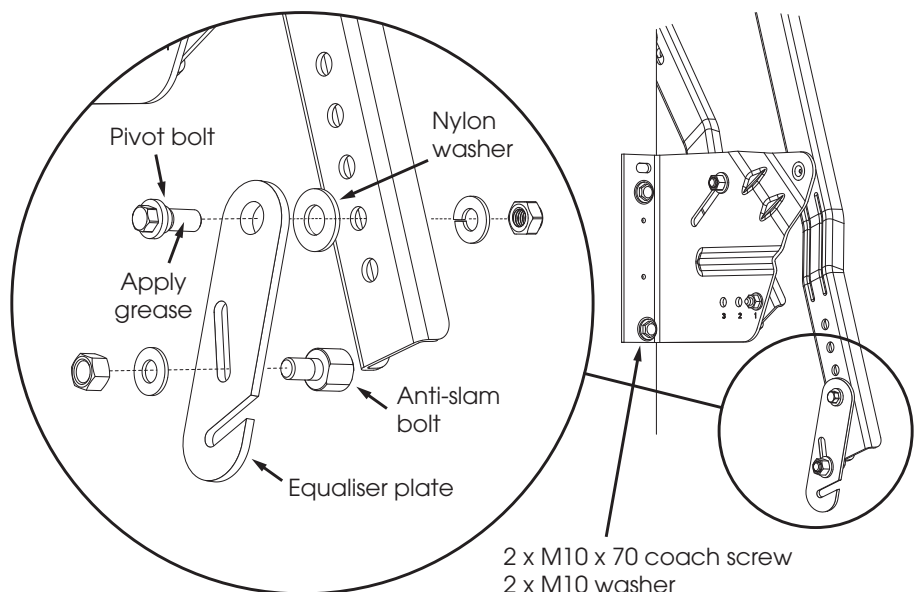

2.8 install springs

Hook spring on equaliser plate as shown in A. Then insert pigtail bolt into the bottom spring loop then pull down through spring anchor bracket and secure with nut and washer as shown in B. To apply tension screw nut up the thread of the pigtail bolt.

Position of spring anchor bracket so the spring is stretched by at least 75mm in the door open position.

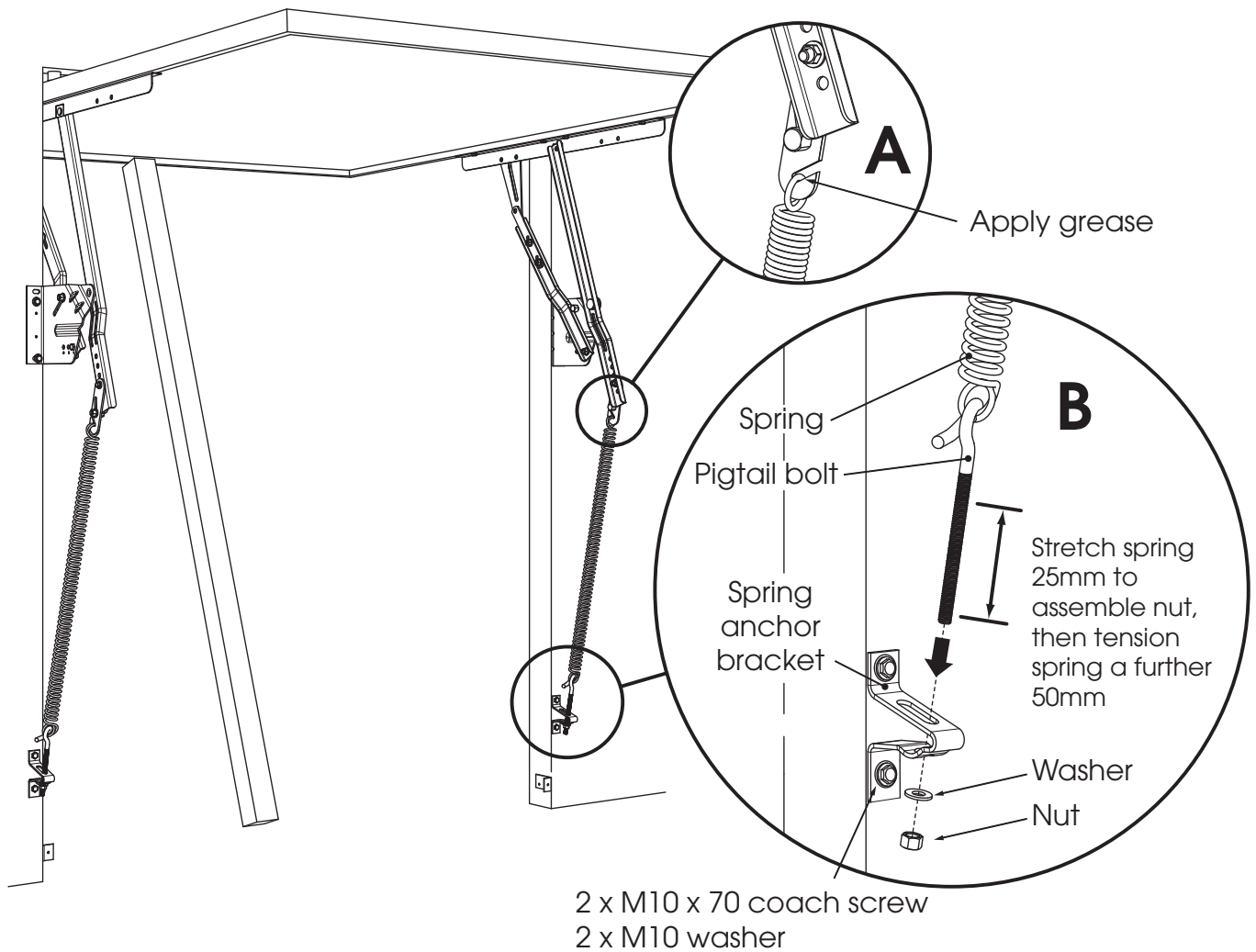

2.9 adjustment

Experiment to find the correct hole in power arm for equaliser assembly.

If the door is difficult to pull down move the power equaliser up a hole in the power arm (door in open position).
If the door comes down too easily move the equaliser down the power arm (door in open position).

Greater adjustment can be made by adjusting the pigtail bolt secured to the door jamb.

The anti-slam bolt in the equaliser plate controls the anti-slam action of the door in closing.

2.10 side fix fitting

To successfully install these special J-Fitting, it is essential that all brickwork be plumb, both vertically and horizontally, and that the return brickwork is square to the opening.

For position and adjustment, refer to standard installation instructions procedure discussed in previous section.

The position of the door from the front of the opening can be varied according to the depth of the opening and architectural requirements.

Move door angle flush to the edge of door to prevent cantilever arm rubbing with the main bracket.

Care must be taken to see that the fittings are fixed square to the return to avoid fouling the top part of the door when in the open position.

A minimum of three 8mm masonry anchor or equivalent is required to secure each fitting to brickwork.

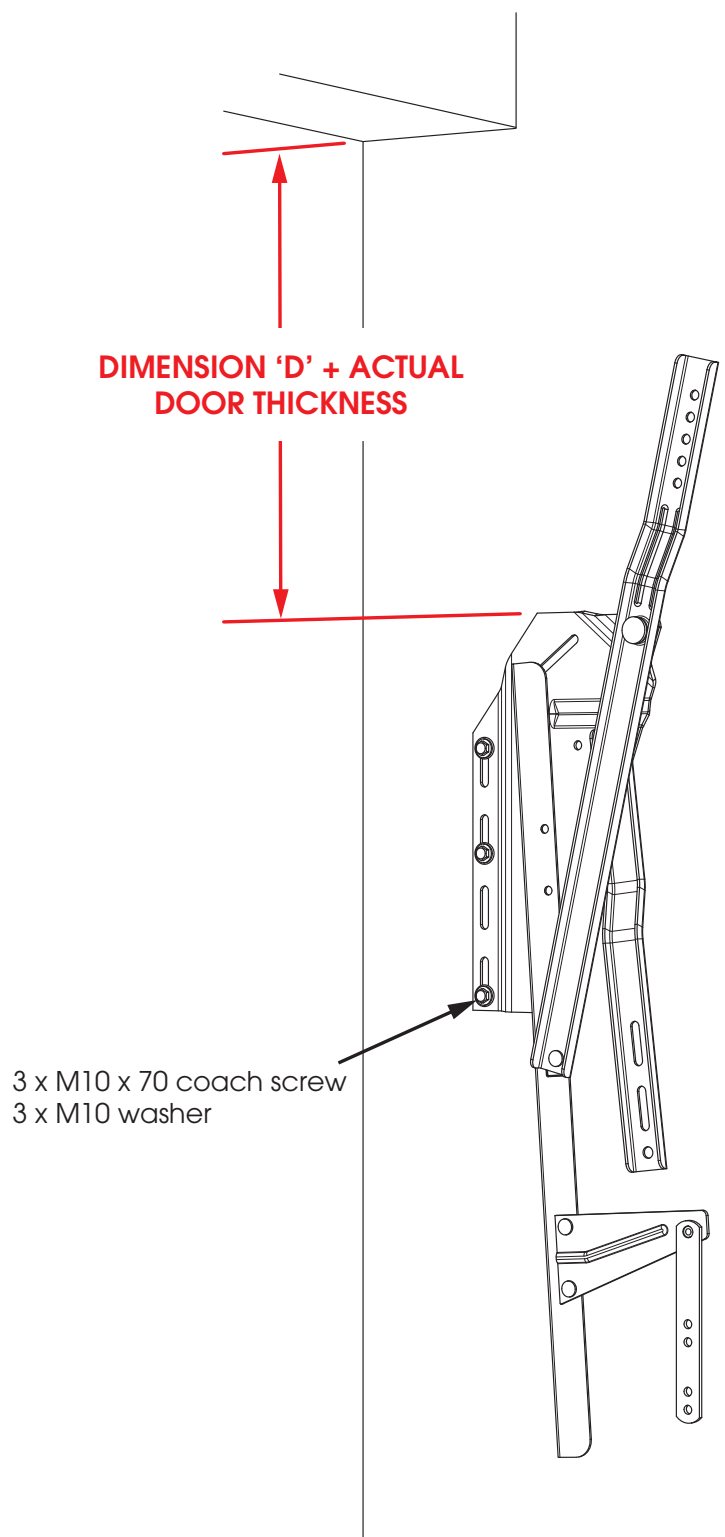

The spring anchor bracket is fixed with a single 8mm masonry anchor at the position indicated in the standard installation sheet.

Door stops to be installed at a convenient height from the bottom of the opening, or secured directly to brickwork using a suitable type of masonry plug.

The position of the door from the front of the opening can be varied according to the depth of the opening and architectural requirements.

Mounting spring anchor bracket:

- Timber fixing please use 2 x M8 x 50 coach screw and washer
- Brick fixing please use M10 Dyna bolt (not supplied)

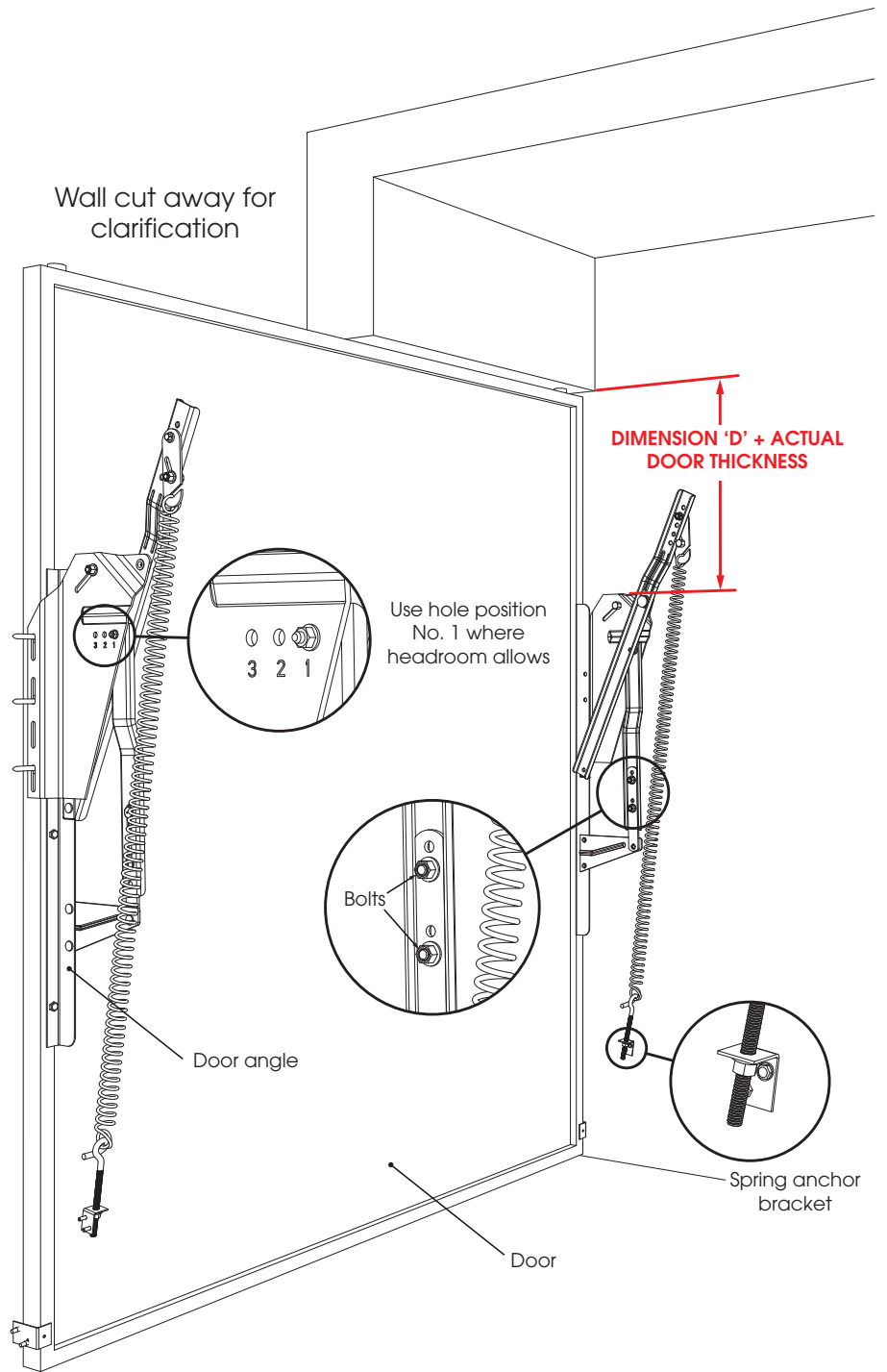

3.0 after installation care

general care of your Tilt-A-Dor® J-Fitting

regular maintenance required

NOTE: if correct maintenance and servicing are not carried out, warranty may be void.

B&D recommends that you check the operation of your fittings at least every three to six months (more regularly in extreme environments or frequent use). The effort required to manually open and manually close the door should be about the same (if door has an automatic opener, put into manual mode before testing the door).

automatic openers

If you have an automatic opener fitted to your door it is important that you ensure the optimum operation of your door, otherwise you may reduce the effective life of the opener, and void your opener warranty. For more information refer to the maintenance schedule in your opener instruction handbook.

service & repair

Fasteners: Visually check all screws, nuts and bolts, if there is anything amiss call your local B&D dealer.

Spring Tension: It is natural for springs to lose tension over time. Should the door become hard to operate or completely inoperable, contact your local B&D office, or call the B&D dealer who installed your door. To keep your door running well, it is recommended that your door be serviced by an experienced technician, every 12 months or earlier if required.

WARNING!

The spring is under tension at all times and may cause serious injury if interfered with by an inexperienced person. Adjustments and repairs should be carried out by approved B&D dealers using proper tools. Nobody should ever stand directly in the path of the door in it's downward travel or walk through doorway while door is moving. Always use the door handle or pull rope to manually operate the door. If the door is automated, the pull down rope on the door must be removed.

DO NOT PLACE FINGERS, HEAD OR LIMBS NEAR ANY MOVING PARTS OF MECHANISM ON EACH SIDE OF THE DOORWAY WHEN THE DOOR IS OPERATING EITHER AUTOMATICALLY OR MANUALLY.

b&d doors office locations

New South Wales	34 Marigold St, Revesby 2212	Phone (02) 9722 5555
Queensland	17 Oasis Court, Clontarf 4019	Phone (07) 3883 0200
Newcastle	Unit 1/108 Mitchell Rd, Cardiff 2285	Phone (02) 4956 8533
Victoria	147-153 Canterbury Rd, Kilsyth 3137	Phone (03) 9237 7766
South Australia	23 Frederick Rd, Royal Park 5014	Phone (08) 8440 4747
Western Australia	96 Mulgul Rd, Malaga 6090	Phone (08) 9247 8777
International/Export	34 Marigold St, Revesby 2212	Phone +61 (0)2 9722 5555

your representative is

Prefixed trademarks are the property of B&D Australia Pty Ltd. B&D Doors & Openers is a division of B&D Australia Pty Ltd. ABN 25 010 473 971. © 2016 B&D Australia Pty Ltd.

www.bnd.com.au

b&d